

ASSEMBLY INSTRUCTIONS

MOD-7050

V0.07.11.22

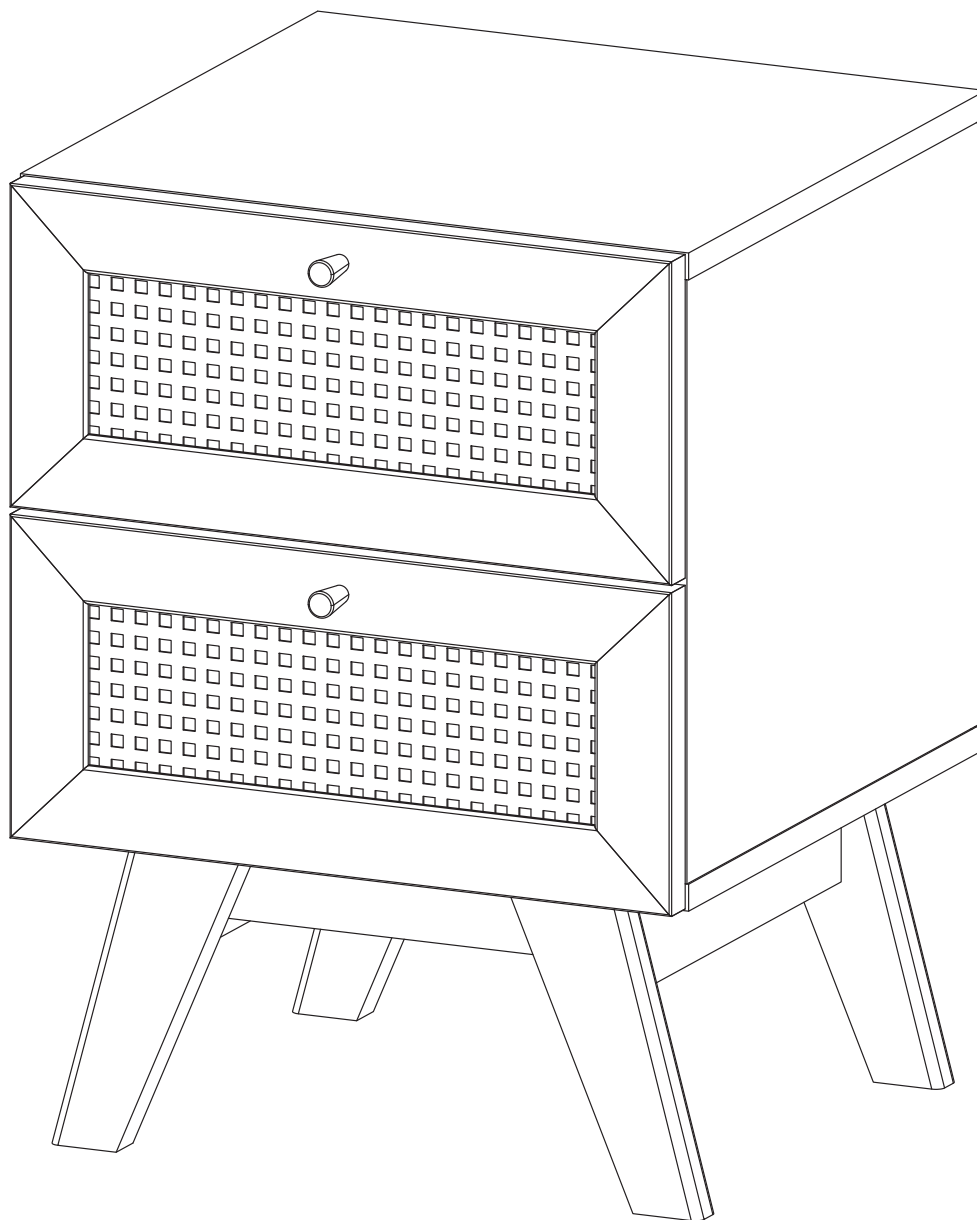

Questions? Contact us!

609.256.9000 • cs@modway.com
www.modway.com

*modway

Let's get started!

*modway



Read through all of the instructions before starting



Care instructions are listed in the last step of this manual



Approx. 45 minutes assembly time



Make sure you have all parts and components before discarding any packing materials



1 people recommended for assembly

Only use hand tools to assemble this item. Do not use power tools. Do not tighten bolts or screws completely until all hardware is lined up and inserted into the holes.

Do not over-tighten screws and bolts to avoid stripping the hardware or cracking the item.

Assemble your item on a flat, carpeted area, with plenty of space to work. This will prevent damage and scratches to your floors or the item while you're assembling the product.

Keep all components and packaging out of reach of children or animals to avoid risk of choking or suffocation.

Furniture components:

1	Top Board	x1	11	Side Drawer Left	x2
2	Bottom Board	x1	12	Side Drawer Right	x2
3	Side Board Left	x1	13	Back Drawer	x2
4	Side Board Right	x1	14	Bottom Drawer	x2
5	Back Board	x1			
6	Bottom Skirt 1	x2			
7	Bottom Skirt 2	x2			
8	Leg 1	x2			
9	Leg 2	x2			
10	Front Drawer	x2			

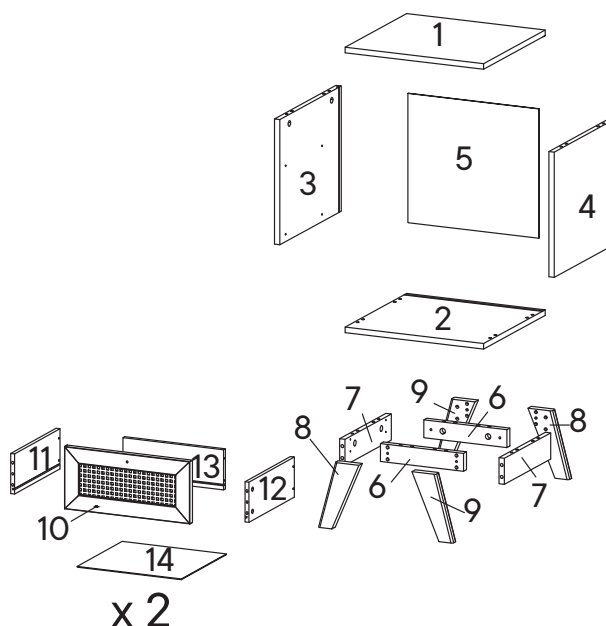

Provided hardware:

A		Cam Bolt Ø6 x 35 mm	x20	J		Screw M 3.5 x 15.5 mm	x12	RM30A		Drawer Runner	x2
B		Cam Lock Ø15 mm	x12	K		Floor Protector	x4	What you need:			
C		Wood Dowel Ø8 x 30 mm	x32	L		Screw M 8 x 39 mm	x8		Phillips	Phillips Head Screwdriver	
D		Allen Key	x1	M		Screw M 6 x 10.5 mm	x8				
E		Screw M 7 x 50 mm	x4	N		Screw M 3.5 x 13 mm	x12				
F		Bracket	x4	O		Cam Lock Ø12 mm	x8				
G		Screw M 6.4 x 35 mm	x4	P		Wood Dowel Ø6 x 30 mm	x4				
H		Screw M 4.5 x 12.5 mm	x8	Q		Handle	x2				
I		Wedge	x12	R		Screw M 4 x 25 mm	x2				

Wait!

Missing parts or hardware? Need assistance?
Contact us before returning your item. We're here to help!
609.256.9000 • cs@modway.com

Step 1

HARDWARE

- A** Cam Bolt $\varnothing 6 \times 35$ mm x8
- P** Wood Dowel $\varnothing 6 \times 30$ mm x4

COMPONENTS

- 10** Front Drawer x2
- 11** Side Drawer Left x2
- 12** Side Drawer Right x2

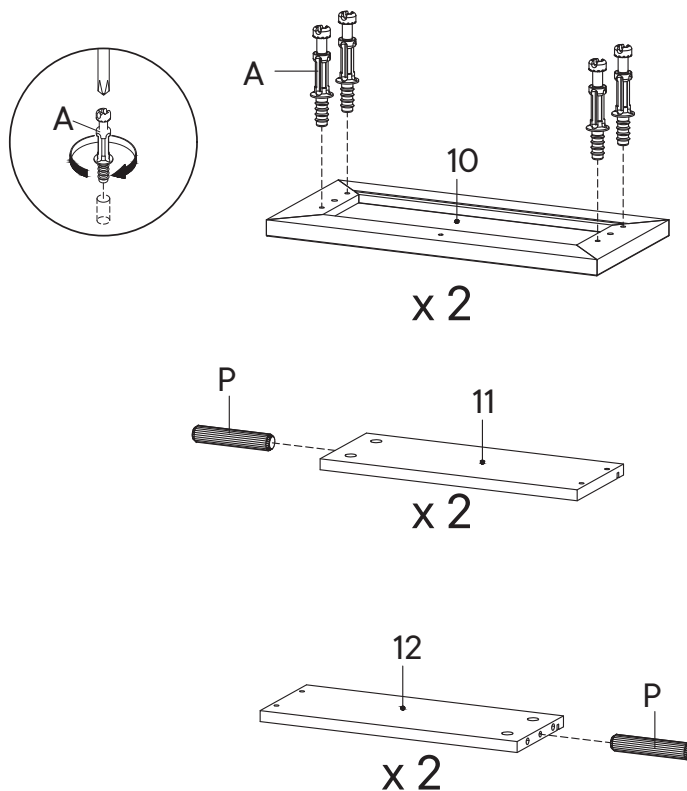

Step 2

HARDWARE

- L** Screw M 8 x 39 mm x8
- O** Cam Lock $\varnothing 12$ mm x8

COMPONENTS

- 10** Front Drawer x2
- 11** Side Drawer Left x2
- 12** Side Drawer Right x2
- 13** Back Drawer x2
- 14** Bottom Drawer x2

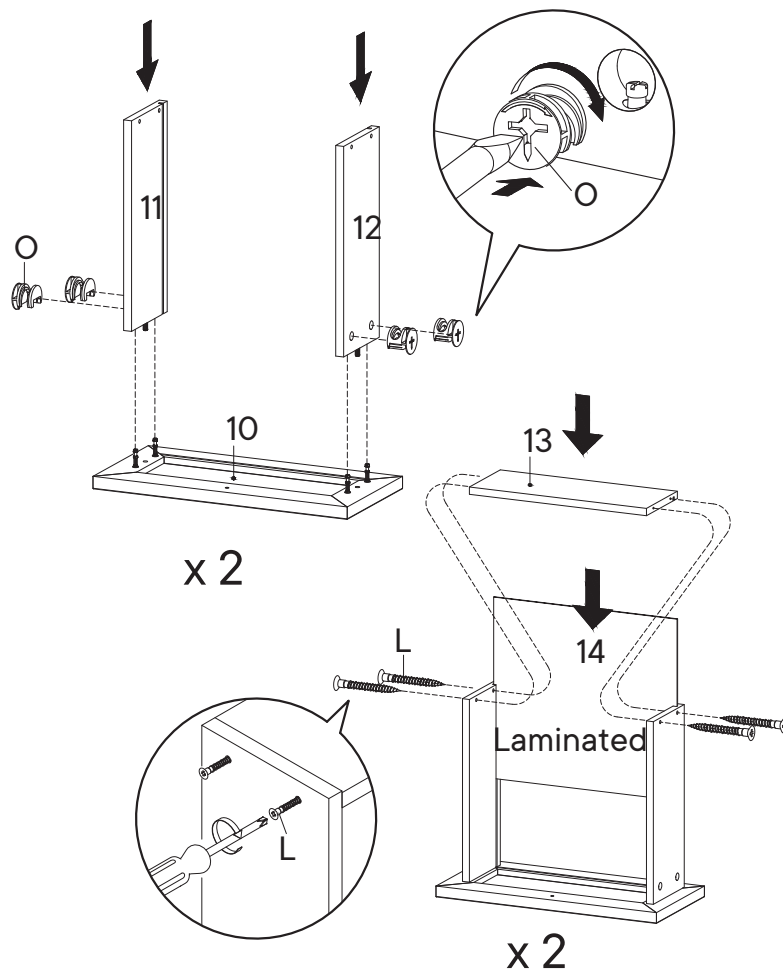

Step 3

HARDWARE

- N** Screw M 3.5 x 13 mm x12
- Q** Handle x2
- R** Screw M 4 x 25 mm x2
- RM30A** Drawer Runner x2

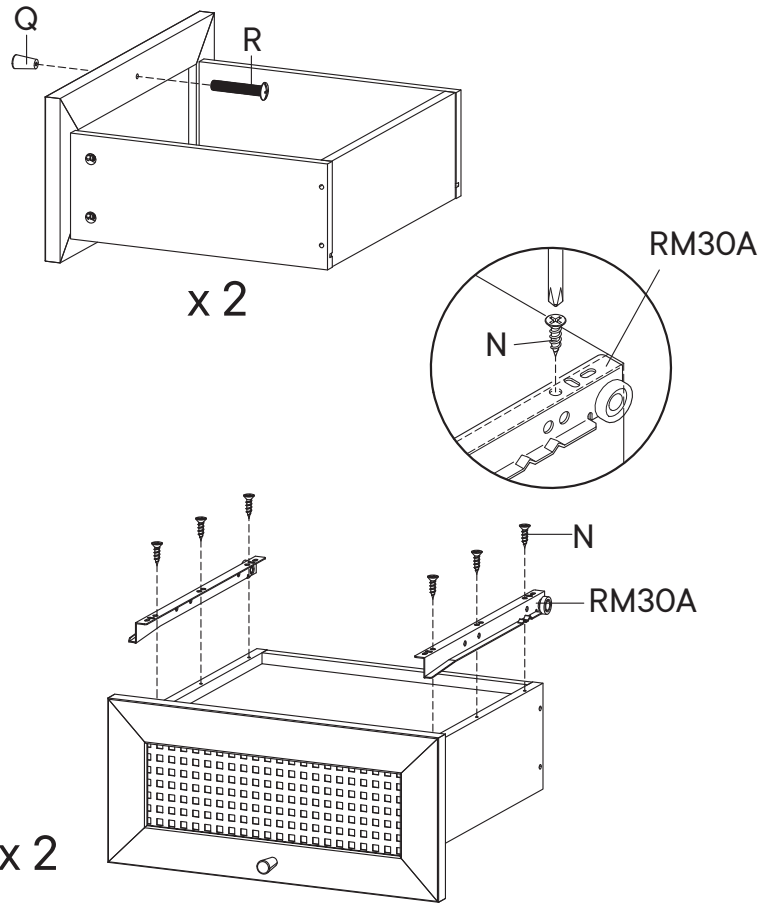

Step 4

HARDWARE

- I** Wedge x8
- J** Screw M 3.5 x 15.5 mm x8

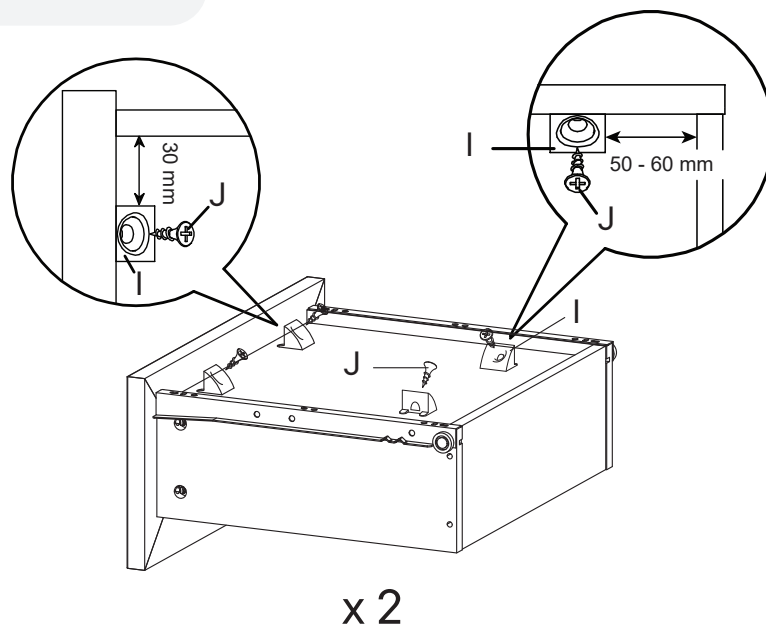

Step 5

HARDWARE

A	Cam Bolt $\varnothing 6 \times 35$ mm	x4
C	Wood Dowel $\varnothing 8 \times 30$ mm	x8
M	Screw M 6 x 10.5 mm	x8
RM30A	Drawer Runner	x2

COMPONENTS

1	Top Board	x1
3	Side Board Left	x1
4	Side Board Right	x1

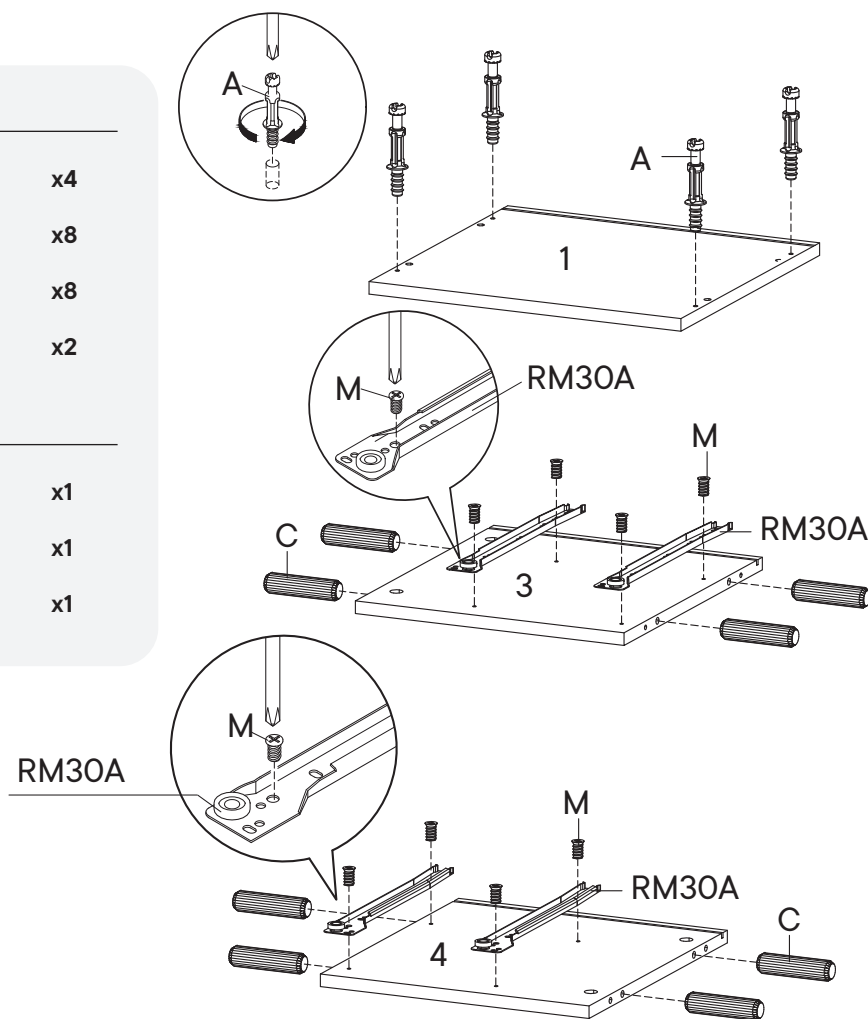

Step 6

HARDWARE

B	Cam Lock $\varnothing 15$ mm	x4
----------	------------------------------	----

COMPONENTS

1	Top Board	x1
3	Side Board Left	x1
4	Side Board Right	x1

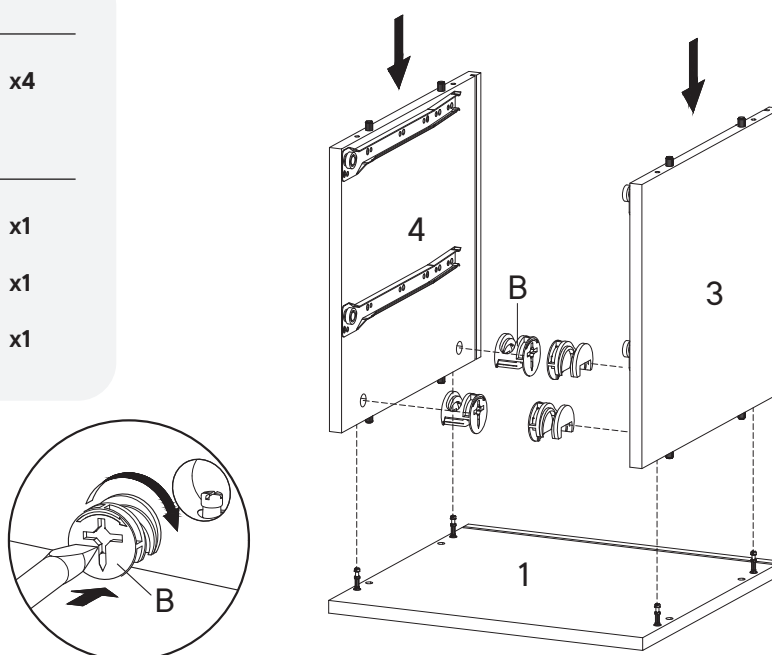

Step 7

HARDWARE

- D** Allen Key x1
- E** Screw M 7 x 50 mm x4

COMPONENTS

- 2** Bottom Board x1
- 5** Back Board x1

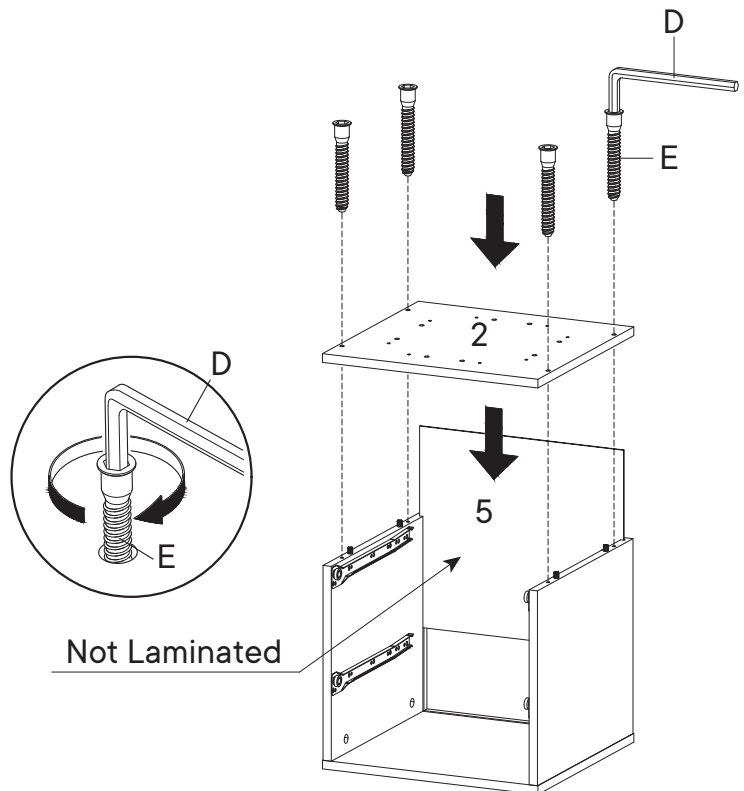

Step 8

HARDWARE

- A** Cam Bolt $\varnothing 6$ x 35 mm x8

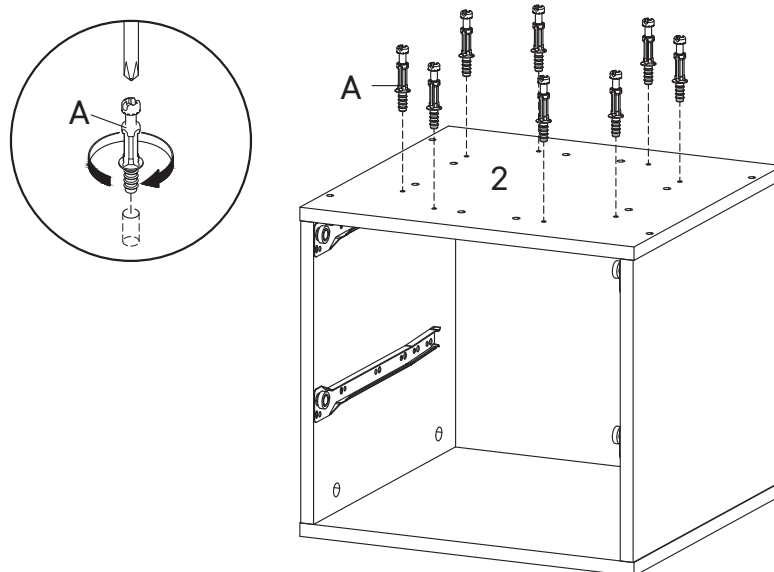

Step 9

HARDWARE

- C** Wood Dowel Ø8 x 30 mm x16
- K** Floor Protector x4

COMPONENTS

- 8** Leg 1 x2
- 9** Leg 2 x2

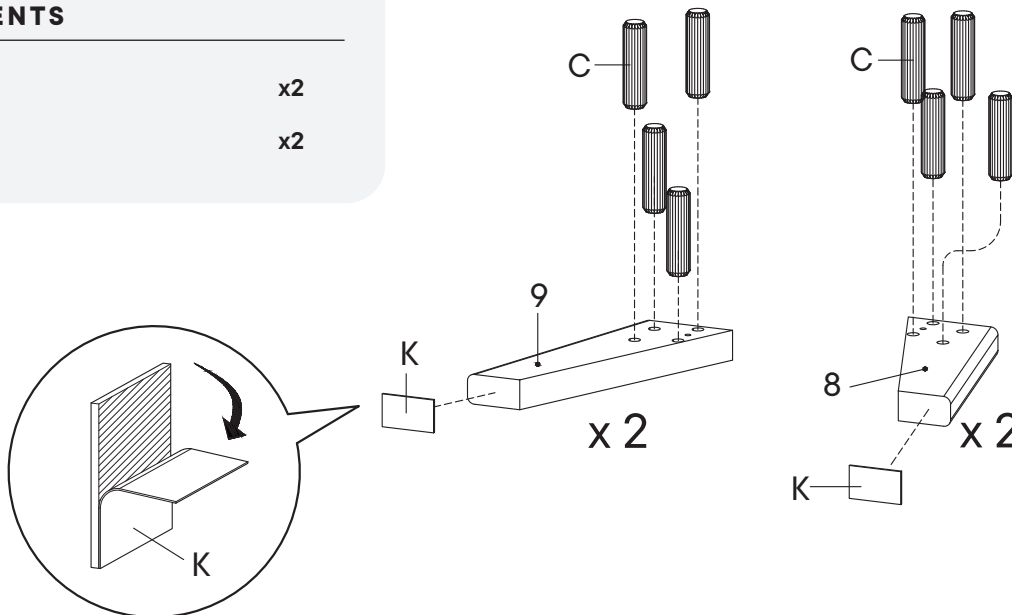
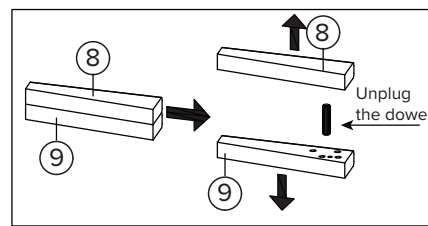

Step 10

HARDWARE

- F** Bracket x4
- H** Screw M 4.5 x 12.5 mm x8

COMPONENTS

- 7** Bottom Skirt 2 x2

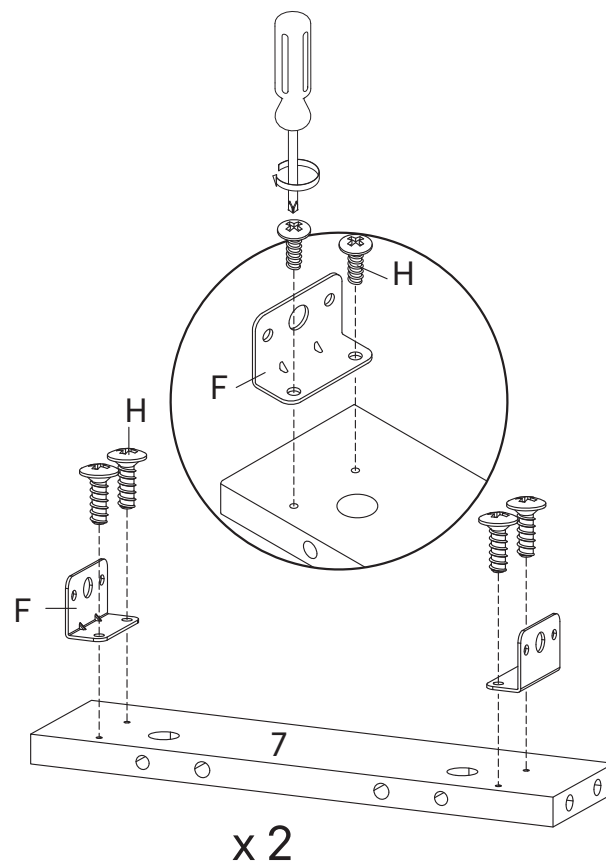

Step 11

COMPONENTS

- 6 Bottom Skirt 1 x2
- 7 Bottom Skirt 2 x2

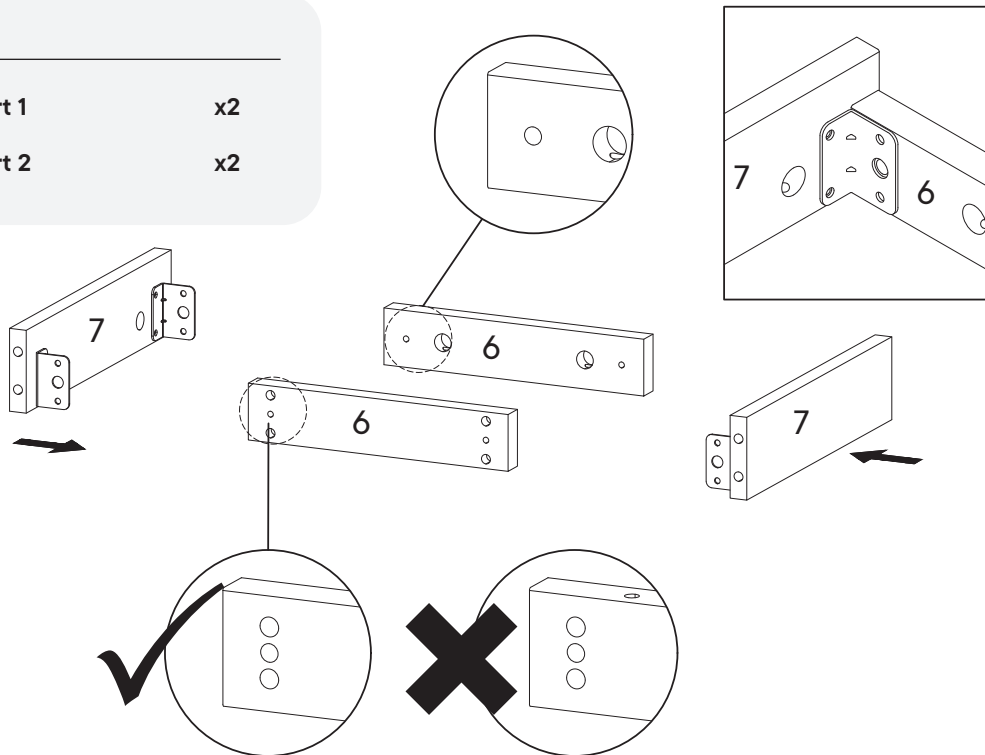

Step 12

COMPONENTS

- 8 Leg 1 x2
- 9 Leg 2 x2

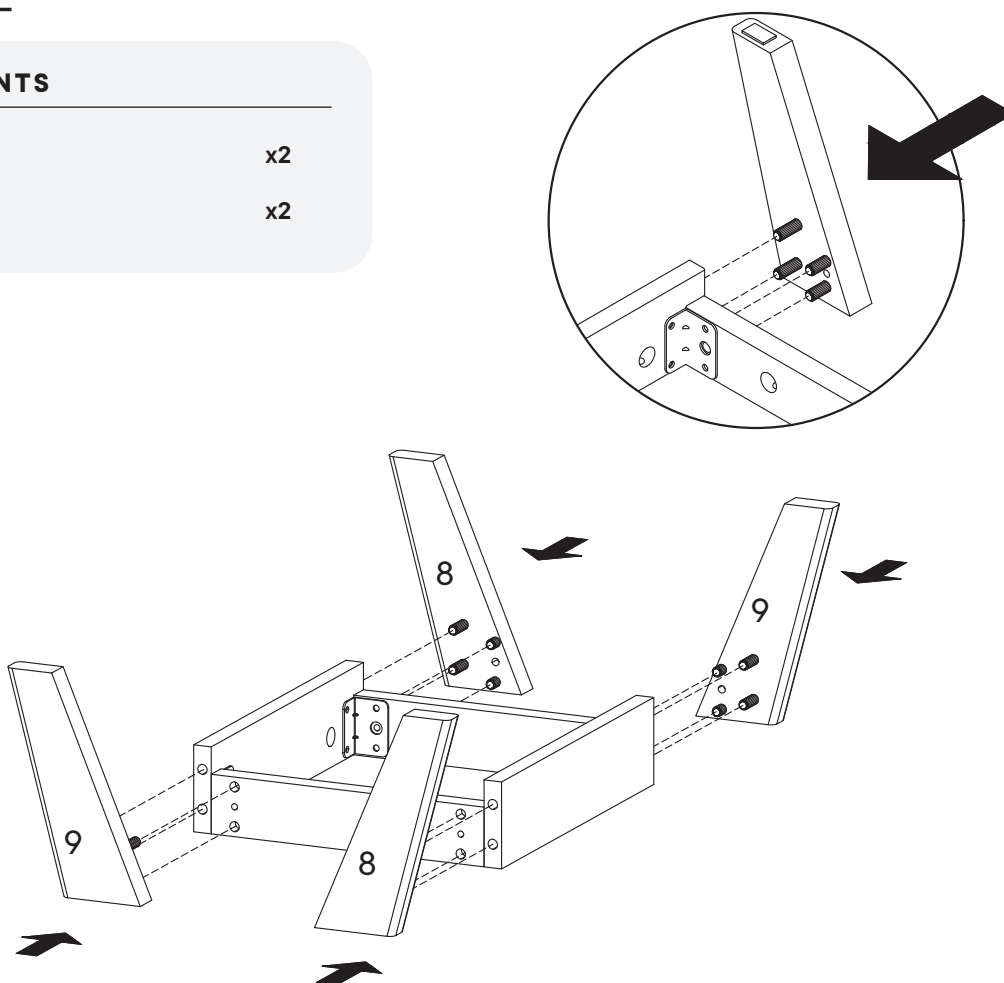

Step 13

HARDWARE

C Wood Dowel $\varnothing 8 \times 30$ mm x8

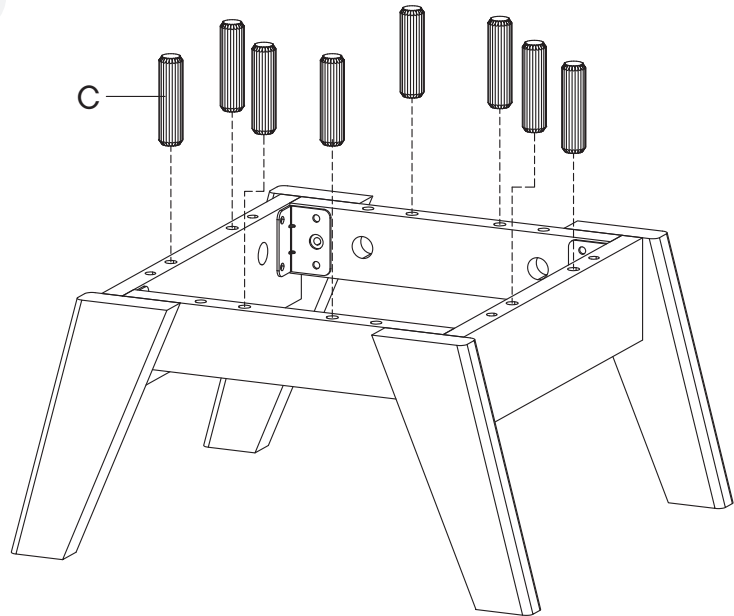

Step 14

HARDWARE

B Cam Lock $\varnothing 15$ mm x8

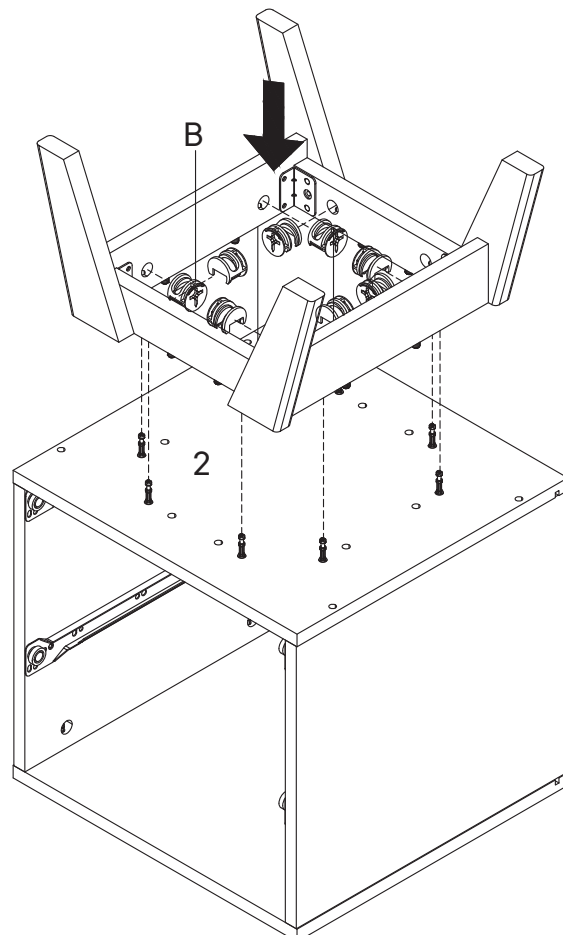
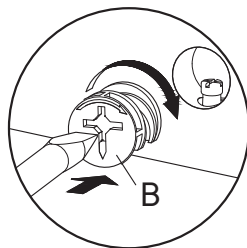

Step 15

HARDWARE

- D** Allen Key x1
- G** Screw M 6.4 x 35 mm x4

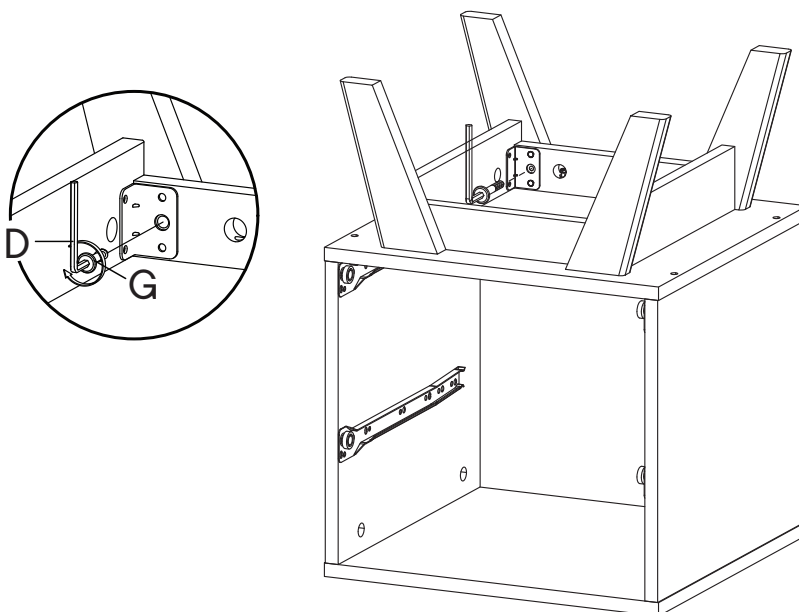

Step 16

HARDWARE

- I** Wedge x4
- J** Screw M 3.5 x 15.5 mm x4

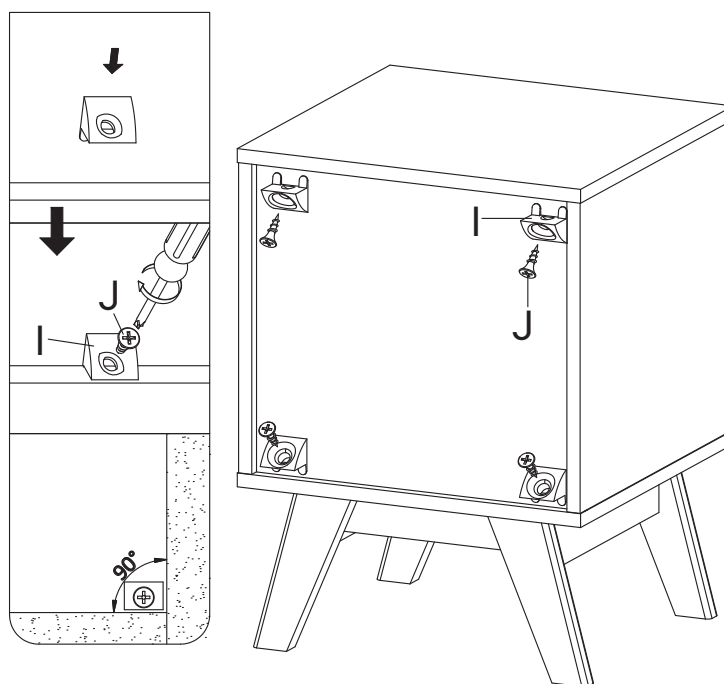

Step 17

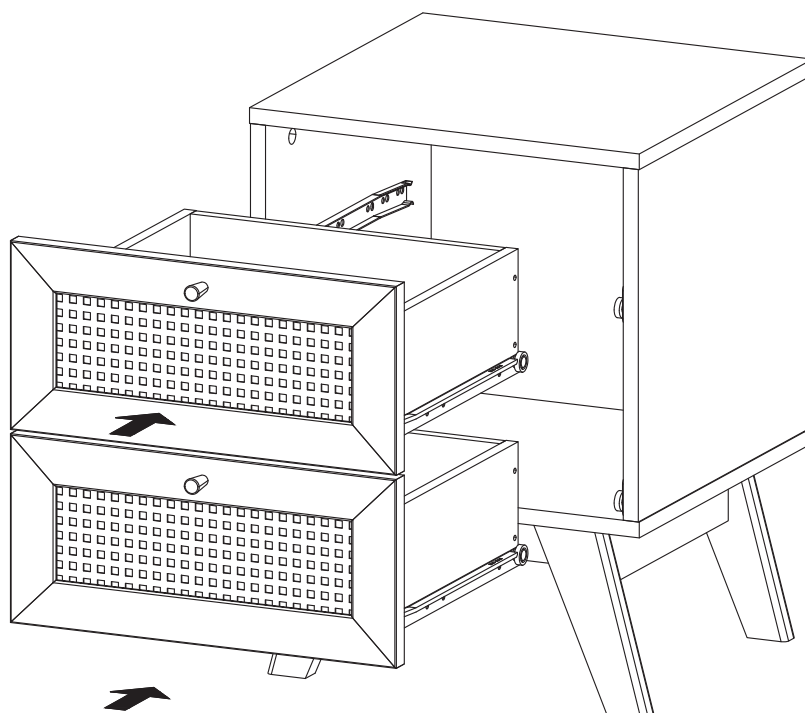
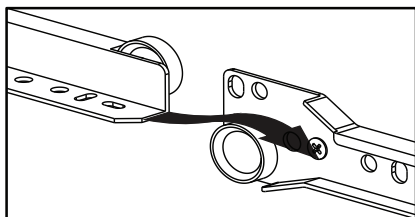

Great job!

Nightstand assembly is complete.

♥ CARING FOR YOUR ITEM

Indoor use only.

Not contract grade.

Clean using a non-abrasive cloth and a mild cleaner.

Never use harsh chemicals, as they could damage the finish or integrity of the item.

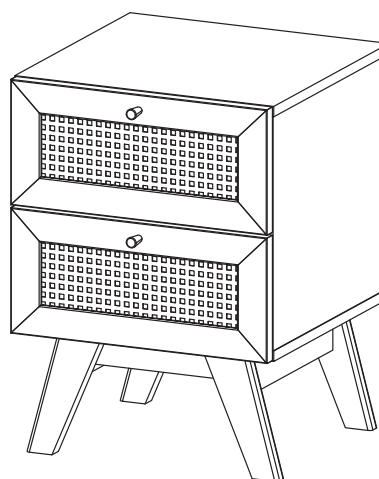

CONNECT WITH US!   

Tag us @modway_furniture and #modway for a chance to be featured.