

ASSEMBLY INSTRUCTION

RATTAN SOFA SET

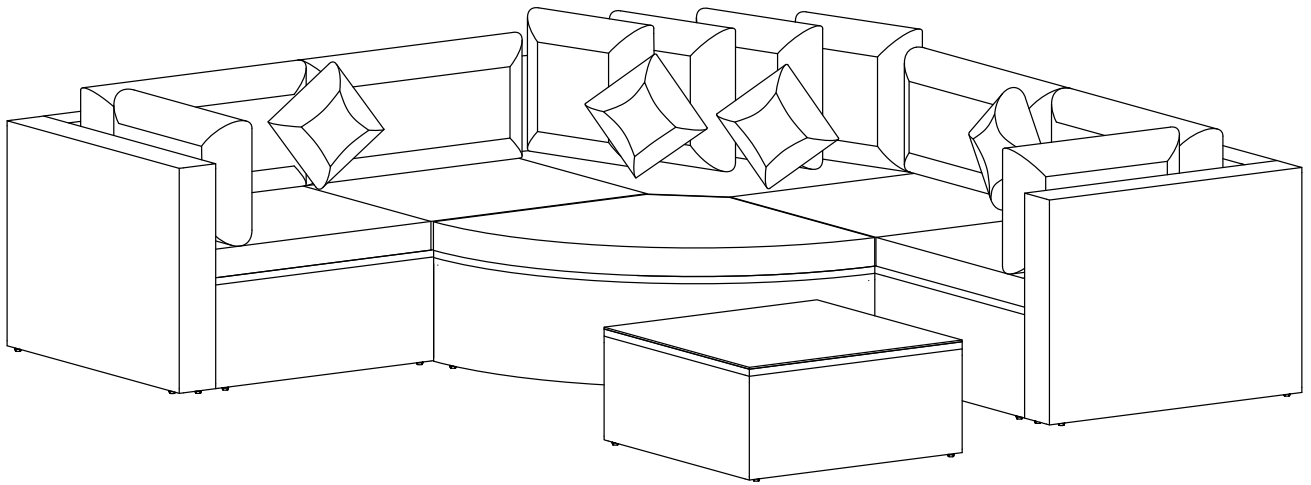

WF285053; WF285054; WF285055; WF285056

Notice

- 1. 50% Tighten before fixings all screws, Allen wrench is recommended instead of an electric drill.**
- 2. Place the item on a flat ground to adjust and make sure it remains stable.**
- 3. Tighten up all screws with tools gradually.**
- 4. If the screws are not aligned with holes during assembly, please loosen all all the other screws to 50% and continue the assembly process.**
- 5. If the item is not stable, please loosen all the screws, adjust it on a flat ground and tighten up all screws again.**
- 6. Note: If one or more screws are fully tightened during assembly, chances are the others will not be aligned with holes. In addition, all the holes are designed to be relatively larger to provide more space for the adjustment of the screws.**

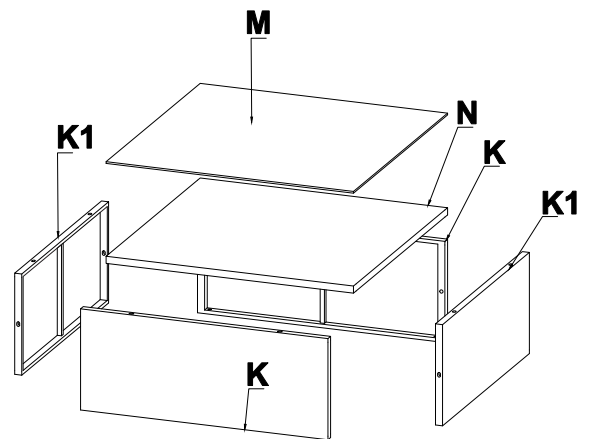
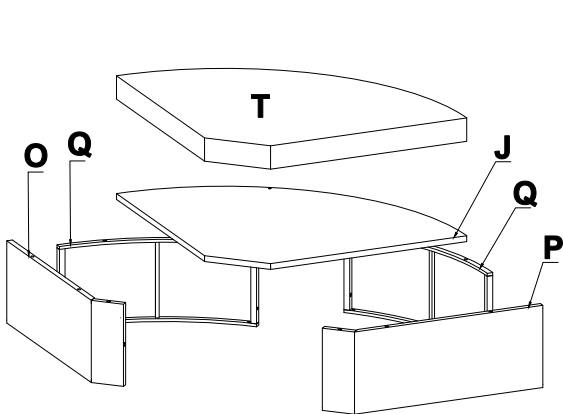
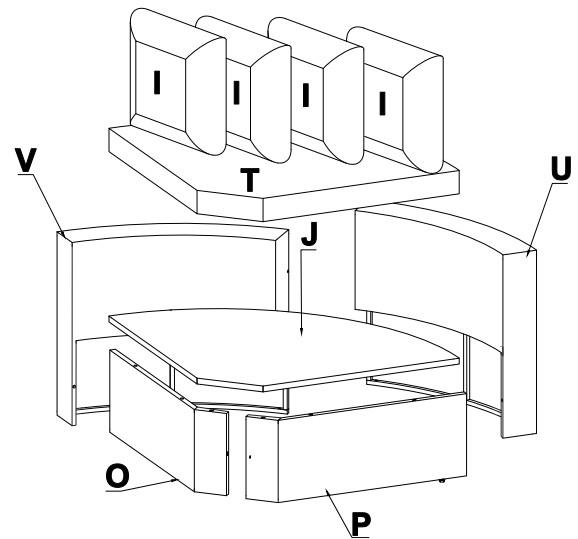
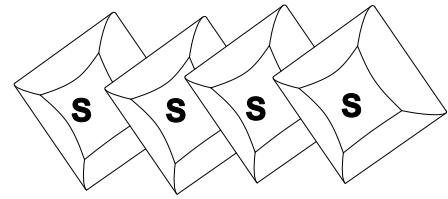
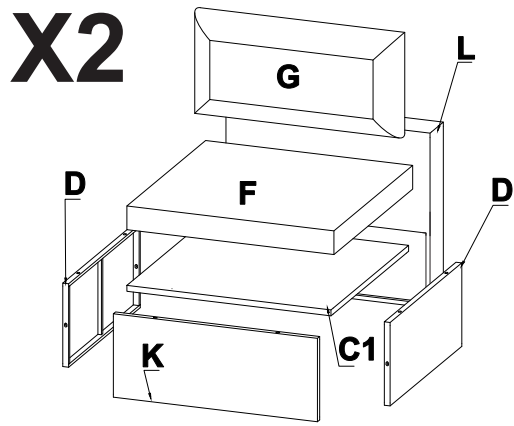
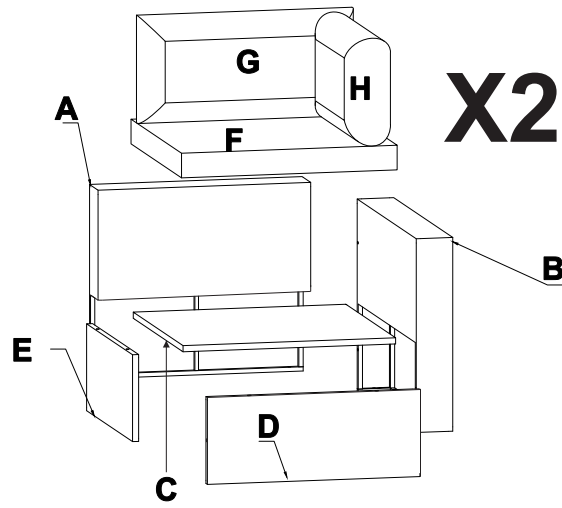

Part list & Hardware

A

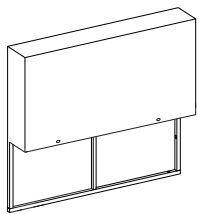

2 pcs

B

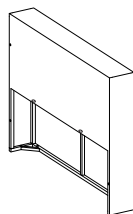

2 pcs

C

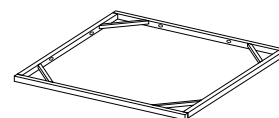

2 pcs

C1

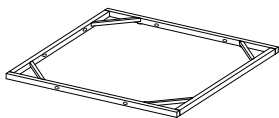

2 pcs

D

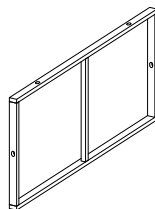

6 pcs

E

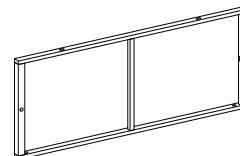

2 pcs

F

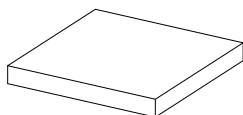

4 pcs

G

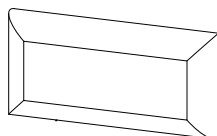

4 pcs

H

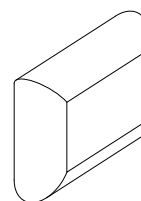

2 pcs

I

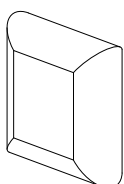

4 pcs

J

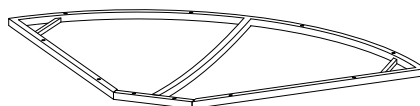

2 pcs

K

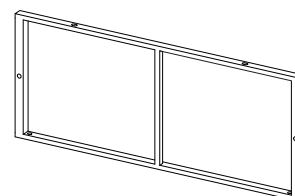

4 pcs

K1

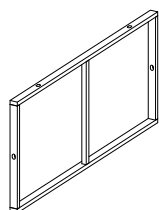

2 pcs

L

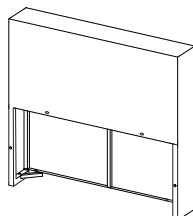

2 pcs

M

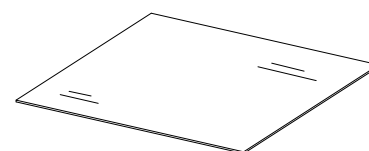

1 pc

N

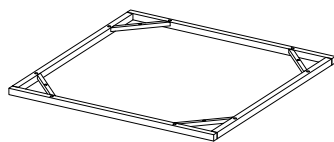

1 pc

O

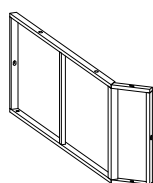

2 pcs

P

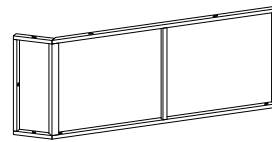

2 pcs

Part list & Hardware

Q

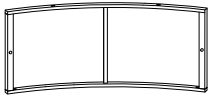

2 pc

S

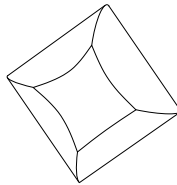

4 pcs

T

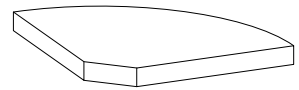

2 pcs

U

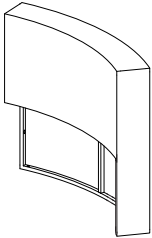

1 pc

V

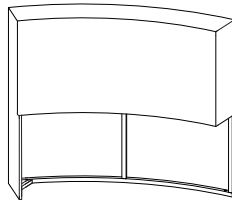

1 pc

1

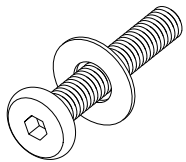

**Bolt M6x35 mm
(86 pcs)+ extra 3pcs**

2

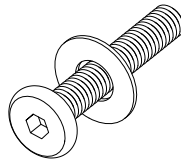

**Bolt M6x15 mm
(10 pcs)+ extra 2pcs**

3

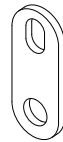

Connector (5 pcs)

4

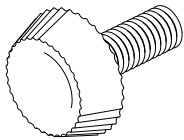

Plastic feet (44 pcs)

5

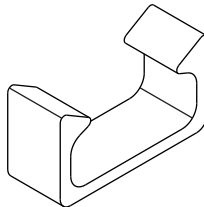

**Plastic connector
(8 pcs)**

6

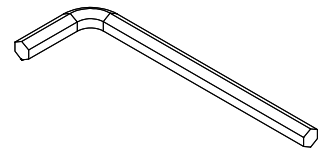

Allen key M4 (2 pcs)

7

WF 285053

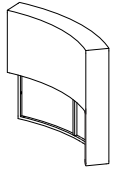

U * 1

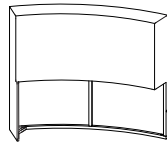

V * 1

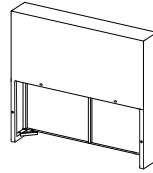

L * 1

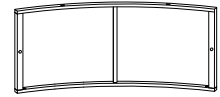

Q * 2

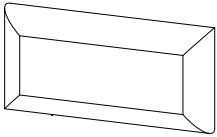

G * 1

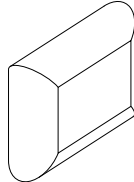

H * 2

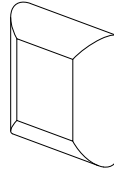

I * 4

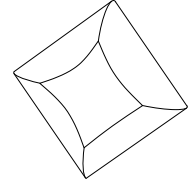

S * 4

WF 285054

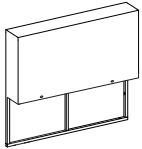

A * 2

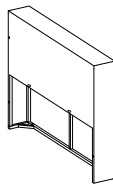

B * 2

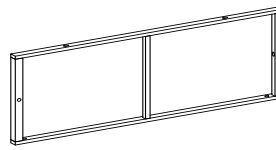

E * 2

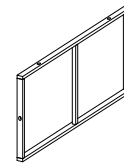

D * 4

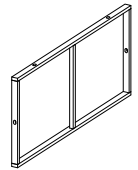

K1 * 2

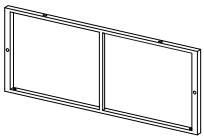

K * 4

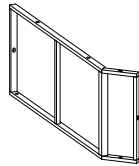

O * 2

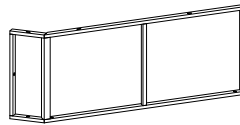

P * 2

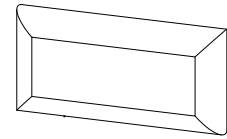

G * 3

WF 285055

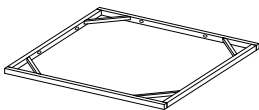

C * 2

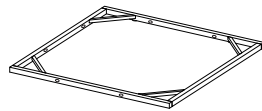

C1 * 2

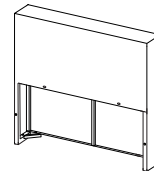

L * 1

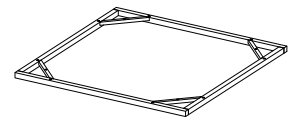

N * 1

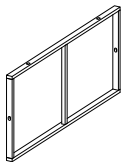

D * 2

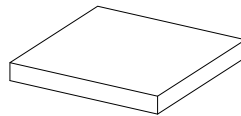

F * 4

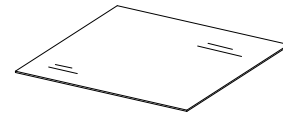

M * 1

WF 285056

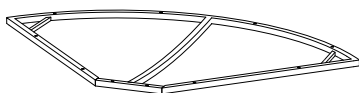

J * 2

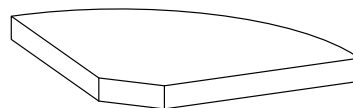

T * 2



HARDWARE

STEP 1x2

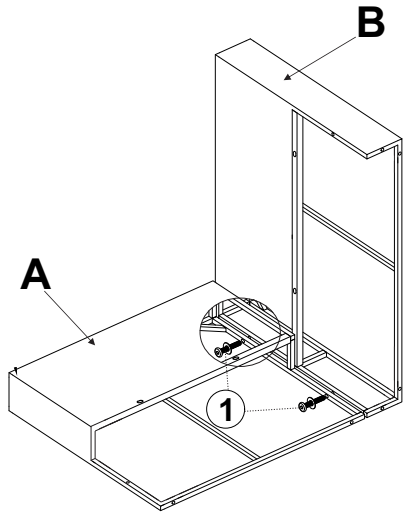
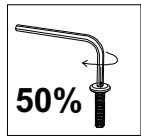
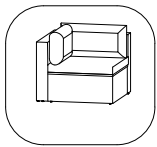

①*2

STEP 2x2

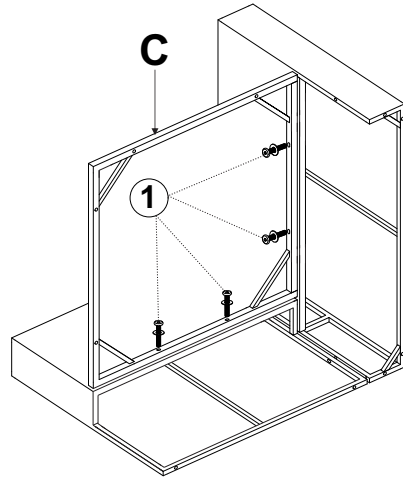
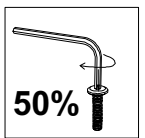
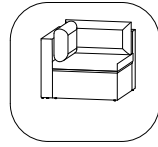

①*4

STEP 3x2

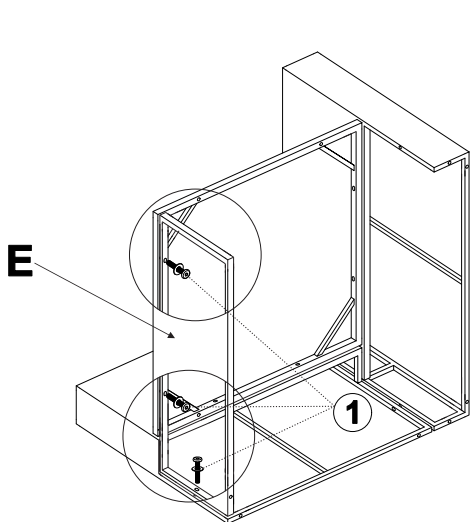
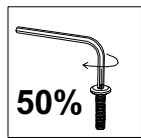
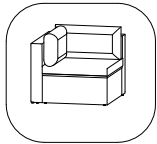

①*3

STEP 4x2

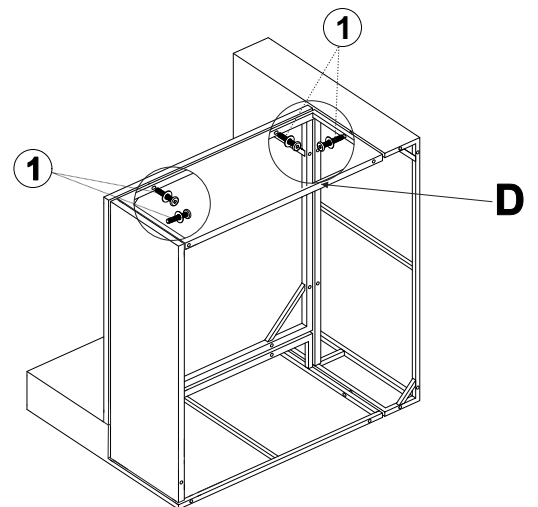
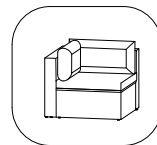

①*4

STEP 5x2

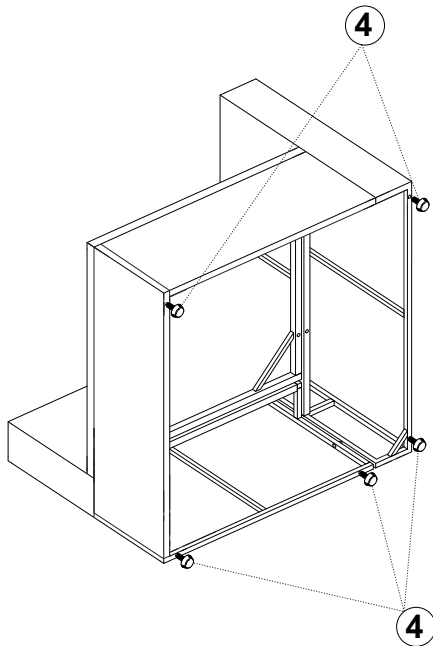
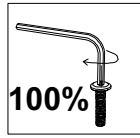
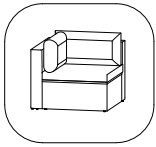

4*5

STEP 6x2

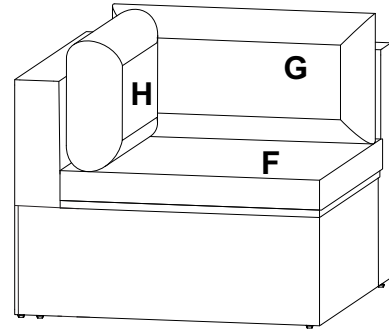
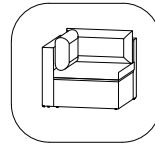

STEP 7x2

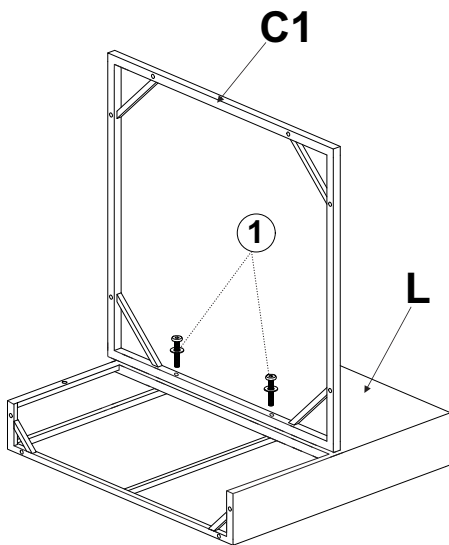
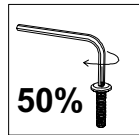

1*2

STEP 8x2

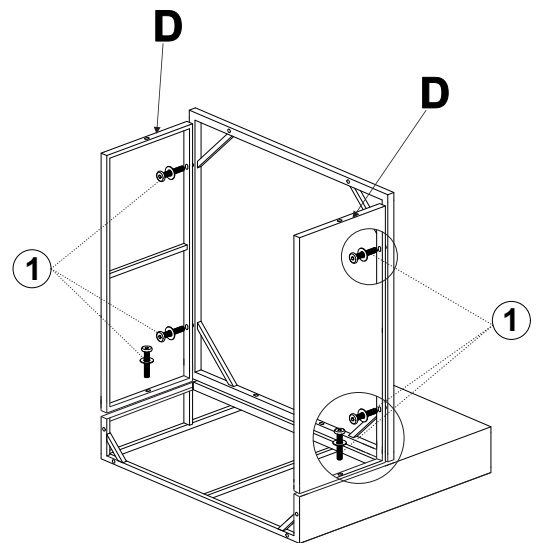
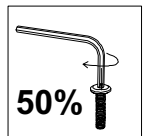
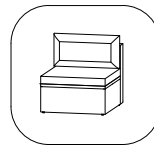

1*6

STEP 9x2

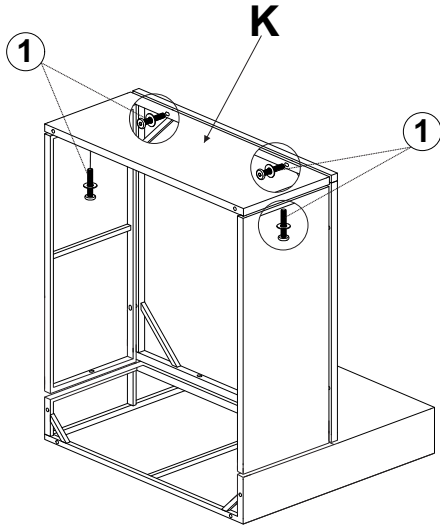
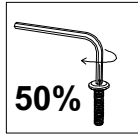
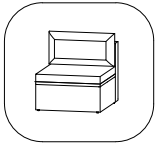

1*4

STEP 10x2

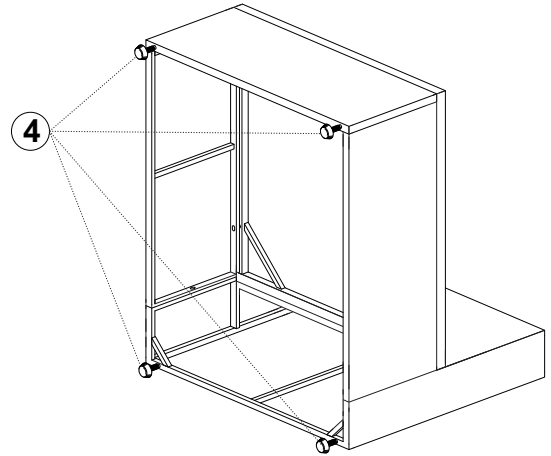
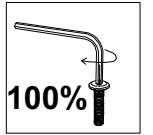
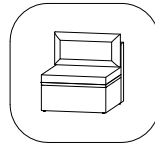

4*4

STEP 11x2

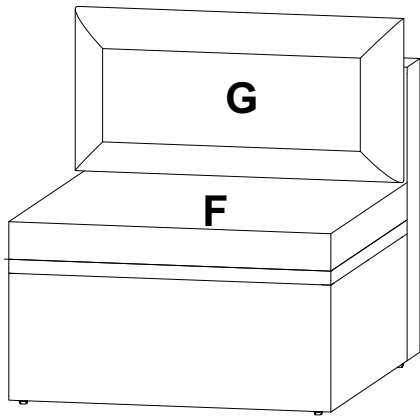

STEP 12

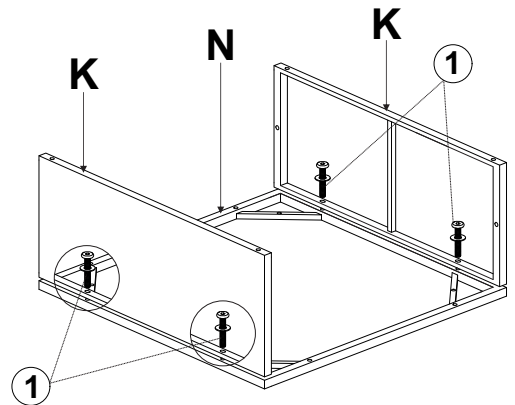
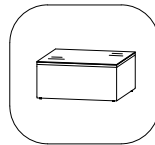

1*4

STEP 13

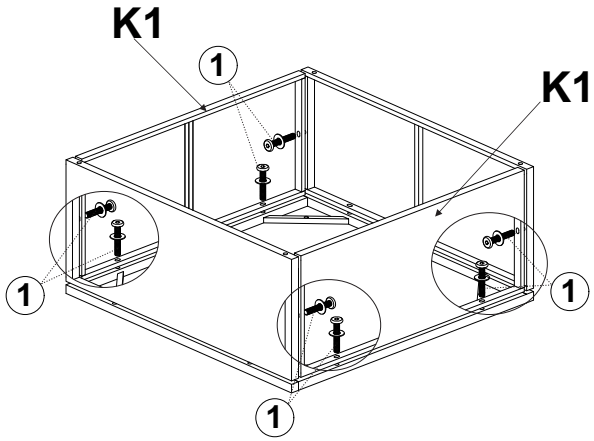
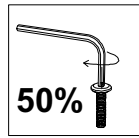
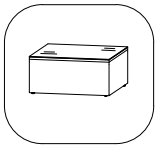

1*8

STEP 14

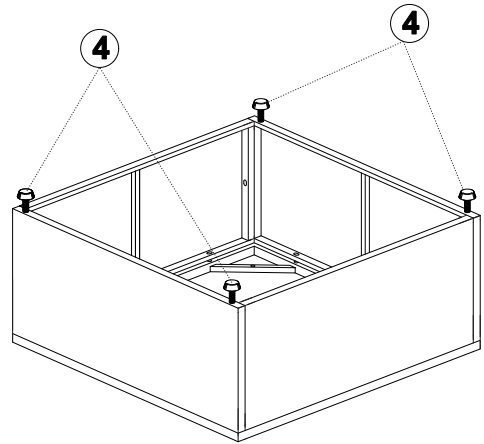
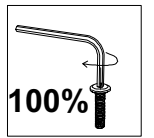
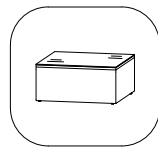

4*4

STEP 15

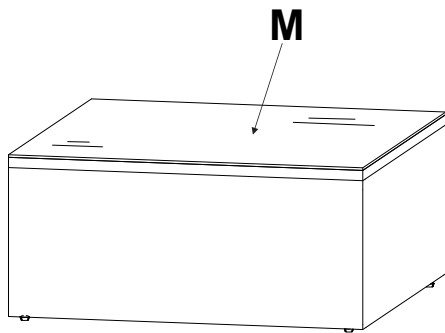
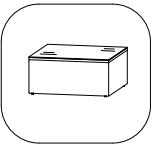

STEP 16

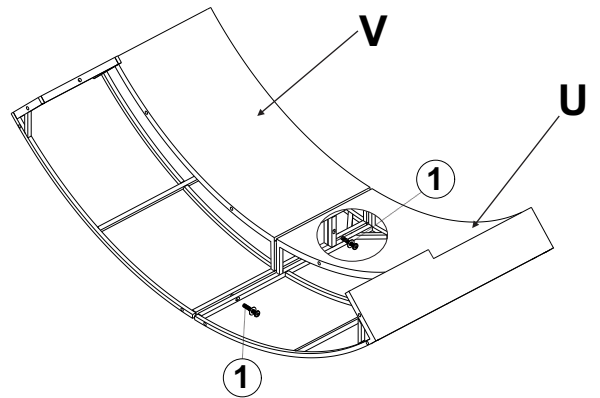
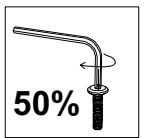
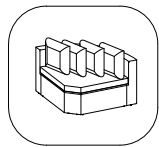

1*2

STEP 17

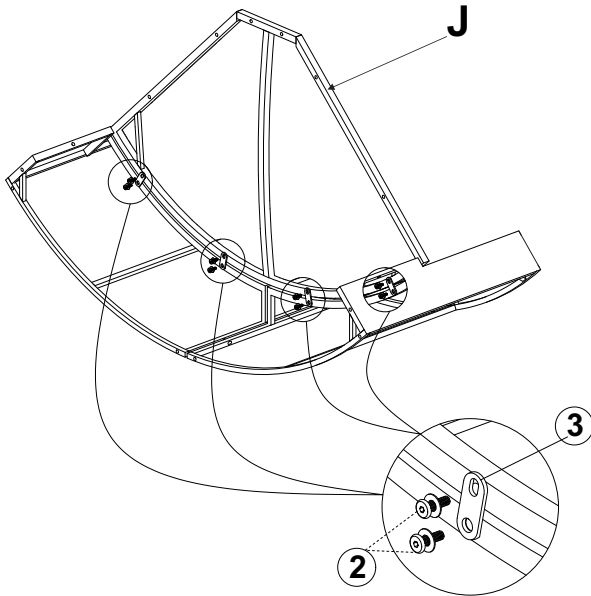
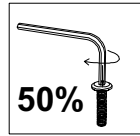
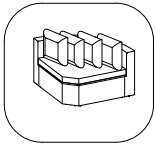

2*8 3*4

STEP 18

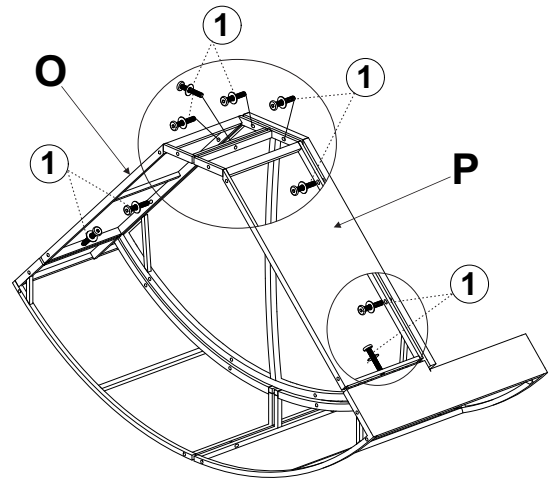
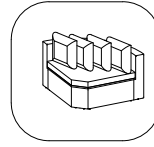

1*9

STEP 19

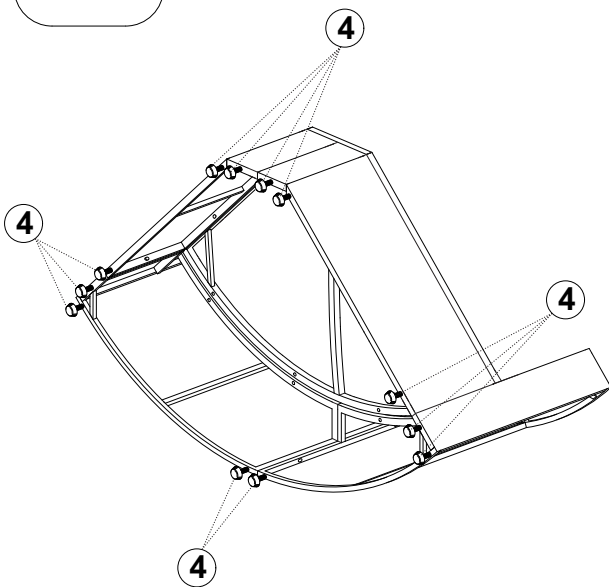
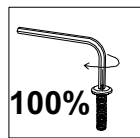
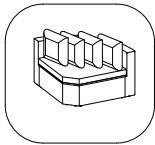

4*12

STEP 20

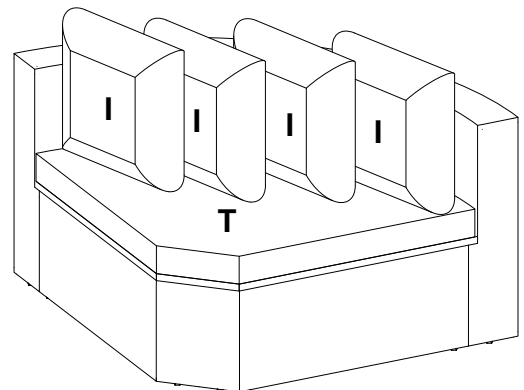
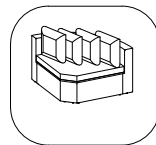

STEP 21

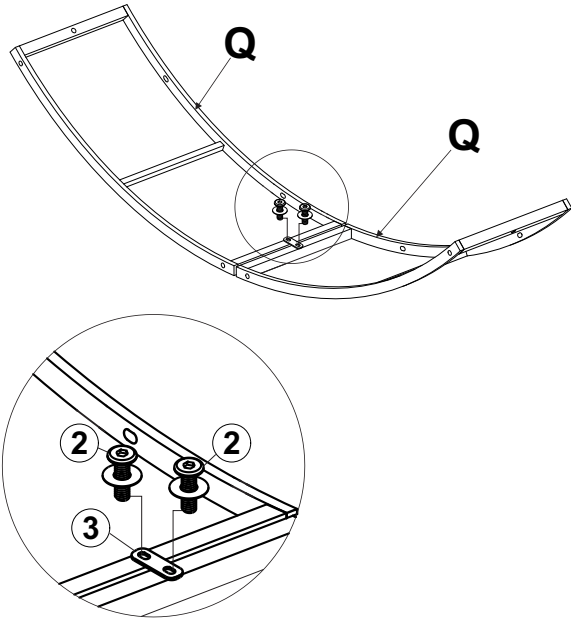
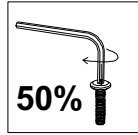
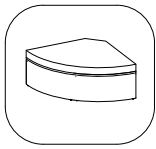

②*2 ③*1

STEP 22

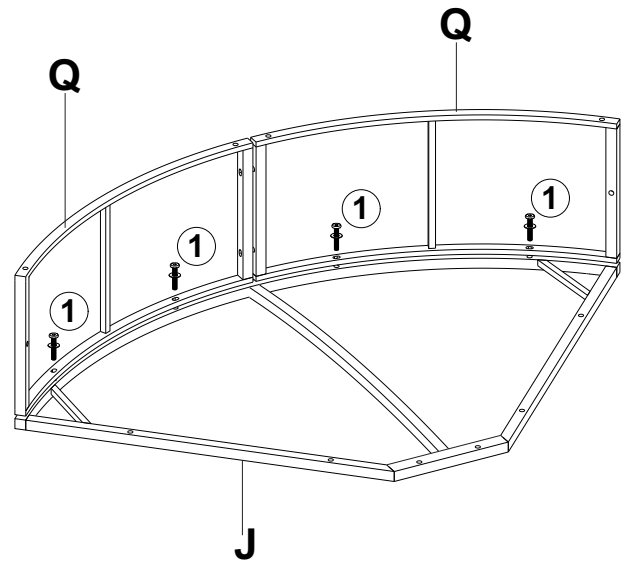
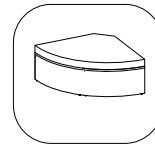

①*4

STEP 23

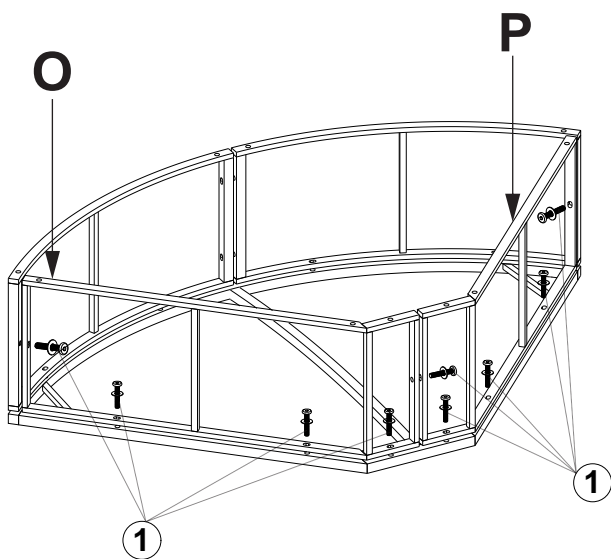
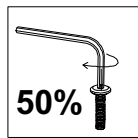
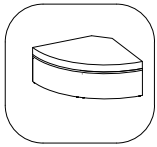

①*9

STEP 24

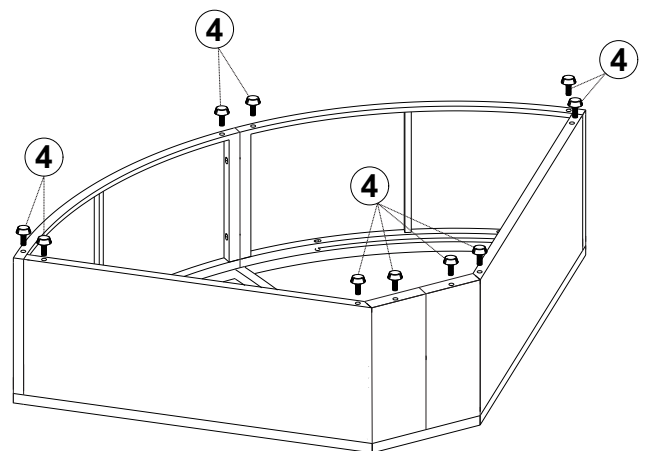
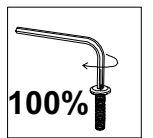
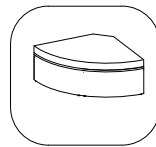

④*10

STEP 25

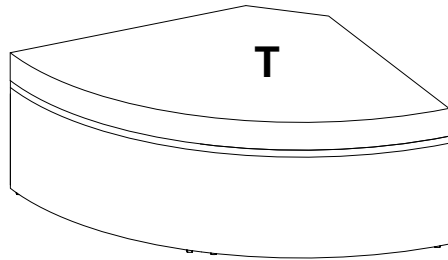
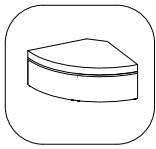

STEP 26

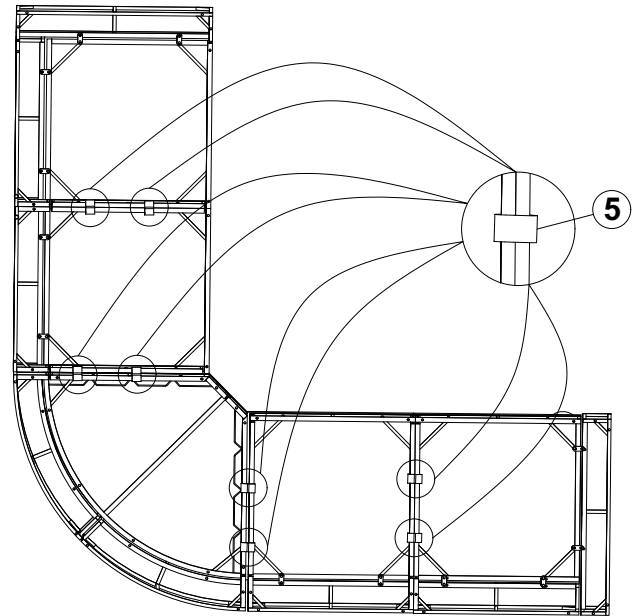

⑤*8

STEP 27

