

SERVICE DATA SHEET GAS RANGES WITH PRO OVEN CONTROLS

NOTICE: This service data sheet is intended for use by persons having electrical and mechanical training and a level of knowledge of these subjects generally considered acceptable in the appliance repair trade. The manufacturer cannot be responsible, nor assume any liability, for injury or damage of any kind arising from the use of this data sheet.

IMPORTANT NOTE: This unit includes an EOC (electronic oven control). This board is not field-repairable. Verify the unit has the proper oven relay board, oven user interface board, and touch panel based on the model number and parts catalog.

Safe Servicing Practices

To avoid the possibility of personal injury and/or property damage, it is important that safe servicing practices be observed. The following are some, but not all, examples of safe practices.

- Do not attempt a product repair if you have any doubts as to your ability to complete it in a safe and satisfactory manner.
- Before servicing or moving an appliance, remove power cord from electric outlet, trip circuit breaker to Off, or remove fuse.
- Never interfere with the proper installation of any safety device.

- Use only replacement parts specified for this appliance. Substitutions may not comply with safety standards set for home appliances.
- Grounding: The standard color coding for safety ground wires is green or green with yellow stripes. Ground leads are not to be used as current carrying conductors. It is extremely important that the service technician reestablish all safety grounds prior to completion of service. Failure to do so will create a potential hazard.
- Prior to returning the product to service, ensure that:
 - All electric connections are correct and secure.
 - All electrical leads are properly dressed and secured away from sharp edges, high-temperature components, and moving parts.
 - All uninsulated electrical terminals, connectors, heaters, etc. are adequately spaced away from all metal parts and panels.
 - All safety grounds (both internal and external) are correctly and securely reassembled.
 - All panels are properly and securely reassembled.

Temperature Adjustment

Refer to the Use & Care Manual for directions on how to adjust the oven temperatures.

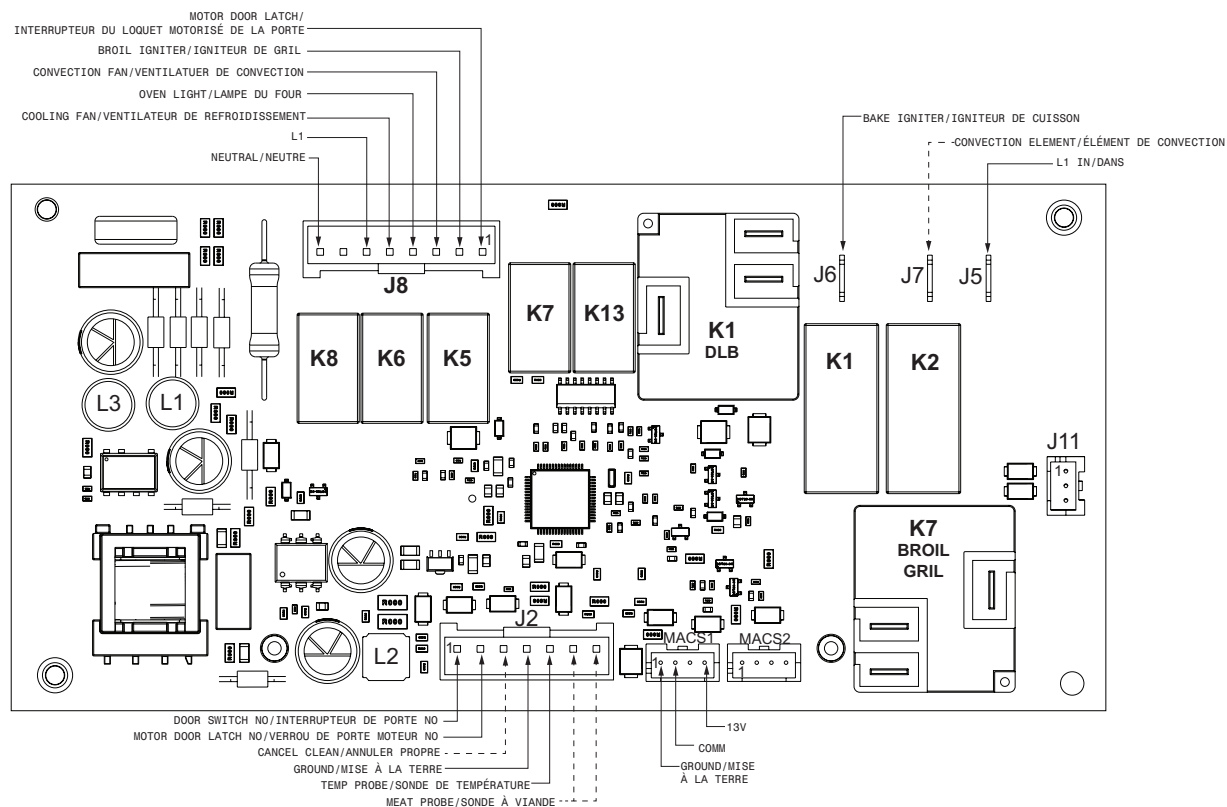

RTD SCALE ÉCHELLE DU DÉTECTEUR DE TEMPÉRATURE À RÉSISTANCE	
Temperature Température °F (°C)	Resistance Résistance (ohms)
32 ± 1.9 (0 ± 1.0)	1000 ± 4.0
75 ± 2.5 (24 ± 1.3)	1091 ± 5.3
250 ± 4.4 (121 ± 2.4)	1453 ± 8.9
350 ± 5.4 (177 ± 3.0)	1654 ± 10.8
450 ± 6.9 (232 ± 3.8)	1852 ± 13.5
550 ± 8.2 (288 ± 4.5)	2047 ± 15.8
650 ± 9.6 (343 ± 5.3)	2237 ± 18.5
900 ± 13.6 (482 ± 7.5)	2697 ± 24.4
Probe circuit to case ground Circuit de la sonde mise à la terre à la caisse	Open circuit/infinite resistance Circuit ouvert/résistance infinie

CIRCUIT ANALYSIS MATRIX									
	Bake Ignitor J6	Broil Ignitor J8-2/K4	Convection Element J7	Door Motor J8-1	Light J8-4	Cooling Fan J8-5	Convection Fan J8-3	Door Switch J2-1	
Bake	X		X			X	X		
Broil		X				X			
Conv. Bake	X		X			X	X		
Conv. Roast	X		X			X	X		
Clean	X					X			
Locking				X					
Unlocking				X					
Light					X				
Door Open					X				
Door Closed									X

MEAT PROBE TEMPERATURE VS RESISTANCE TABLE	
Temperature	Probe Resistance
77 °F / 25 °C	50.020 Kohm +/- 6%
122 °F / 50 °C	18.020 Kohm +/- 5%
176 °F / 80 °C	6.290 Kohm +/- 5%
212 °F / 100 °C	3.400 Kohm +/- 5%

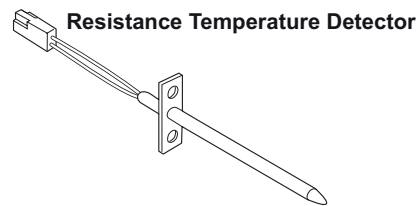

ELECTRONIC OVEN CONTROL (EOC) FAULT CODE DESCRIPTIONS

Fault Code	Description of Error Code	Suggested Corrective Action
F1	Internal alarm (microcontroller)	Disconnect power, wait 30 seconds and reapply power. If problem persists, replace control assembly.
F2	HMI data flash alarm	
F3	Configuration checksum alarm (OUI cooking function)	
F4	Keyboard tuning configuration alarm (key-board safety alarm)	
F5		
F10	Oven temperature runaway	Check RTD sensor and replace if necessary. If the oven is overheating, disconnect power, if problem persist replace relay board. Severe overheating may require the entire oven to be replaced when damage is extensive.
F11	Short key/stuck key	<ol style="list-style-type: none"> If a key is pressed inadvertently for a long time this error code will be displayed. Make sure that there is nothing (water, utensils) in contact with the key-board. The error code should go away once the key is released and the stop key is pressed. If the error comes back when any key is pressed it means that the error is still present. If the error does not come back it means the error condition is gone and the oven can be used. If the fault cannot be cleared, test the wiring harness between oven user interface board (connector I2C1 or I2C2). If the fault code cannot be cleared and the wiring is good, the touch panel is most likely defective: replace the control assembly (HMI and touch panel).
F12	Keyboard configuration alarm: the oven user interface received a key that does not match the key map from the HMI touch panel.	Disconnect power, wait 30 seconds and reapply power. If problem persists, replace touch control assembly and OUI.
F13	OUI data flash alarm (non-volatile memory alarm)	Disconnect power, wait 30 seconds and reapply power. If problem persist replace OUI.
F15	Keyboard error, unable to read cancel key	Disconnect power, wait 30 seconds and reapply power. If problem persists, replace touch control assembly.
F16	Potentiometer failure alarm	Disconnect power, wait 30 seconds and reapply power. Verify harness between potentiometers and OUI. Replace Oven Potentiometer. If problem persists, replace control and potentiometers.
F17	The oven user interface is unable to configure HMI alarm	Disconnect the power for 30 seconds and reapply power. If the problem persist check the I2C1 or I2C2 harness connections. If the error persists replace touch control assembly.
F18	Oven relay board failure (wiggler)	Replace power board PCB (OVC).
F19	The OUI is unable to configure the OVC	Disconnect power for 30 seconds, then reapply power. If fault returns, verify connection between the OUI and OVC (MACS1 or MACS2). If error persists, replace OUI and/or OVC.
F22	Communication failure between OUI and OVC	Verify correct voltage across the system. Disconnect power for 30 seconds, then reapply power. If error persists, check the MCS1 or MACS 2 wiring harness connection. If harness is good replace OUI and/or OVC.
F23	Communication failure between the touch panel (HMI) and the user interface (OUI)	Verify correct voltage across the system. Disconnect power for 30 seconds, then reapply power. If error persists check the wiring harness between the HMI and OUI, test I2C1 or I2C2. If problem persists, replace HMI (touch panel assembly) and /or OUI.
F25	Communication failure between the touch panel(HMI) and the user interface (OUI)	Verify correct voltage across the system. Disconnect power for 30 seconds, then reapply power. If error persists, check the MCS1 or MACS 2 wiring harness connection. If problem persists, replace OUI and/or touch panel assembly.
F27		
F29	Communication between touch panel and oven user interface cannot be initiated.	Verify correct voltage across the system. Disconnect power for 30 seconds, then reapply power. If error persists, check the wiring harness for I2C1 or I2C2. If error persists, replace HMI and /or OUI.
F30	Open probe or connection	Check resistance at room temperature and compare to RTD sensor resistance chart, if resistance don't match replace RTD sensor probe, check harness between the RTD and OVC.
F31	Short temp probe	Check resistance at room temperature and compare to RTD sensor resistance chart. If resistance don't match replace RTD sensor probe, check harness between the RTD and OVC.
F33	Meat probe temperature sensor shorted or too hot.	The error is triggered if the meat probe sees a temperature in excess of 393°F. Make sure the meat probe was not used in such way that it could have seen such temperature. Meat probe is not fully inserted. Verify Meat Probe resistance at room temperature. Compare meat probe resistance chart. If don't match replace the meat probe. If the error persists, replace the OVC board.
F45	Cooling fan speed too low	Check if cooling fan blades are blocked. Confirm tachometer harness is connected on fan and oven control. Replace cooling fan. Replace oven control
F46	Cooling fan speed too high	Check for mechanical obstruction in the air path. Replace cooling fan. Replace oven control
F50	A/D out of range, oven control is unable to read switches status (door, MDL)	Check connection between the door switch, MDL, and temp probes are properly connected, including splices and junctions. If problem persists, replace relay board.
F61	Missing zero cross signal OVC	Disconnect power to the unit, wait 30 seconds and reapply power. If fault return test continuity of hardness between OVC and power supply. Replace OVC.
F90	Maximum oven door unlock time exceeded	<ol style="list-style-type: none"> Disconnect power to the unit, wait 30 seconds, then reapply power. Try again to make the door lock or unlock. Check if the lock motor is running or not. If not running, test the wiring between the lock motor and the oven relay board. If the wiring is good check if there is 120 VAC at the motor when is expected to run to see if the failure originates from a bad motor (120VSC present but no turning) or the problem is the relay board (J20 pin 10 on the oven relay board is the output to MDL). The motor can also be tested applying 120VSC directly to the motor (unplug from relay board first). If the motor doesn't turn, replace the MDL assembly. If the relay board is not supplying 120 VAC to the motor, replace the relay board. If the lock motor is running but the oven control cannot find the locked position (ex: the MDL turns until F90 occurs) tverify the lock switch. Check the wiring between the lock switch and the relay board. Verify with the ohmmeter if the switch makes contact properly. If all steps above fail replace the oven relay board.
F95	Motor door lock mechanism failure. The MDL does not stop running or the lock switch sends an invalid signal.	The problem can be caused by a faulty lock switch or by a defective oven relay board. If the MDL is always running (as if the relay controlling, it is stuck closed) replace the relay board. If the motor is not always running replace the motor lock assembly.
F96	The oven door has been detected open during a self-clean cycle.	<ol style="list-style-type: none"> This error occurs if the door switch has lost contact during a self-clean cycle. Make sure the oven door closes well and fully presses on the door switch plunger when the door is locked, and no one attempted to pull on the oven door during the self-clean cycle. Test continuity of wiring between the door switch and the oven relay board, make sure the door switch is well connected. With the ohmmeter verify the switch is closed when the plunger is pressed. If the door switch is found to be defective, replace the door switch. If the above steps fail to fix the problem, replace the relay board.
F97	MDL invalid state, relay board (OVC) sensed the MDL in a state it should not be in.	Disconnect the power to the unit, wait 30 seconds, then reapply power. If problem persists, replace MDL assembly. If fault persists, replace relay board.
SCC	The oven control display shows "SCC" and self-clean is not working.	If the cooktop is used during a self-clean cycle, the oven may turn off. The oven control display will show "SCC" for 5 seconds. The oven door will remain locked until the oven has cooled down below cleaning temperature. If the oven is below cleaning temperature, the user can start another clean cycle immediately. If the oven is in cleaning temperature range, another self-clean cycle can be set once the door unlocks (up to 4 hours).

IMPORTANT
DO NOT REMOVE THIS BAG
OR DESTROY THE CONTENTS
WIRING DIAGRAMS AND SERVICE
INFORMATION ENCLOSED
REPLACE CONTENTS IN BAG

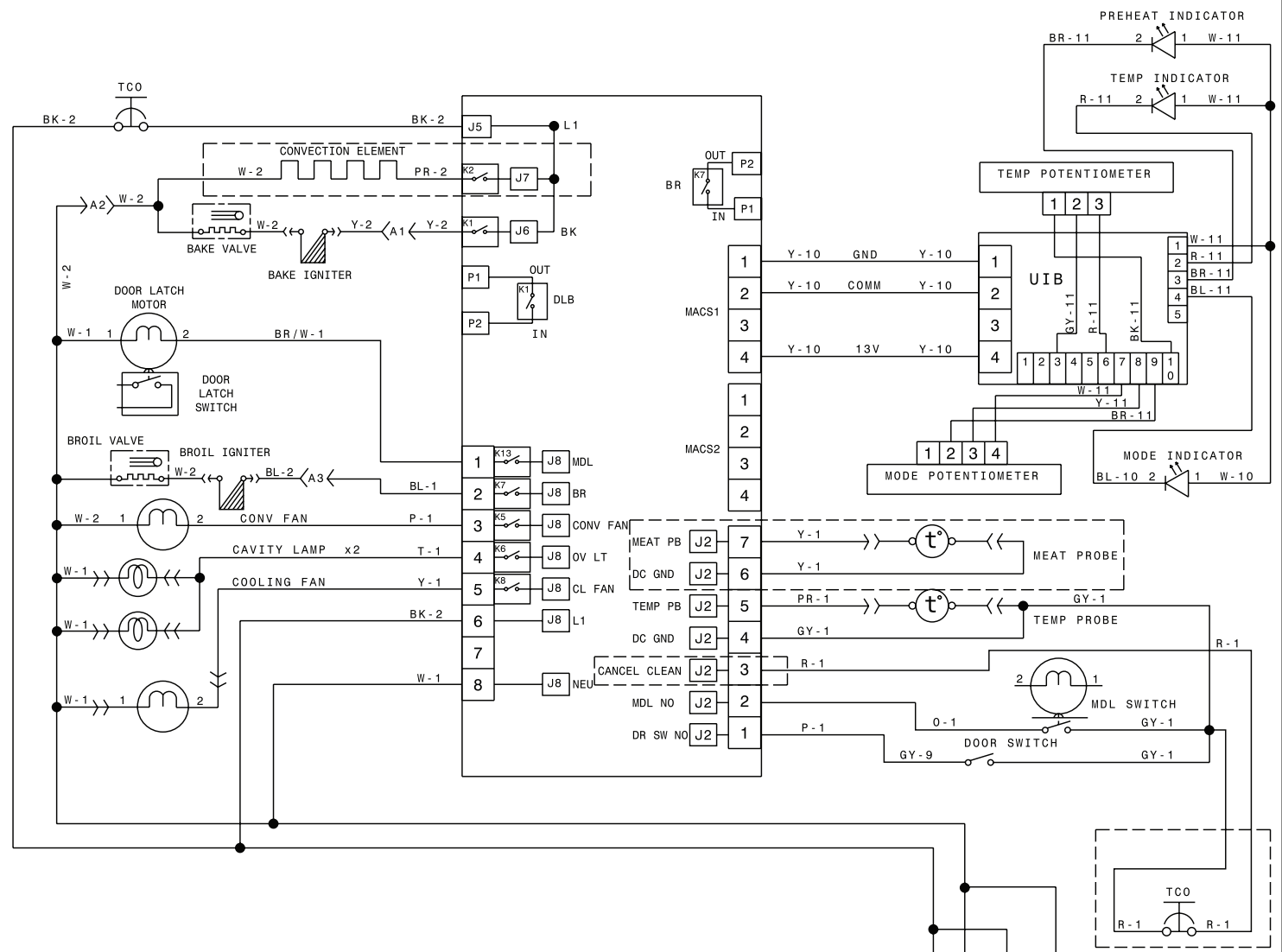

COLOR CODE / CODE COULEUR

- BK = BLACK/NOIR
- BR = BROWN/BRUN
- R = RED/ROUGE
- O = ORANGE/ORANGE
- Y = YELLOW/JAUNE
- G = GREEN/VERT
- BL = BLUE/BLEU
- PR = PURPLE/VIOLET
- GY = GREY/GRIS
- W = WHITE/BLANC
- T = TAN/BRONZER
- P = PINK/ROSE
- BR/W = BROWN/WHITE
BRUN/BLANC
- O/BK = ORANGE/BLACK
ORANGE/NOIR
- PR/O = PURPLE/ORANGE
VIOLET/ORANGE
- GY/BK = GREY/BLACK
GRIS/NOIR
- GY/O = GREY/ORANGE
GRIS/ORANGE
- GY/Y = GREY/YELLOW
GRIS/JAUNE
- GY/R = GREY/RED
GRIS/ROUGE
- GY/BL = GREY/BLUE
GRIS/BLEU

CODE CODE	GAUGE CALIBRE	TEMP.°C	CSA	UL
1	20	150	EXL-B	3321
2	18	150	EXL-B	3321
3	16	150	EXL-B	3321
4	14	150	EXL-B	3321
5	12	150	EXL-B	3321
6	20	125	EXL-A	3173
7	16	125	EXL-A	3173
8	14	125	EXL-A	3173
9	20	200	SF-1	3122
10	22	200	SF-1	10109
11	22	105		1569

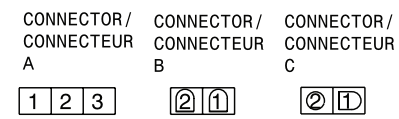

CAUTION: DISCONNECT POWER BEFORE SERVICING UNIT.
 LABEL ALL WIRES PRIOR TO DISCONNECTION WHEN SERVICING CONTROLS.
 WIRINGS ERRORS CAN CAUSE IMPROPER AND DANGEROUS OPERATION.
 VERIFY PROPER OPERATION AFTER SERVICING.

ATTENTION: COUPEZ L'ALIMENTATION AVANT D'EFFECTUER LA REPARATION.
 IDENTIFIEZ TOUS LES FILS AVANT DE LES DEBRANCHER QUAND L'APPAREIL EST HORS SERVICE.
 LES ERREURS DE CONNEXION DE FILS PEUVENT CAUSER UN MAL FONCTIONNEMENT ET UN DANGER D'USAGE DE L'APPAREIL.
 VERIFIEZ LE BON FONCTIONNEMENT DE L'APPAREIL APRES LE SERVICE.

PART NUMBER	REV.
A12802916	A

COOKTOP CIRCUIT

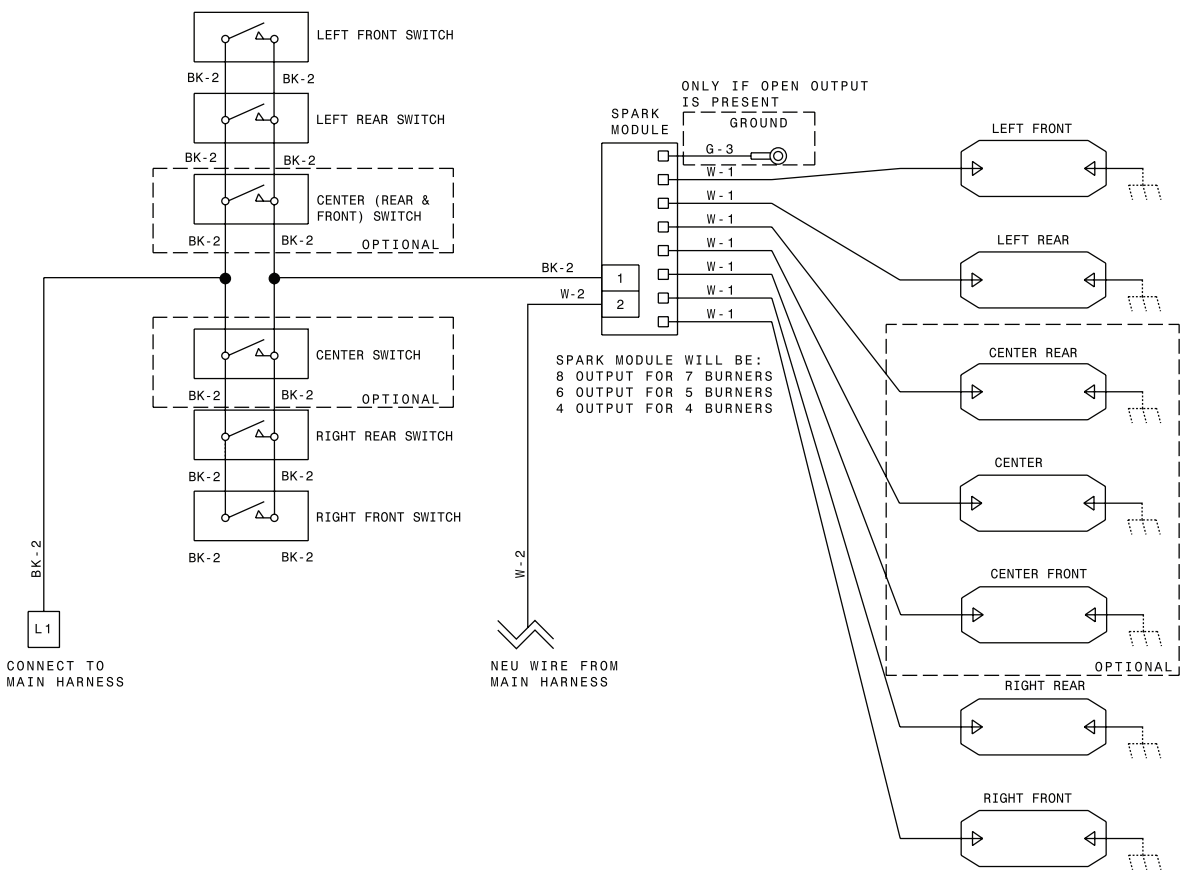

COLOR CODE / CODE COULEUR

- BK = BLACK/NOIR
- BR = BROWN/BRUN
- R = RED/ROUGE
- O = ORANGE/ORANGE
- Y = YELLOW/JAUNE
- G = GREEN/VERT
- BL = BLUE/BLEU
- PR = PURPLE/VIOLET
- GY = GREY/GRIS
- W = WHITE/BLANC
- T = TAN/BRONZER
- P = PINK/ROSE
- BR/W = BROWN/WHITE
BRUN/BLANC
- O/BK = ORANGE/BLACK
ORANGE/NOIR
- PR/O = PURPLE/ORANGE
VIOLET/ORANGE
- GY/BK = GREY/BLACK
GRIS/NOIR
- GY/O = GREY/ORANGE
GRIS/ORANGE
- GY/Y = GREY/YELLOW
GRIS/JAUNE
- GY/R = GREY/RED
GRIS/ROUGE
- GY/BL = GREY/BLUE
GRIS/BLEU

CODE CODE	GAUGE CALIBRE	TEMP.°C	CSA	UL
1	20	200	10202/3304	
2	20	150	EXL-B	3321
3	18	150	EXL-B	3321

CAUTION: DISCONNECT POWER BEFORE SERVICING UNIT.
 LABEL ALL WIRES PRIOR TO DISCONNECTION WHEN SERVICING CONTROLS.
 WIRINGS ERRORS CAN CAUSE IMPROPER AND DANGEROUS OPERATION.
 VERIFY PROPER OPERATION AFTER SERVICING.

ATTENTION: COUPEZ L'ALIMENTATION AVANT D'EFFECTUER LA REPARATION.
 IDENTIFIEZ TOUS LES FILS AVANT DE LES DEBRANCHER QUAND L'APPAREIL EST HORS SERVICE.
 LES ERREURS DE CONNEXION DE FILS PEUVENT CAUSER UN MAL FONCTIONNEMENT ET UN DANGER D'USAGE DE L'APPAREIL.
 VERIFIEZ LE BON FONCTIONNEMENT DE L'APPAREIL APRES LE SERVICE.

PART NUMBER	REV.
A12802917	A

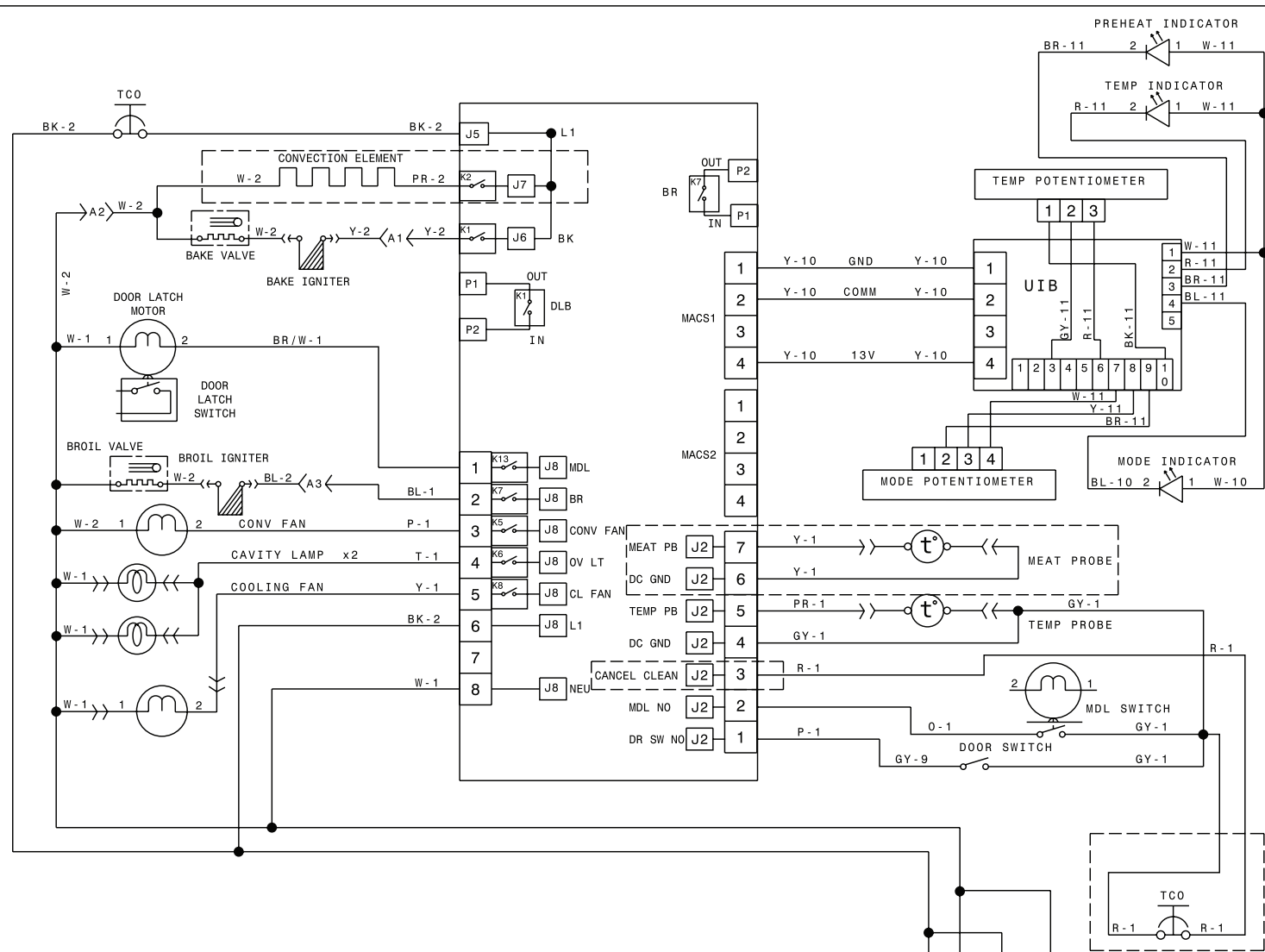

COLOR CODE / CODE COULEUR

- BK = BLACK/NOIR
- BR = BROWN/BRUN
- R = RED/ROUGE
- O = ORANGE/ORANGE
- Y = YELLOW/JAUNE
- G = GREEN/VERT
- BL = BLUE/BLEU
- PR = PURPLE/VIOLET
- GY = GREY/GRIS
- W = WHITE/BLANC
- T = TAN/BRONZER
- P = PINK/ROSE
- BR/W = BROWN/WHITE
BRUN/BLANC
- O/BK = ORANGE/BLACK
ORANGE/NOIR
- PR/O = PURPLE/ORANGE
VIOLET/ORANGE
- GY/BK = GREY/BLACK
GRIS/NOIR
- GY/O = GREY/ORANGE
GRIS/ORANGE
- GY/Y = GREY/YELLOW
GRIS/JAUNE
- GY/R = GREY/RED
GRIS/ROUGE
- GY/BL = GREY/BLUE
GRIS/BLEU

CODE CODE	GAUGE CALIBRE	TEMP.°C	CSA	UL
1	20	150	EXL-B	3321
2	18	150	EXL-B	3321
3	16	150	EXL-B	3321
4	14	150	EXL-B	3321
5	12	150	EXL-B	3321
6	20	125	EXL-A	3173
7	16	125	EXL-A	3173
8	14	125	EXL-A	3173
9	20	200	SF-1	3122
10	22	200	SF-1	10109
11	22	105		1569

CONNECTOR/ CONNECTEUR A	CONNECTOR/ CONNECTEUR B	CONNECTOR/ CONNECTEUR C
1 2 3	2 1	2 1

CAUTION: DISCONNECT POWER BEFORE SERVICING UNIT.
 LABEL ALL WIRES PRIOR TO DISCONNECTION WHEN SERVICING CONTROLS.
 WIRINGS ERRORS CAN CAUSE IMPROPER AND DANGEROUS OPERATION.
 VERIFY PROPER OPERATION AFTER SERVICING.

ATTENTION: COUPEZ L'ALIMENTATION AVANT D'EFFECTUER LA REPARATION.
 IDENTIFIEZ TOUS LES FILS AVANT DE LES DEBRANCHER QUAND L'APPAREIL EST HORS SERVICE.
 LES ERREURS DE CONNEXION DE FILS PEUVENT CAUSER UN MAL FONCTIONNEMENT ET UN DANGER D'USAGE DE L'APPAREIL.
 VERIFIEZ LE BON FONCTIONNEMENT DE L'APPAREIL APRES LE SERVICE.

PART NUMBER
A12802916

REV.
A

COOKTOP CIRCUIT

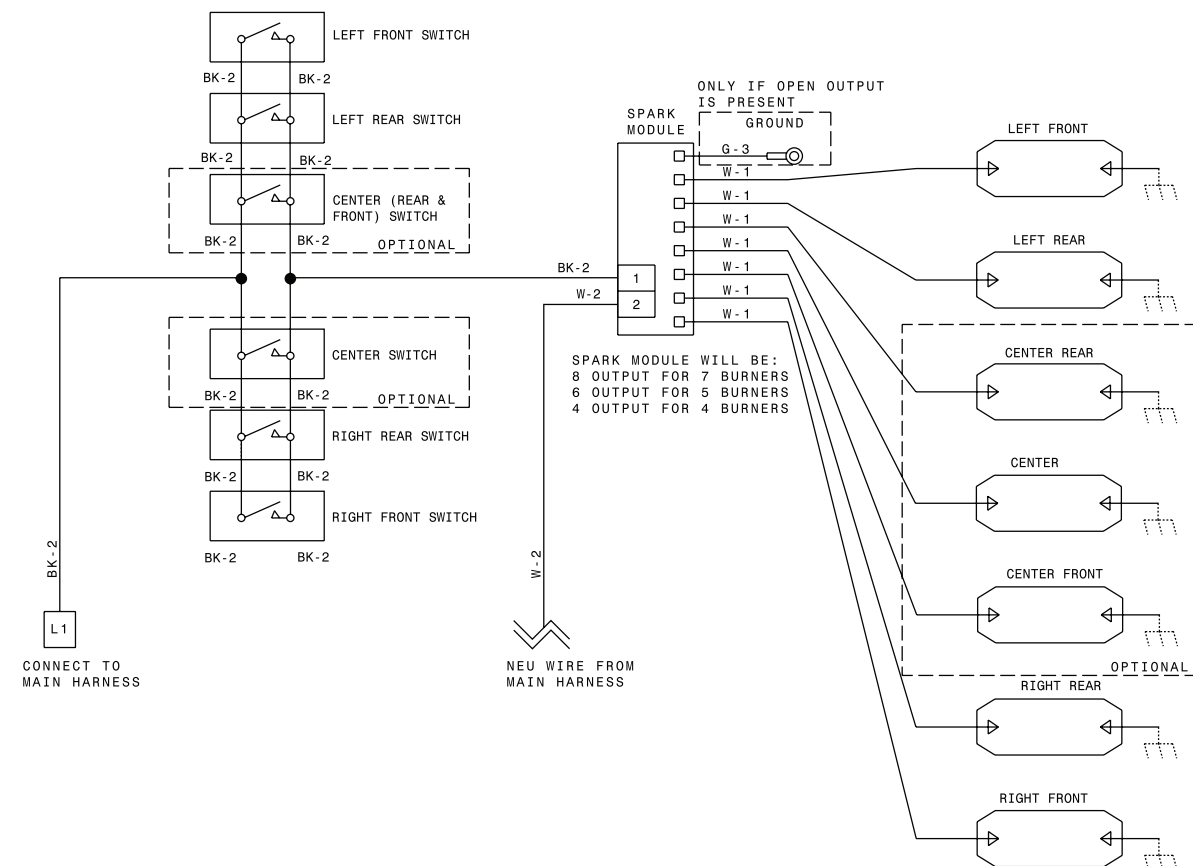

COLOR CODE / CODE COULEUR

- BK = BLACK/NOIR
- BR = BROWN/BRUN
- R = RED/ROUGE
- O = ORANGE/ORANGE
- Y = YELLOW/JAUNE
- G = GREEN/VERT
- BL = BLUE/BLEU
- PR = PURPLE/VIOLET
- GY = GREY/GRIS
- W = WHITE/BLANC
- T = TAN/BRONZER
- P = PINK/ROSE
- BR/W = BROWN/WHITE
BRUN/BLANC
- O/BK = ORANGE/BLACK
ORANGE/NOIR
- PR/O = PURPLE/ORANGE
VIOLET/ORANGE
- GY/BK = GREY/BLACK
GRIS/NOIR
- GY/O = GREY/ORANGE
GRIS/ORANGE
- GY/Y = GREY/YELLOW
GRIS/JAUNE
- GY/R = GREY/RED
GRIS/ROUGE
- GY/BL = GREY/BLUE
GRIS/BLEU

CODE CODE	GAUGE CALIBRE	TEMP.°C	CSA	UL
1	20	200	10202/3304	
2	20	150	EXL-B	3321
3	18	150	EXL-B	3321

CAUTION: DISCONNECT POWER BEFORE SERVICING UNIT.
 LABEL ALL WIRES PRIOR TO DISCONNECTION WHEN SERVICING CONTROLS.
 WIRINGS ERRORS CAN CAUSE IMPROPER AND DANGEROUS OPERATION.
 VERIFY PROPER OPERATION AFTER SERVICING.

ATTENTION: COUPEZ L'ALIMENTATION AVANT D'EFFECTUER LA REPARATION.
 IDENTIFIEZ TOUS LES FILS AVANT DE LES DEBRANCHER QUAND L'APPAREIL EST HORS SERVICE.
 LES ERREURS DE CONNEXION DE FILS PEUVENT CAUSER UN MAL FONCTIONNEMENT ET UN DANGER D'USAGE DE L'APPAREIL.
 VERIFIEZ LE BON FONCTIONNEMENT DE L'APPAREIL APRES LE SERVICE.

PART NUMBER
A12802917

REV.
A