













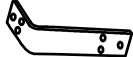

Assembly Instruction

1*1		A*4+1EXT	 M6*22MM
2*1		B*13+1EXT	 M6*20MM
3*1		C*2+1EXT	 M6*16MM
4*4		D*2	
5*1		E*4	
6*1		F*3+1EXT	 M6*20MM
7*1		G*2	 M4 M6

STEP1

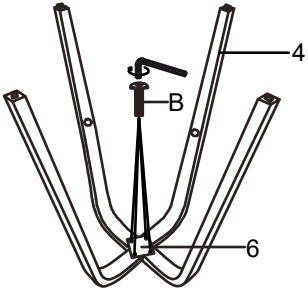

! Keep bolts a little loose

STEP2

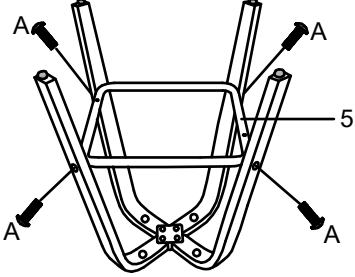

! Keep bolts a little loose

STEP3

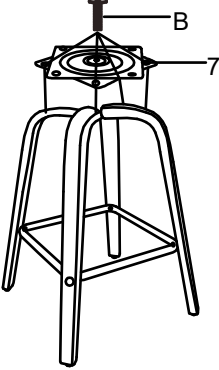

! Place on level surface and tighten all bolts 100%

STEP4

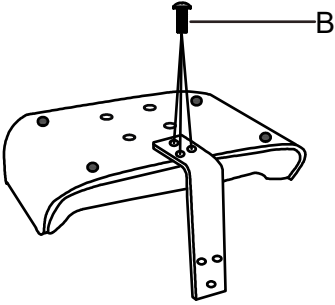

! Keep bolts a little loose

STEP5

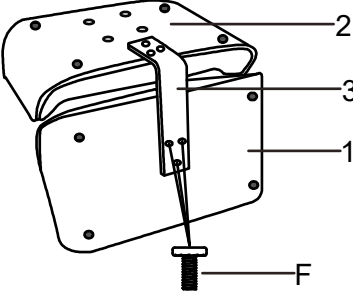

! Make sure the back is straight and tighten all bolts 100%

STEP6

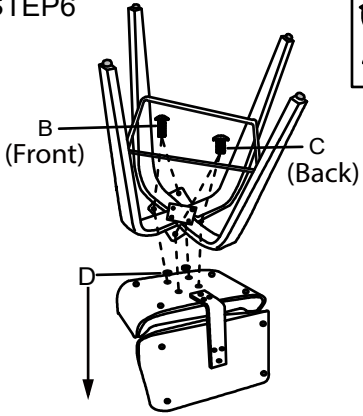

! Attach Plastic Rings (D) to Front bolts (B).

STEP7

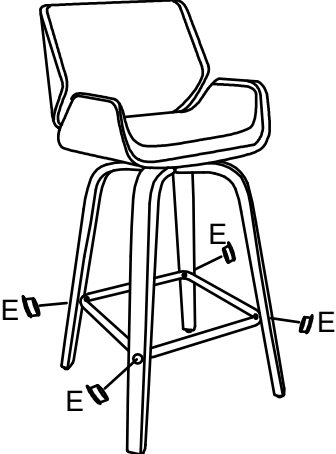

STEP8



! Please adjust the rotating floor protectors if the legs are uneven.