

*ASSEMBLY INSTRUCTIONS
COASTER FINE FURNITURE*



Fine Furniture for every stage of life

706458
Coffee Table

ITEM: 706458



ASSEMBLY INSTRUCTIONS

ASSEMBLY TIPS:

1. Remove hardware from box and sort by size.
2. Please check to see that all hardware and parts are present prior to start of assembly.
3. Please follow attached instructions in the same sequence as numbered to assure fast & easy assembly.



WARNING!

1. Don't attempt to repair or modify parts that are broken or defective. Please contact the store immediately.
2. This product is for home use only and not intended for commercial establishments.



ASSEMBLY TIME

15 MINUTES

PARTS IDENTIFICATION

A	TOP		1PC
B	SHELF		1PC
C	LEG		3PCS

HARDWARE IDENTIFICATION

1	ALLEN WRENCH (M4 X 60MM - RBW)		1PC
2	BOLT (M6 X 90MM - RBW)		6PCS
3	LOCK WASHER (M6 X 13MM - RBW)		6PCS
4	FLAT WASHER (M6 X 19MM - RBW)		6PCS

ITEM: **706458**

ASSEMBLY INSTRUCTIONS



STEP 1

Attention! Don't tighten the screws until the shelf is installed.

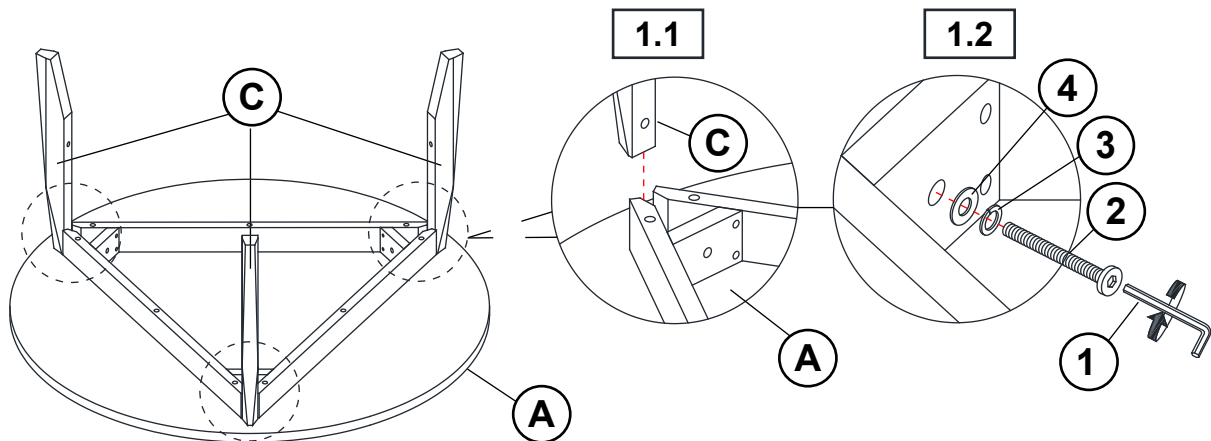

STEP 2

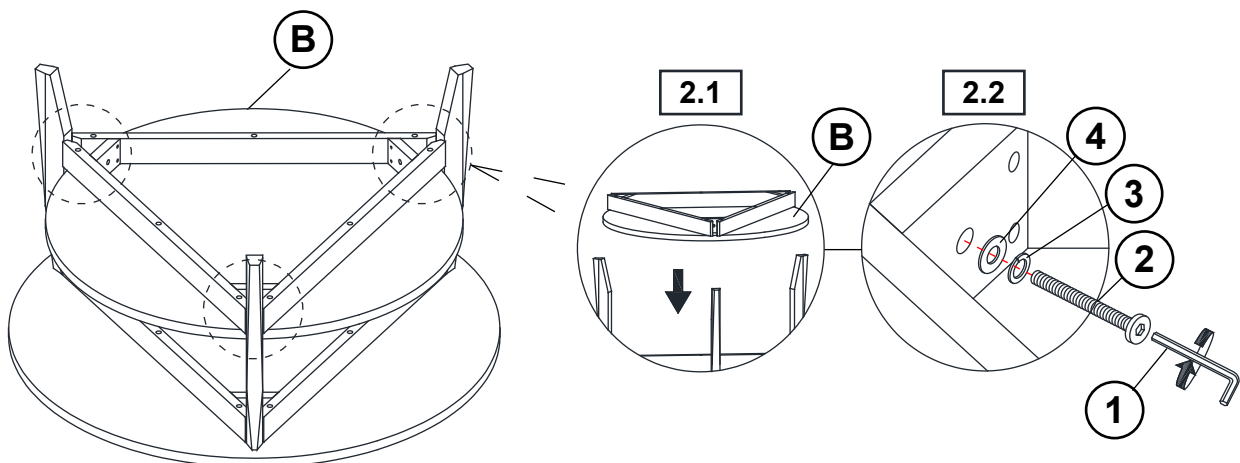

ITEM: **706458**

ASSEMBLY INSTRUCTIONS



STEP 3

Fully tighten the screws in this step.

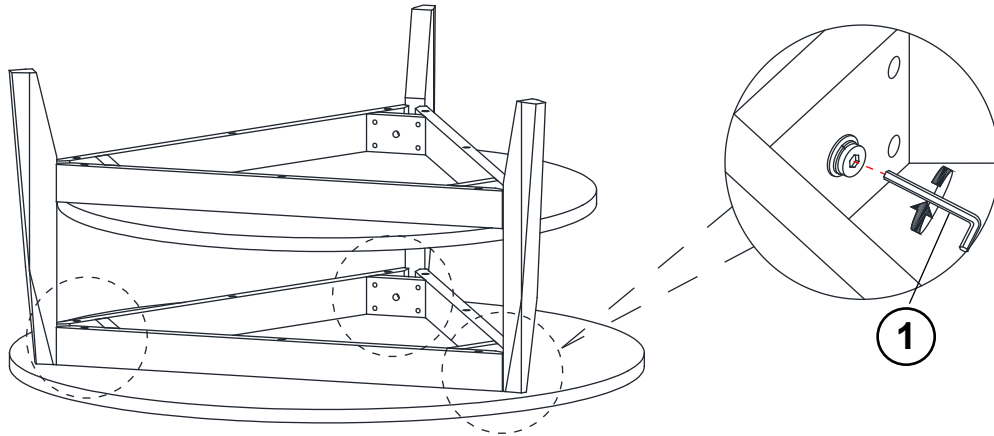

STEP 4 **COMPLETE**

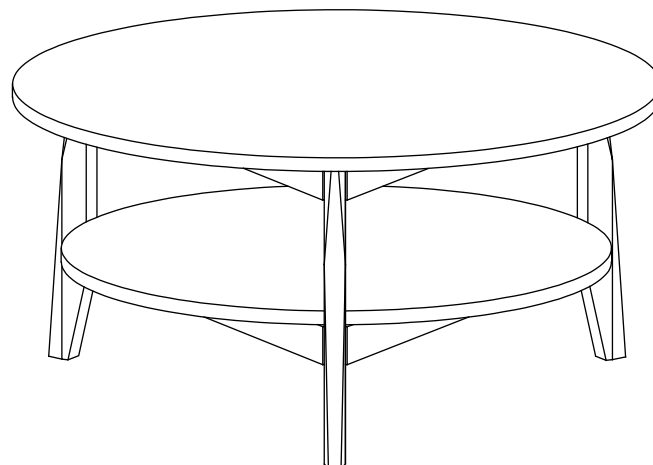

ITEM: 706448

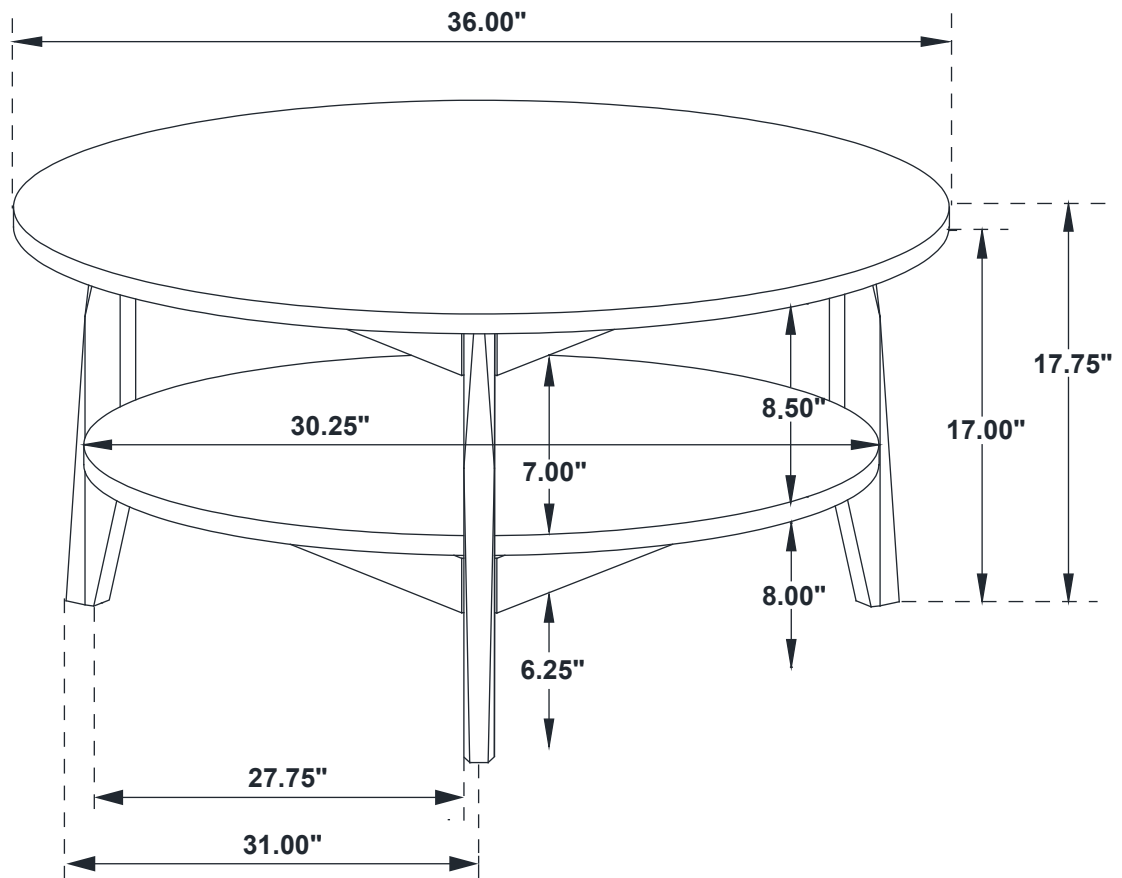

Note: Dimension tolerance $\pm 5\%$