

FREEMOTION[®]

ADJUSTABLE BENCH

Model No. EF203.0

Serial No. _____

Write the serial number in the space above for reference.

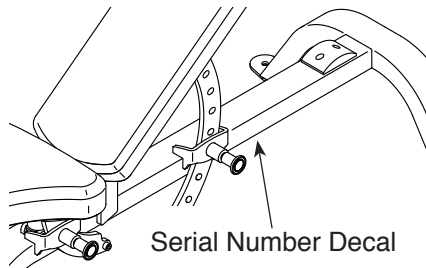

OWNER'S MANUAL

QUESTIONS?

If you have questions, or if parts are damaged or missing, please see **HOW TO CONTACT CUSTOMER CARE** on the back cover of this manual.

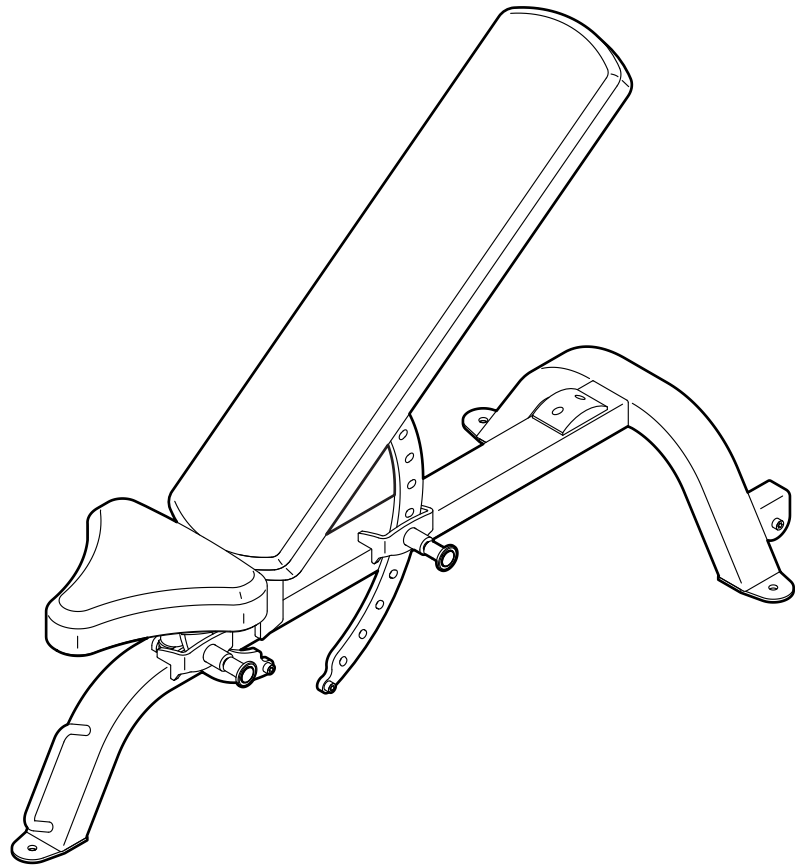

⚠ CAUTION

Read all precautions and instructions in this manual before using this equipment. Keep this manual for future reference.

TABLE OF CONTENTS

WARNING DECAL PLACEMENT	2
IMPORTANT PRECAUTIONS	3
BEFORE YOU BEGIN	4
ASSEMBLY AND ADJUSTMENT	5
MAINTENANCE AND TROUBLESHOOTING	6
PART LIST/EXPLODED DRAWING	7
HOW TO CONTACT CUSTOMER CARE	Back Cover
LIMITED WARRANTY	Back Cover

WARNING DECAL PLACEMENT

This drawing shows the location(s) of the warning decal(s). **If a decal is missing or illegible, see the back cover of this manual and request a free replacement decal. Apply the decal in the location shown.** Note: The decal(s) may not be shown at actual size.

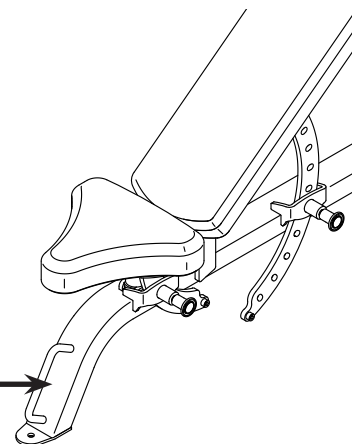
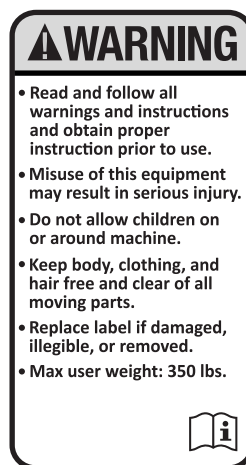

IMPORTANT PRECAUTIONS

⚠️ WARNING: To reduce the risk of serious injury, read all important precautions and instructions in this manual and all warnings on your strength equipment before using your strength equipment. Freemotion Fitness assumes no responsibility for personal injury or property damage sustained by or through the use of this product.

1. It is the responsibility of the owner to ensure that all users of the strength equipment are adequately informed of all precautions, have read and understood all warning and caution labels, and are informed of how to use the strength equipment properly.
2. All users of the strength equipment should be instructed to report any injury or strength equipment irregularity to facility staff immediately.
3. Before beginning any exercise program, consult your physician. This is especially important for persons over age 35 or persons with pre-existing health problems.
4. Use the strength equipment only on a level surface. Cover the floor beneath the strength equipment to protect the floor.
5. It is the responsibility of the owner to ensure that there is enough space around the strength equipment for the intended exercise.
6. Using the anchor holes (see page 4), anchor the strength equipment to the floor to provide maximum stability.
7. Make sure that all parts are properly tightened before each use of the strength equipment.
8. Keep children under age 13 and pets away from the strength equipment at all times.
9. The strength equipment is designed to support a maximum user weight of 350 lbs. (159 kg) and a maximum total weight of 795 lbs. (361 kg). Do not use the strength equipment with more than 445 lbs. (202 kg) of weight. Note: The strength equipment does not include weights.
10. Always wear athletic shoes for foot protection while exercising.
11. Keep hands and feet away from moving parts. Do not lean on or rest your hands on the strength equipment while it is in use.
12. Use the strength equipment only as described in this manual.
13. Over exercising may result in serious injury or death. If you feel faint, if you become short of breath, or if you experience pain while exercising, stop immediately and cool down.

BEFORE YOU BEGIN

Thank you for selecting the new FREEMOTION® ADJUSTABLE BENCH strength equipment. The ADJUSTABLE BENCH is designed to help you develop the major muscle groups of your upper body. Whether your goal is to tone your body or build dramatic muscle size and strength, the ADJUSTABLE BENCH will help you to achieve the specific results you want.

For your benefit, read this manual carefully before you use the strength equipment. If you have

questions after reading this manual, please see the back cover of this manual. To help us assist you, note the product model number and serial number before contacting us. The model number and the location of the serial number decal are shown on the front cover of this manual.

Before reading further, please familiarize yourself with the parts that are labeled in the drawing below.

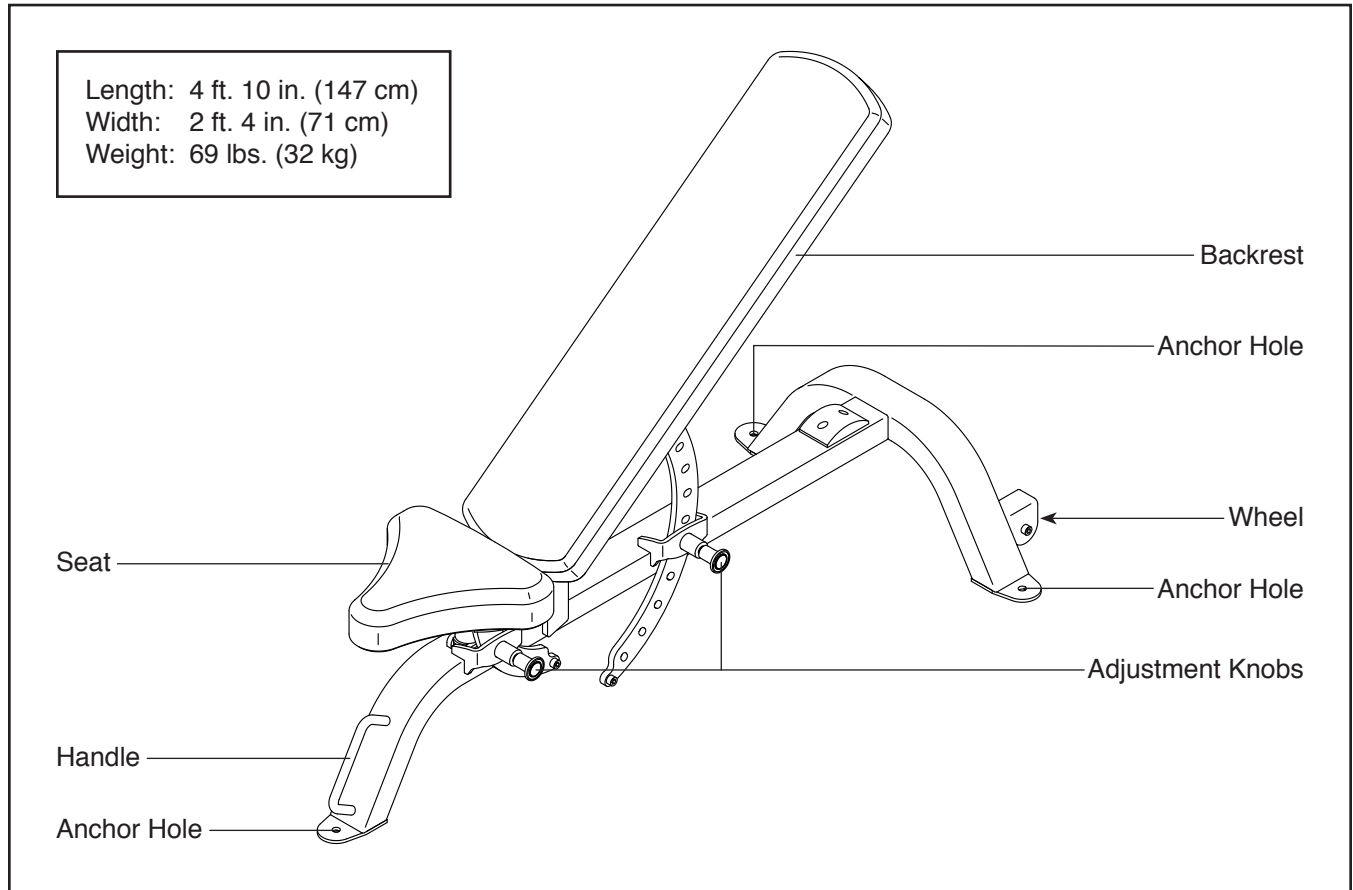

ASSEMBLY AND ADJUSTMENT

Place all parts of the strength equipment in a cleared area and remove the packing materials; **do not dispose of the packing materials until assembly is completed. Assembly requires a metric hex key (not included).**

1. Attach the Backrest (14) to the Backrest Frame (2) with an M8 x 25mm Screw (22) and an M8 x 80mm Screw (23); **to avoid damaging the Backrest, tighten the Screws only until the Backrest does not move or feel loose.**

To adjust the angle of the Backrest (14), hold the Backrest with one hand and pull the indicated Adjustment Knob (16) with your other hand. Pivot the Backrest to the desired angle, and re-engage the Adjustment Knob into the Large Adjustment Bracket (4).

⚠ WARNING: Always hold the Backrest (14) before pulling the Adjustment Knob (16); the Backrest can fall with great force.

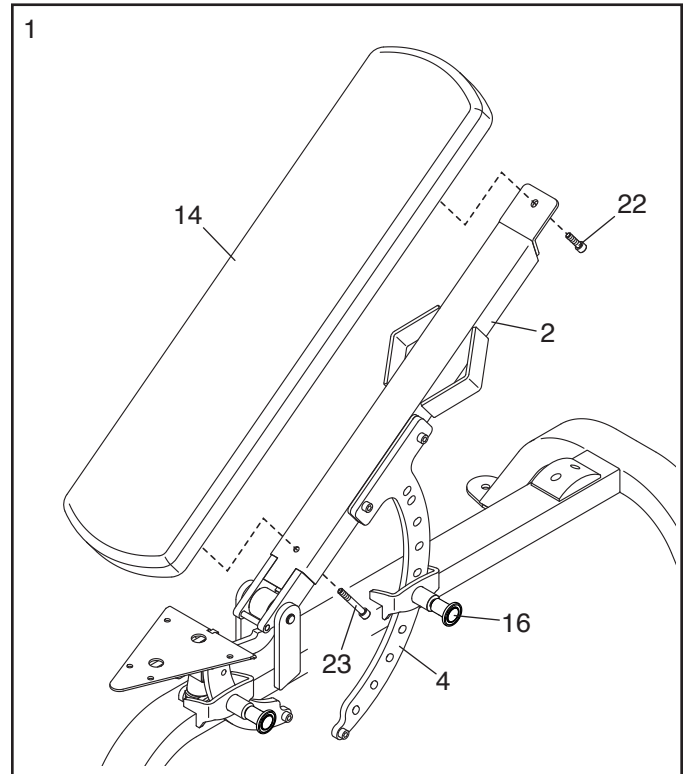

2. Attach the Seat (13) to the Seat Frame (3) with four M8 x 25mm Screws (22); **to avoid damaging the Seat, tighten the Screws only until the Seat does not move or feel loose.**

To adjust the angle of the Seat (13), hold the Seat with one hand and pull the indicated Adjustment Knob (16) with your other hand. Pivot the Seat to the desired angle, and re-engage the Adjustment Knob into the Small Adjustment Bracket (5).

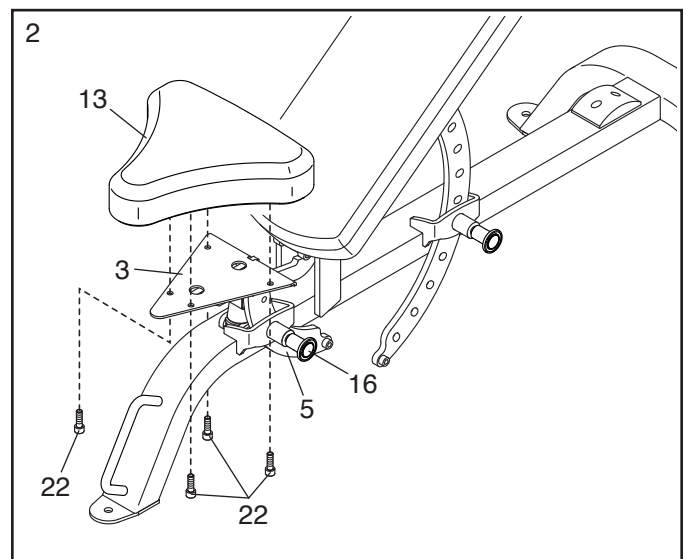

3. **Make sure that all parts of the strength equipment are properly tightened.**

To move the strength equipment, first lift the handle beneath the seat until the wheels touch the floor. Carefully push the strength equipment to the desired location, and then lower it. To protect the floor or carpet from damage, place a mat beneath the strength equipment.

MAINTENANCE AND TROUBLESHOOTING

For optimal performance of the strength equipment and to reduce the chances of injury to users, you must perform preventive maintenance on a regular basis. Instruct all personnel to perform the procedures described in this section. Personnel must also record and report any accident. To maintain the strength equipment's warranty, use only FREEMOTION parts for repair or replacement. If there are any questions or concerns, see HOW TO CONTACT CUSTOMER CARE on the back cover of this manual.

DAILY MAINTENANCE

General Cleaning

Clean the strength equipment using a soft cloth dampened with a light solution of mild soap and warm water. If necessary, use a soft bristle brush with the cleaning solution.

Then, rinse the area thoroughly using a soft cloth dampened with clean water, and thoroughly dry it.

Difficult Stains

Spray the stain with a non-abrasive household cleaner such as FORMULA 409® cleaner, SIMPLE GREEN®, or a similar product. Rub the stained area gently and let the cleaning solution sit for a few minutes.

Then, rinse the area thoroughly using a soft cloth dampened with clean water, and thoroughly dry it.

Repeat these steps, if necessary, using a soft bristle brush.

Optional Method for Difficult Stains

Rub the stained area gently using a soft cloth dampened with rubbing alcohol.

Then, rinse the area thoroughly using a soft cloth dampened with clean water, and thoroughly dry it.

CAUTION: When using any cleaning product, try it first in an unnoticeable place to ensure that there is no damage to the material. Follow the directions and the safety precautions of the manufacturer of each cleaning product used. Freemotion Fitness and its vendors cannot be held liable for damage or injuries resulting from the use or misuse of cleaning products.

IMPORTANT: Do not use abrasive cleaners, which may scratch the strength equipment. Strong cleaners and abrasives will damage decals; use caution around decals. Do not use solvents such as lacquer thinner, kerosene, gasoline, or similar liquids.

WEEKLY MAINTENANCE

Hardware

Check all nuts and bolts, and tighten them if necessary. **IMPORTANT:** All FREEMOTION cushions have dense plywood supports with tee-nuts that are used to bolt the cushions to the strength equipment. Because the tee-nuts are held by the plywood, they will not withstand the torque that standard nuts and bolts will. When tightening the bolts securing a cushion, turn them only until they are snug and the cushion does not move or feel loose. Overtightening may strip the tee-nuts from the plywood and make it impossible to remove the cushion in the future.

Wheels

The wheels should roll easily. Tighten or replace the wheels if necessary.

Adjustment Knob

If an adjustment knob (A) sticks, it should be relubricated. Unscrew the knob and apply a light coating of lithium grease. Then, reassemble the knob as shown below. If the adjustment knob still does not function properly, the spring (B) may need to be replaced. To order a spring, see HOW TO CONTACT CUSTOMER CARE on the back cover of this manual.

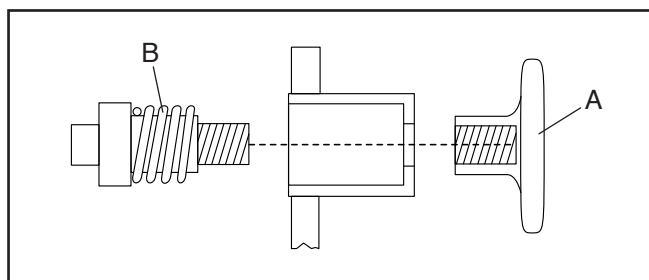

PART LIST/EXPLODED DRAWING

Model No. EF203.0 R0419A

Key No.	Qty.	Description	Key No.	Qty.	Description
1	1	Main Frame	20	2	Bearing
2	1	Backrest Frame	21	1	M6 x 25mm Button Screw
3	1	Seat Frame	22	5	M8 x 25mm Screw
4	1	Large Adjustment Bracket	23	1	M8 x 80mm Screw
5	1	Small Adjustment Bracket	24	2	M10 x 16mm Screw
6	1	Bracket Plate	25	2	M10 x 65mm Bolt
7	1	Seat Frame Shaft	26	2	M10 x 80mm Bolt
8	2	Adjustment Pin	27	2	M10 x 110mm Bolt
9	6	M10 Locknut	28	2	M6 x 15mm Button Screw
10	2	M10 Washer	*	-	Owner's Manual
11	2	Wheel			
12	4	Nylon Spacer			
13	1	Seat			
14	1	Backrest			
15	2	Snap Ring			
16	2	Adjustment Knob			
17	2	Spring			
18	1	Backrest Bumper			
19	1	Seat Bumper			

Note: Specifications are subject to change without notice. For information about ordering replacement parts, see the back cover of this manual. *These parts are not illustrated.

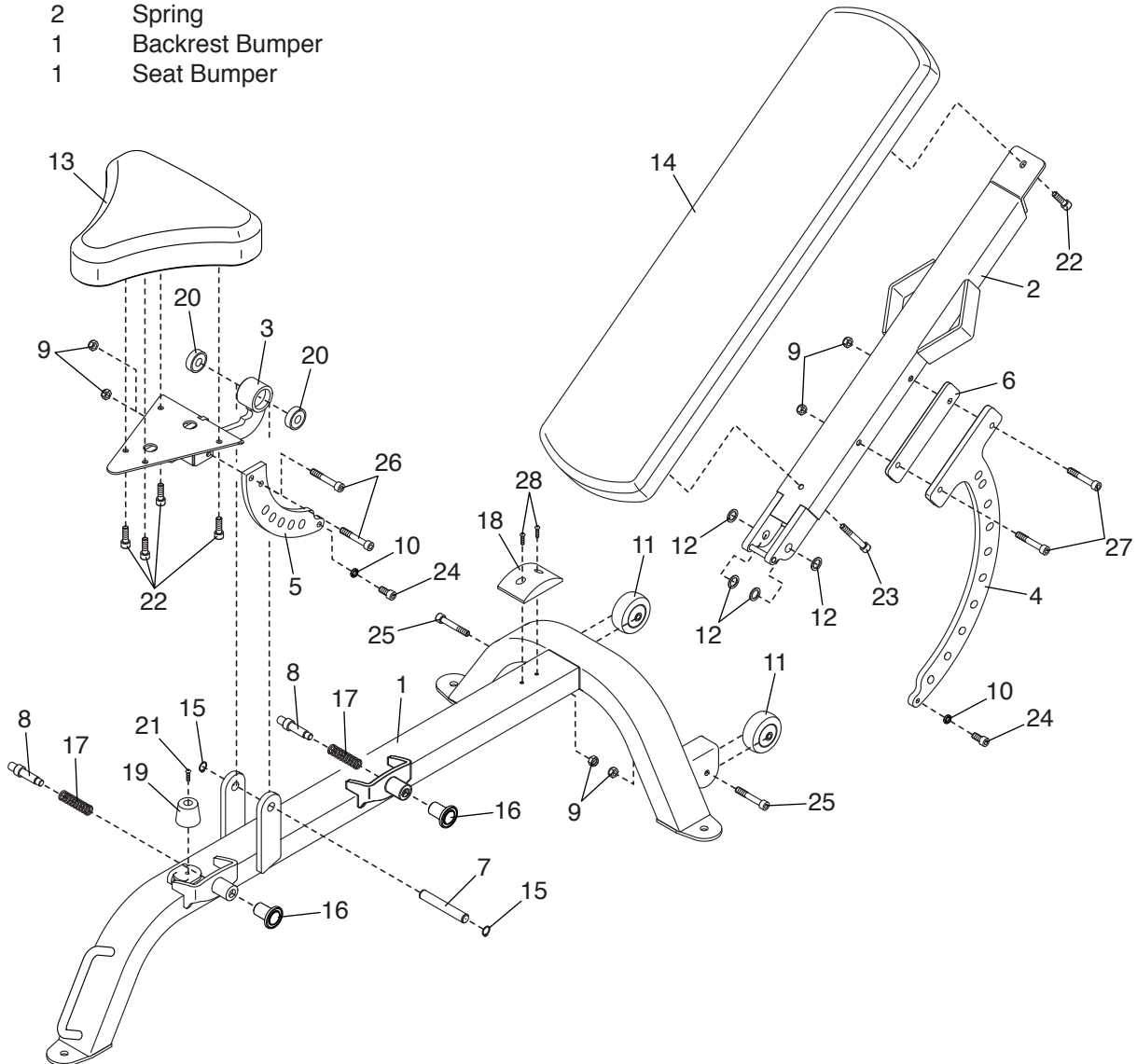

HOW TO CONTACT CUSTOMER CARE

If you have questions after reading this manual, or if parts are damaged or missing, please contact Customer Care at one of the phone numbers or addresses listed below. **Please note the model number, serial number, and name of the product (see the front cover of this manual) before contacting Customer Care. If you are ordering replacement parts, please also note the key number and description of each part (see the PART LIST and the EXPLODED DRAWING near the end of this manual).**

In the United States

Call: 1-800-201-2109, Mon.–Fri. 6 a.m.–6 p.m. MT

Email: customercare@freemotionfitness.com

Write:

Freemotion Fitness
1500 South 1000 West
Logan, UT 84321-9813
United States

Outside the United States

Call: 001-800-527-5417 or 001-435-786-3521,

Mon.–Fri. 6 a.m.–3 p.m. USA Mountain Time

Email: intlcustomercare@freemotionfitness.com

LIMITED WARRANTY

WARRANTY PERIODS AND COVERAGE

Freemotion Fitness warrants this product to be free from defects in workmanship and material under normal use and service conditions. Parts and labor are warranted for one (1) year, unless otherwise specified on the invoice.

The warranty period commences on the invoice date of purchase. Any parts repaired or replaced during this warranty period will be warranted for the remainder of the original warranty period.

CONDITIONS AND LIMITATIONS

The following will void the warranty on this product:

1. This warranty applies only to the original owner and is non-transferable.
2. The labor warranty applies only to products sold in the US and Canada. Contact your authorized Freemotion Fitness dealer for details on labor coverage in your country.
3. Any misuse, abuse, or improper service.
4. Users who weight more than the maximum user weight listed in this manual. Note: This product may not have a maximum user weight.
5. Damage caused by moving the product or improper storage including moving or storing the product on its side.
6. Use or storage of the product outdoors or in high-humidity environments including spa and pool areas.
7. Damage caused by improper wiring or insufficient electrical current. Note: This product may not have wiring.

This warranty shall not apply to the following:

1. Cosmetic items including grips, decals, and labels.

2. Pick-up and delivery or freight charges involved with a repair.
3. Any problem as a result of improper assembly or delivery.

WHAT TO DO IF SERVICE IS REQUIRED

Freemotion Fitness warranty service may be obtained by contacting the authorized dealer from which you purchased this product. Make sure to retain your original invoice and serial number information. If this product experiences a failure under the warranty terms set forth, Freemotion Fitness shall provide at their option either repair, replacement, or refund of the purchase price. Freemotion Fitness compensates service providers for warranty trips within their service area. You may be charged additionally for service calls beyond this service area.

Freemotion Fitness is not responsible or liable for indirect, special, or consequential damages arising out of or in connection with the use or performance of the product; damages with respect to any economic loss, loss of property, loss of revenues or profits, loss of enjoyment or use, or cost of removal or installation; or other consequential damages. Some regions do not allow the exclusion or limitation of consequential damages. Accordingly, the above limitation may not apply to you. This warranty gives you specific rights, and you may have other rights that vary from region to region.

TO CONTACT FREEMOTION FITNESS

See HOW TO CONTACT CUSTOMER CARE above.