

FREEMOTION®

MULTI-PLANE SHOULDER

Model No. G601.0

Serial No. _____

Write the serial number in the space above for reference.

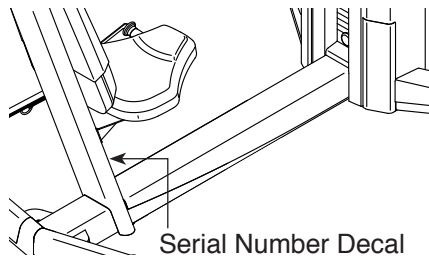

OWNER'S MANUAL

QUESTIONS?

If you have questions, or if parts are damaged or missing, please see **HOW TO CONTACT CUSTOMER CARE** on the back cover of this manual.

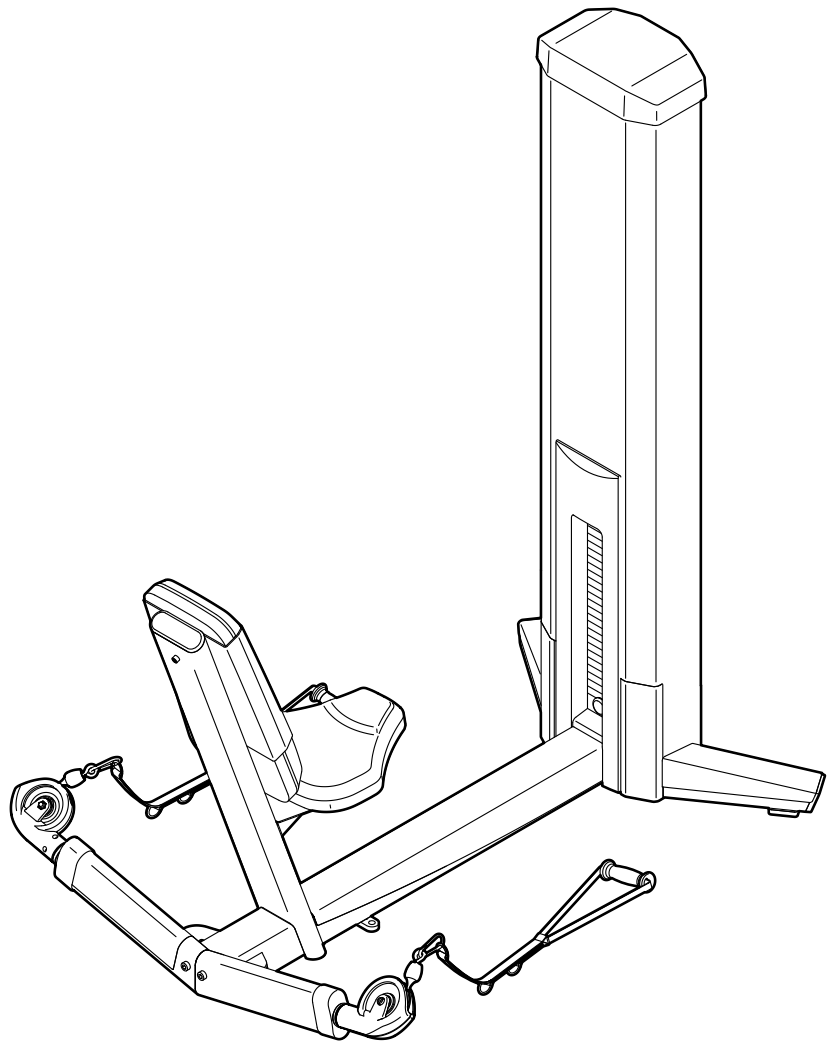

⚠ CAUTION

Read all precautions and instructions in this manual before using this equipment. Keep this manual for future reference.

TABLE OF CONTENTS

IMPORTANT PRECAUTIONS.....	3
WARNING DECAL PLACEMENT.....	4
BEFORE YOU BEGIN.....	5
ADJUSTMENTS.....	6
MAINTENANCE AND TROUBLESHOOTING.....	7
CABLE DIAGRAM.....	11
PART LIST.....	13
EXPLODED DRAWING.....	14
HOW TO CONTACT CUSTOMER CARE.....	Back Cover
LIMITED WARRANTY.....	Back Cover

FREEMOTION is a registered trademark of ICON Health & Fitness, Inc. FORMULA 409 is a registered trademark of The Clorox Company. SIMPLE GREEN is a registered trademark of Sunshine Makers, Inc. TEFLON is a registered trademark of E. I. du Pont de Nemours and Company.

IMPORTANT PRECAUTIONS

⚠️ WARNING: To reduce the risk of serious injury, read all important precautions and instructions in this manual and all warnings on your strength equipment before using your strength equipment. Freemotion Fitness assumes no responsibility for personal injury or property damage sustained by or through the use of this product.

1. It is the responsibility of the owner to ensure that all users of the strength equipment are adequately informed of all precautions, have read and understood all warning and caution labels, and are informed of how to use the strength equipment properly.
2. Before beginning any exercise program, consult your physician. This is especially important for persons over age 35 or persons with pre-existing health problems.
3. Use the strength equipment only as described in this manual.
4. It is the responsibility of the owner to ensure that there is enough space around the strength equipment for the intended exercise.
5. Use the strength equipment only on a level surface. Cover the floor beneath the strength equipment to protect the floor.
6. Using the anchor holes (see page 5), anchor the strength equipment to the floor to provide maximum stability.
7. All users of the strength equipment should be instructed to report any injury or strength equipment irregularity to facility staff immediately.
8. Keep children under age 13 and pets away from the strength equipment at all times.
9. The strength equipment is designed to support a maximum user weight of 350 lbs. (159 kg).
10. Always wear athletic shoes for foot protection while exercising.
11. Keep hands and feet away from moving parts. Do not lean on or rest your hands on the strength equipment while it is in use.
12. Make sure that the weight pin is completely inserted into one of the weight plates.
13. Make sure that the handles are attached securely before each use of the strength equipment.
14. Check each cable, cable connection, and pulley before each use of the strength equipment. Make sure that all parts are properly tightened. Replace any worn parts immediately.
15. Make sure that each cable remains on the pulleys at all times. If a cable binds while you are exercising, stop immediately and make sure that the cable is on the pulleys and that nothing is interfering with the cable or the pulleys.
16. Over exercising may result in serious injury or death. If you feel faint, if you become short of breath, or if you experience pain while exercising, stop immediately and cool down.

WARNING DECAL PLACEMENT

This drawing shows the location(s) of the warning decal(s). **If a decal is missing or illegible, see the back cover of this manual and request a free replacement decal. Apply the decal in the location shown.** Note: The decal(s) may not be shown at actual size.

Decal 1 (inside access cover)

Decal 1

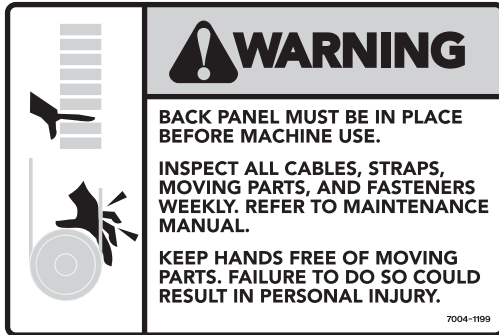



Decal 3

Decal 2

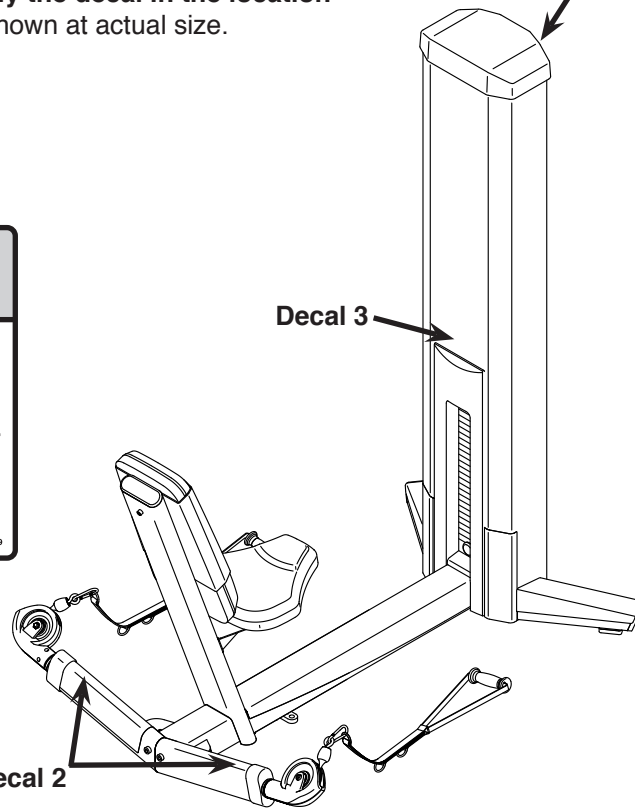
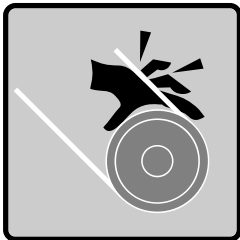
Decal 2



Decal 3 (Part of the instruction placard)

WARNING	
 <ul style="list-style-type: none"> Follow all warnings & instructions & obtain proper instruction prior to use. Do not allow children on machines; teenagers must be supervised by a knowledgeable adult. 	<ul style="list-style-type: none"> The weight pin must be completely inserted. NEVER pin the weight stack in an elevated position or use the machine in this condition.
 <ul style="list-style-type: none"> Obtain a medical exam before beginning. Keep body & clothing clear of moving parts. Inspect all cables, straps & their connections. Do not use if any component is damaged. Keep hands free of moving parts. Failure to do so could result in personal injury. 	<ul style="list-style-type: none"> Do not use dumbbells or other means to incrementally increase the weight resistance, other than those provided by the manufacturer. Maximum user weight is 350 lbs. Do not remove this label. REPLACE IF DAMAGED.
	

BEFORE YOU BEGIN

Thank you for selecting the FREEMOTION® MULTI-PLANE SHOULDER strength equipment. With unrestricted motion, you can work your body's muscle groups together—the same way you do naturally—and train more specifically and efficiently.

For your benefit, read this manual carefully before using the strength equipment. If you have questions after reading this manual, please see the back cover

of this manual. To help us assist you, note the product model number and serial number before contacting us. The model number and the location of the serial number decal are shown on the front cover of this manual.

Before reading further, please review the drawing below and familiarize yourself with the parts that are labeled.

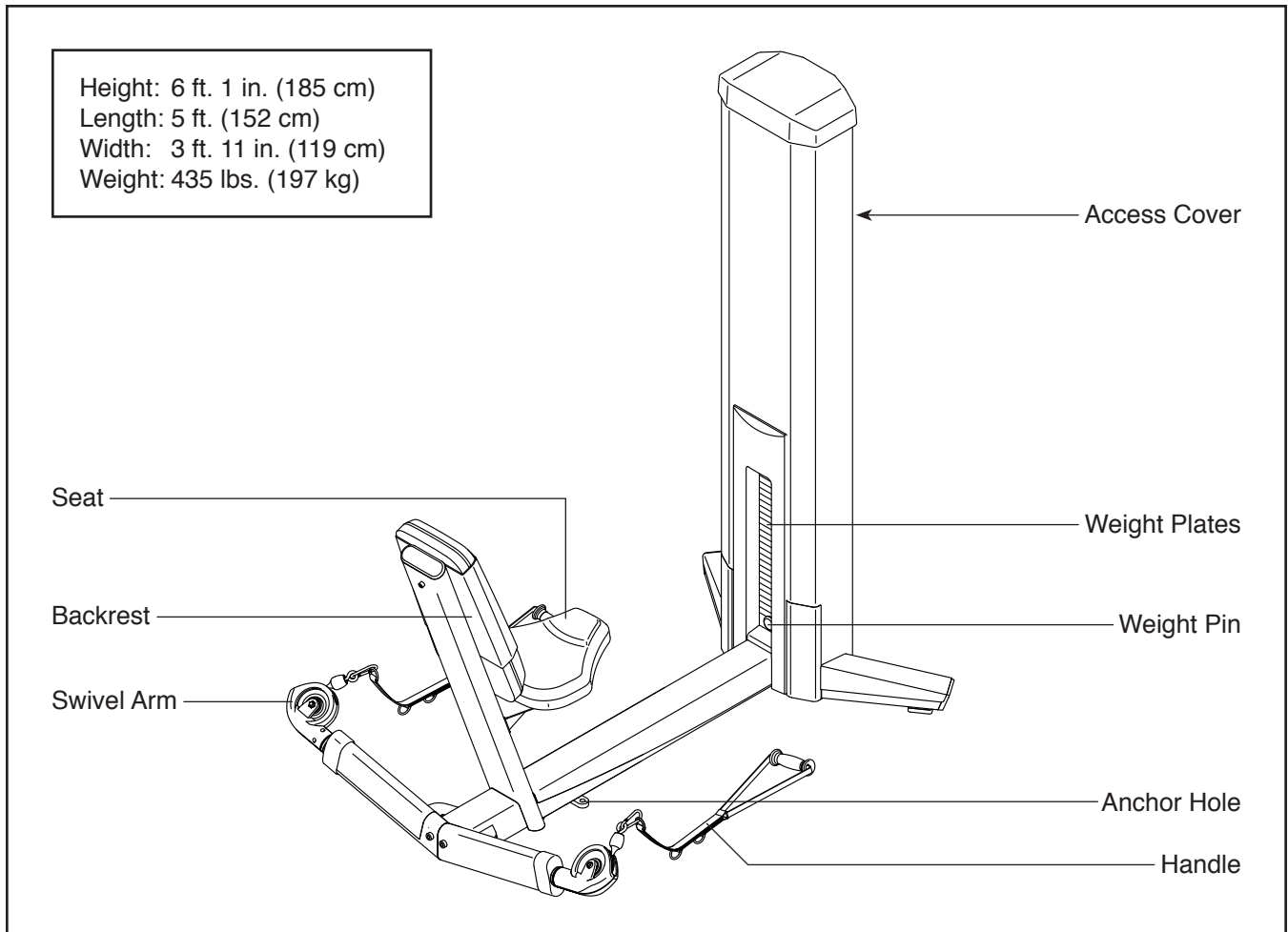

ADJUSTMENTS

This section explains how to adjust the strength equipment. **Make sure all parts are properly tightened each time the strength equipment is used. Replace any worn parts immediately.**

ADJUSTING THE RESISTANCE

To change the amount of resistance during your workout, pull the weight pin (A), slide the weight pin upward or downward to the desired weight plate (B), and then insert the weight pin fully into the weight plate; **make sure that the weight pin is fully inserted.**

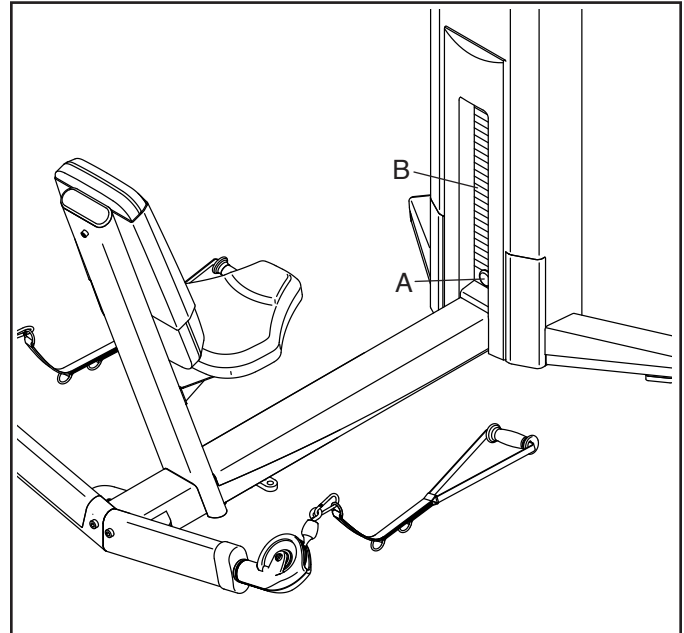

ADJUSTING THE HANDLES

The handles (C) have D-rings (D) that allow you to adjust the positions of the handles. Depending on the exercise that you are performing, attach a cable clip (E) to the appropriate D-ring on each handle.

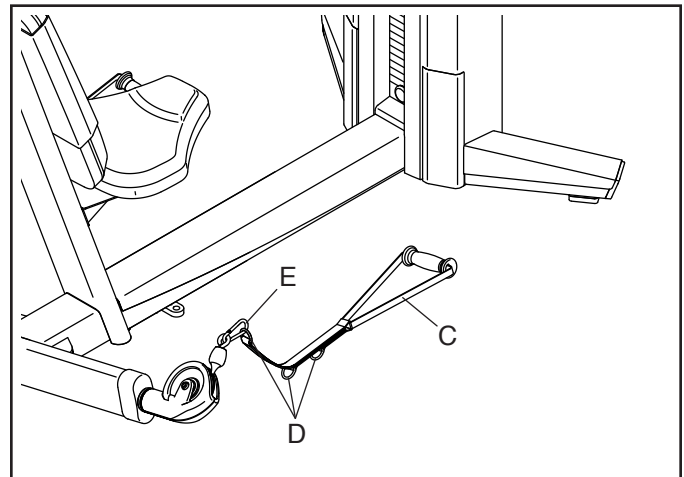

MAINTENANCE AND TROUBLESHOOTING

For optimal performance of the strength equipment and to reduce the chances of injury to users, you must perform preventive maintenance on a regular basis. Instruct all personnel to perform the procedures described in this section. Personnel must also record and report any accident. To maintain the strength equipment's warranty, use only FREEMOTION parts for repair or replacement. If there are any questions or concerns, see HOW TO CONTACT CUSTOMER CARE on the back cover of this manual.

DAILY MAINTENANCE

Upholstery and Frame—General Cleaning

1. Clean the strength equipment using a soft cloth dampened with a light solution of mild soap and warm water. If necessary, use a soft bristle brush with the cleaning solution.
2. Rinse the area thoroughly using a soft cloth dampened with clean water. Dry thoroughly.

Upholstery—Difficult Stains

1. Spray the stain with a non-abrasive household cleaner such as FORMULA 409® cleaner, SIMPLE GREEN®, or a similar product. Rub the stained area gently and let the cleaning solution sit for a few minutes.
2. Rinse the area thoroughly using a soft cloth dampened with clean water. Dry thoroughly.
3. Repeat these steps if necessary using a soft bristle brush.

Optional Method for Difficult Stains

1. Rub the stained area gently using a soft cloth dampened with rubbing alcohol.
2. Rinse the area thoroughly using a soft cloth dampened with clean water. Dry thoroughly.

CAUTION: When using any cleaning product, try it first in an unnoticeable place to ensure that there is no damage to the material. Follow the directions and the safety precautions of the manufacturer of each cleaning product used. Freemotion Fitness and its vendors cannot be held liable for damage or injuries resulting from the use or misuse of cleaning products.

IMPORTANT: Do not use abrasive cleaners, which may scratch the strength equipment. Strong cleaners and abrasives will damage decals; use caution around decals. Do not use solvents such as lacquer thinner, kerosene, gasoline, or similar liquids.

WEEKLY MAINTENANCE

Hardware

Check all nuts and bolts and tighten them as required. **IMPORTANT:** All FREEMOTION cushions have dense plywood supports with tee-nuts that are used to bolt the cushions to the strength equipment. Because the tee-nuts are held by the plywood, they will not withstand the torque that standard nuts and bolts will. When tightening the bolts securing a cushion, turn them only until they are snug and the cushion does not move or feel loose. Overtightening may strip the tee-nuts from the plywood and make it impossible to remove the cushion in the future.

Cable

1. Check the cable for proper tension (see CABLE ADJUSTMENT on page 8).
2. Check the entire length of the cable by slowly performing one repetition on the strength equipment; inspect the cable that is exposed on the exterior of the strength equipment and the cable inside the tower. Run your fingers along the cable, paying close attention at the bends and attachment points. Watch for the following conditions, which may indicate a worn cable in need of replacement:
 - A. a torn or split cable sheath that exposes the cable
 - B. a kinked or severely bent cable
 - C. a curled or twisted sheath
 - D. a stretched cable sheath, showing a thinning cross-section

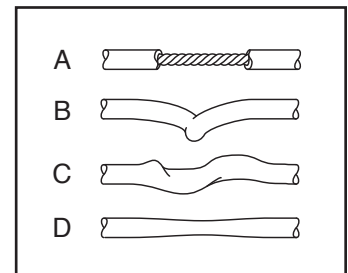

Cable Traps

Check the cable traps (A) to ensure that they are not rubbing (B) against the cables and that they are holding the cables in the grooves of the pulleys. If a cable trap is incorrectly aligned (C), loosen the bolt slightly, readjust the cable trap as necessary, and retighten the bolt.

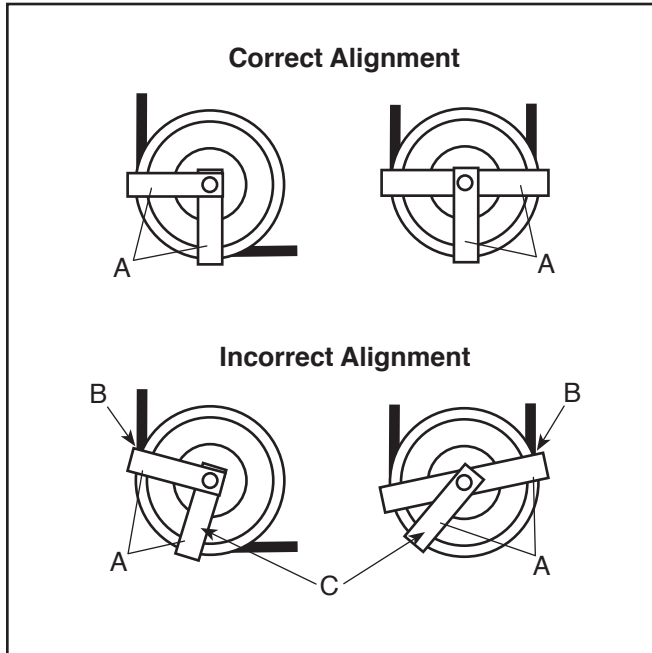

WEIGHT GUIDE LUBRICATION

Clean and lubricate the full length of each weight guide by wiping it with a soft cloth containing a lightweight motor oil, 10W-40 or 10W-30 weight. Apply only a light coating over the entire length of the weight guide. **Do not use TEFLON®-based lubricants.**

CABLE ADJUSTMENT

For the strength equipment to function correctly, the cable must be tensioned correctly. To check the tension of the cable, first pull the weight pin and slide it to the bottom of the weight stack; **do not insert the weight pin into a weight plate.** Next, slowly raise and lower the weight carriage by performing one repetition. The weight carriage should come to rest just on top of the top weight plate when the repetition is completed.

If there is too much tension on the cable, the weight carriage will not rest on the top weight plate, and it may be difficult to insert the weight pin into the weight plates.

If there is not enough tension on the cable, the weight carriage will not be lifted immediately when the repetition is begun. Ideally, the cable should not move more than 1/2 in. (1.3 cm) from the resting position before the weight carriage is lifted.

If there is too much tension or not enough tension on the cable, adjust the cable as described in the following steps.

Weight Carriage Pulley Adjustment

Tools required: 5/16" hex key, 9/16" open-end wrench

1. Remove the tower cover and then remove the back access cover by sliding it upward until the two sets of tabs release.

2. Loosen the locknut (D) attaching the pulley to the bracket on top of the weight carriage.

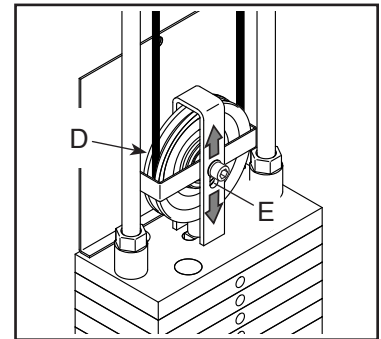

3. If more slack is needed in the cable, move the pulley upward in the slot (E). If less slack is needed, move the pulley downward.
4. Make sure that the cable trap is properly oriented (see Cable Traps at the left), and retighten the locknut (D) attaching the pulley in the bracket.
5. Check the tension of the cable as described above, and readjust it, if necessary.
6. Slowly perform a repetition using a light load and have someone make sure that the cable is not derailed from a pulley or rubbing on a cable trap.
7. Reattach the access cover.

ADDITIONAL ADJUSTMENTS

Cable End Adjustment

Tools required: 1/8" hex key, cable cutters, torque wrench, utility knife

IMPORTANT: Make this adjustment only if the pulley in the weight carriage has been adjusted to the bottom of the slot in the bracket and the cable requires more tension.

Note: This adjustment is only for increasing the cable tension, because it requires shortening the cable. Only one end of the cable should be shortened.

1. To create slack in the cable, pull the weight pin, pull either handle out six to eight inches, and then insert the weight pin into the third weight plate and into the tube on the bottom of the weight carriage.
2. Push the black rubber cable stop (F) off the aluminum cable lock (G) and slide the cable stop upward a few inches.

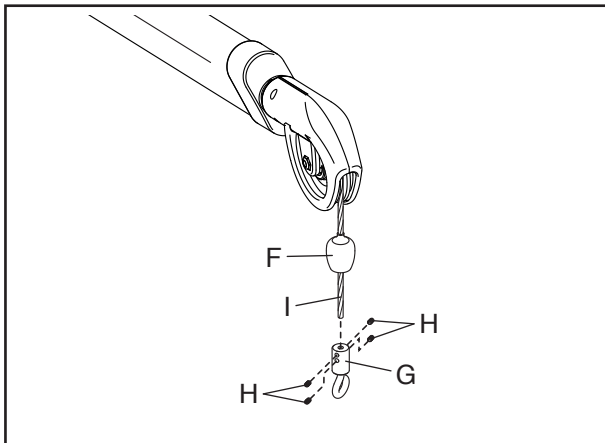

3. Loosen the four set screws (H) in the cable lock (G), and pull the cable (I) free.

4. Cut off one inch of the cable end (I) using cable cutters. **IMPORTANT:** Using any other tool may flatten or disrupt the end strands so that it may be difficult to reinsert the cable into the hole of the cable lock (G).
5. Cut off one inch of the black cable sheath from the end of the cable (I).
6. Reinsert the cable (I) and the sheath into the cable lock (G) so that all of the bare cable is in the hole.
7. Retighten the four set screws (H) into the threaded holes. Tighten the set screws equally until they contact the cable (I). Then, tighten each screw alternately 1/4 turn, until all are set to 85 inch/pounds (9.6 Newton-meters).
8. Slide the rubber cable stop (F) over the cable lock (G), remove the weight pin, and lower the handle.
9. Check for proper tension on the cable as described in CABLE ADJUSTMENT, on page 8.

WEIGHT STACK SERVICING

Servicing the weight stack involves replacing the bushings in the weight carriage. To order these parts, see HOW TO CONTACT CUSTOMER CARE on the back cover of this manual.

1. Remove the tower cover and then remove the back access cover by sliding it upward until the two sets of tabs release.
2. Loosen the top bolt or nuts on each weight guide. Then, remove the bolts or nuts and let the weight guides slide down to the floor.
3. Using a 5/16" hex key and a 9/16" open-end wrench, remove the pulley on the weight carriage. This will make it easier to replace the weight guide bushings.
4. Slide the weight carriage upward off the weight guides. Note: For increased clearance, pull the weight guides toward the back of the tower.
5. Unscrew and remove the existing weight guide bushings (J) from the weight carriage. Discard the existing weight guide bushings.

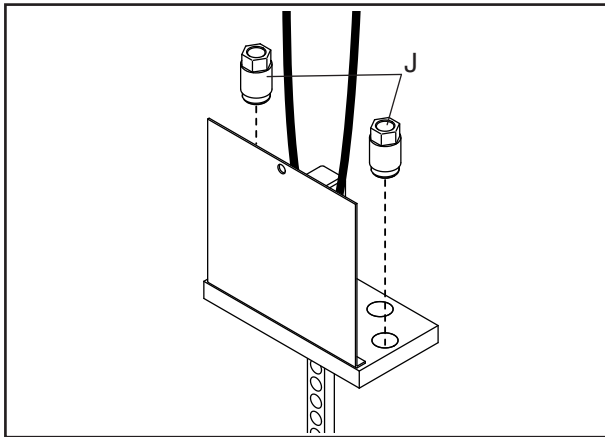

6. Tighten two new weight guide bushings (J) into the weight carriage.
7. Clean and lubricate the weight guides by wiping them using a soft cloth containing a lightweight motor oil, 10W-40 or 10W-30 weight. Apply only a light coating over the entire length. See WEIGHT GUIDE LUBRICATION on page 8.
8. Replace the weight carriage on the weight guides. Then, reattach the pulley, cable, and cable traps.
9. Reattach the weight guides to the top of the tower.
10. Pull the weight pin and slide it to the bottom of the weight stack; **do not insert the weight pin into a weight plate**. Next, pull the handle, lifting the weight carriage all of the way to the top. Then, slowly return the handle to the resting position.

If the weight carriage sticks, loosen one of the weight guide bolts or nuts. Then, lift the weight carriage to the top again, and retighten the weight guide bolt or nuts. Check the full travel again and readjust the weight guides if necessary.

11. Slowly perform a repetition and have someone make sure that the cable is not derailed from a pulley or rubbing on a cable trap.
12. Reattach the access cover.

CABLE DIAGRAM

The cable diagram shows the proper route of the cable. Use the diagram to make sure that the cable and the cable traps have been assembled correctly. If the cable has not been correctly routed, the strength equipment will not function properly and damage may occur. The numbers show the correct route of the cable. **Make sure that the cable traps do not touch or bind the cable.**

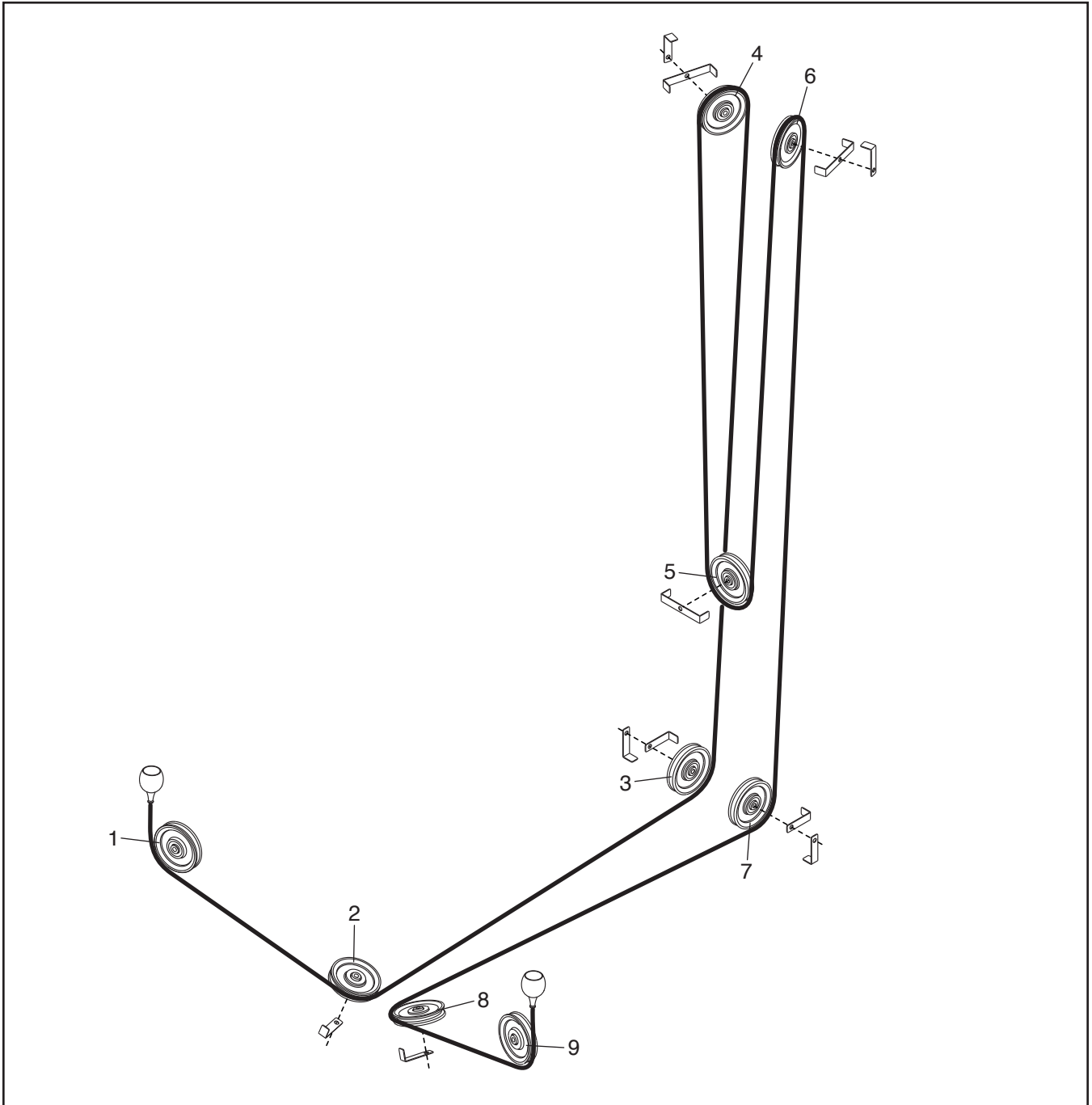

NOTES

PART LIST

Model No. G601.0 R0419A

Key No.	Qty.	Description	Key No.	Qty.	Description
1	1	Tower	40	2	Snap Ring
2	1	Tower Cover	41	2	Cable Stop
3	1	Left Stabilizer	42	2	Cable Lock
4	1	Right Stabilizer	43	2	Eyebolt
5	1	Left Stabilizer Cover	44	2	Cable Clip
6	1	Right Stabilizer Cover	45	2	5/16" Locknut
7	2	Stabilizer Cap	46	2	Cable Lock Spacer
8	3	Foot	47	2	Inner Snap Ring
9	4	Short Roll Pin	48	8	1/4" x 3/8" Set Screw
10	1	Lower Cover	49	4	#8 x 1/2" Screw
11	2	Kick Cover	50	2	#10 x 3/4" Screw
12	1	3/8" x 2 1/4" Screw	51	4	1/2" x 1" Screw
13	1	Access Cover	52	6	3/8" x 1/2" Screw
14	1	Weight Carriage	53	4	1/4" x 5/8" Screw
15	8	Small Weight Plate	54	8	3/8" x 1" Patch Screw
16	9	Weight Plate	55	6	3/8" x 2" Screw
17	2	Weight Cushion	56	1	3/8" x 3" Bolt
18	2	Weight Guide	57	2	1/2" x 3" Screw
19	2	Weight Guide Bushing	58	7	1/4" x 3/8" Screw
20	1	Weight Pin	59	8	3/8" Locknut
21	1	Weight Bumper	60	4	5/8" Jam Nut
22	2	Cable Trap	61	1	1/4" Locknut
23	1	Double Cable Trap	62	2	Small Double Cable Trap
24	7	Pulley	63	2	3/8" Serrated Lock Washer
25	2	Small Pulley	64	4	5/8" Split Washer
26	6	Large Cable Trap	65	4	M8 x 25mm Screw
27	1	Frame	66	1	Left Arm Cover
28	1	Frame Cover	67	1	Right Arm Cover
29	1	Seat	68	2	Limiter
30	1	Backrest	69	2	Long Roll Pin
31	1	Frame Arm	70	1	Cable
32	2	M8 x 75mm Screw	71	1	Hook Fastener Tape
33	2	Arm Cover	72	1	Loop Fastener Tape
34	1	Frame Cap	73	2	Long Magnetic Tape
35	2	Handle	74	2	Small Magnetic Tape
36	2	Outer Pulley Bracket	75	1	Small Top Weight Plate
37	2	Inner Pulley Bracket	76	1	Large Bottom Weight Plate
38	2	Pivot Tube	77	1	Backrest Cover
39	4	Bearing	*	—	Owner's Manual

Note: Specifications are subject to change without notice. For information about ordering replacement parts, see the back cover of this manual. *These parts are not illustrated.

EXPLODED DRAWING A

Model No. G601.0 R0419A

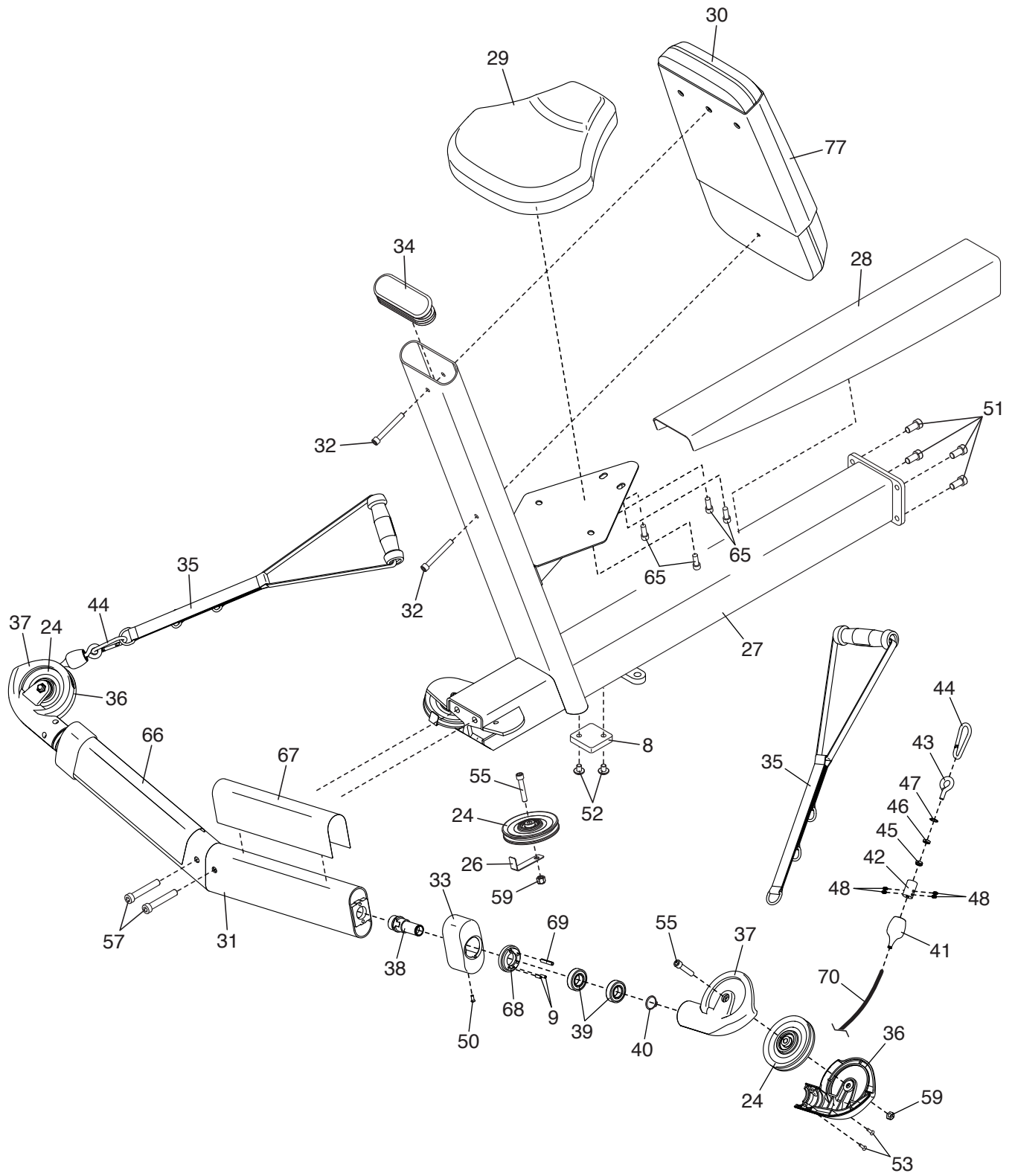

EXPLODED DRAWING B

Model No. G601.0 R0419A

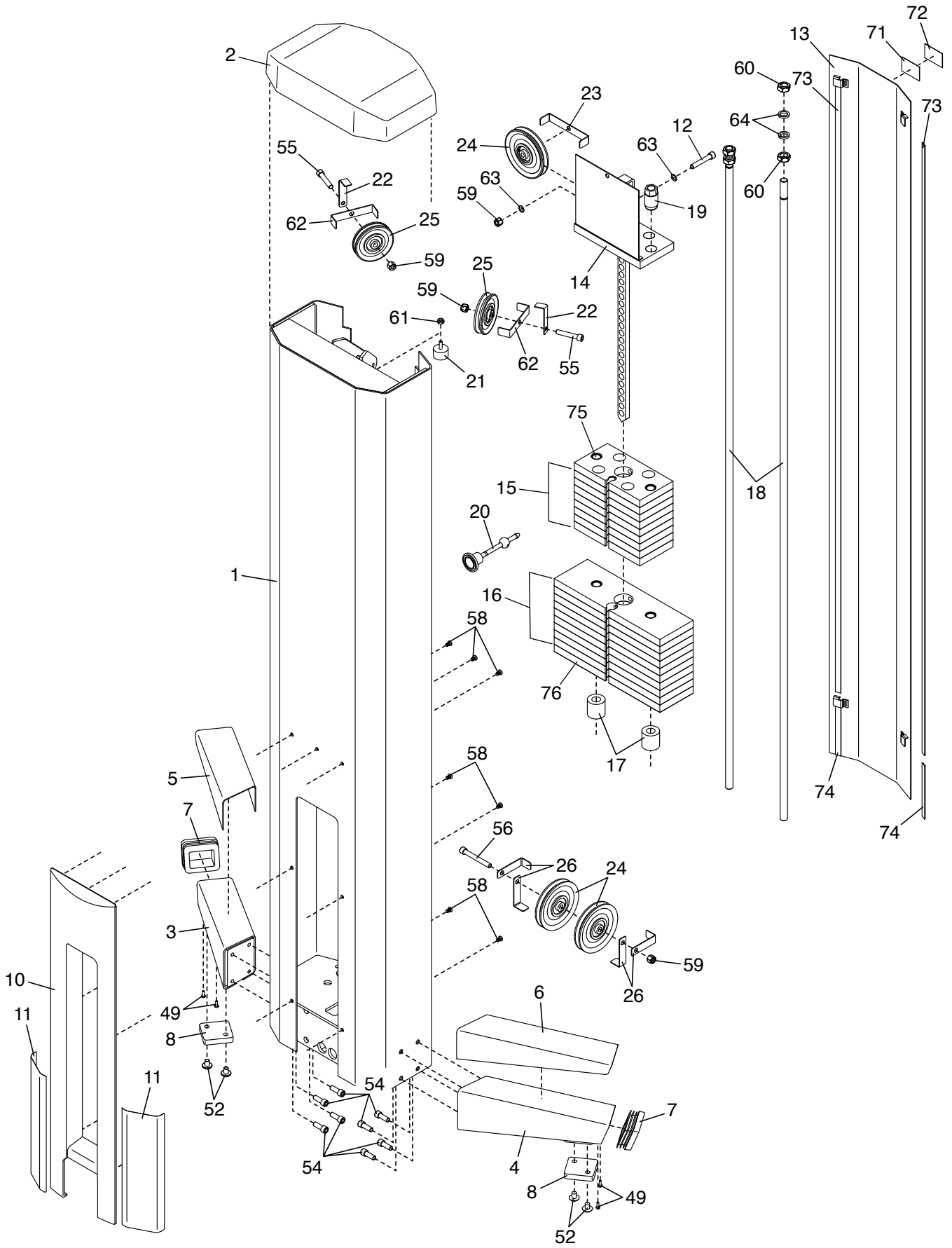

HOW TO CONTACT CUSTOMER CARE

If you have questions after reading this manual, or if parts are damaged or missing, please contact Customer Care at one of the phone numbers or addresses listed below. **Please note the model number, serial number, and name of the product (see the front cover of this manual) before contacting Customer Care. If you are ordering replacement parts, please also note the key number and description of each part (see the PART LIST and the EXPLODED DRAWING near the end of this manual).**

In the United States

Call: 1-800-201-2109, Mon.–Fri. 6 a.m.–6 p.m. MT

Email: customercare@freemotionfitness.com

Write:

Freemotion Fitness
1500 South 1000 West
Logan, UT 84321-9813
United States

Outside the United States

Call: 001-800-527-5417 or 001-435-786-3521,

Mon.–Fri. 6 a.m.–3 p.m. USA Mountain Time

Email: intlcustomercare@freemotionfitness.com

LIMITED WARRANTY

WARRANTY PERIODS AND COVERAGE

Freemotion Fitness warrants this product to be free from defects in workmanship and material under normal use and service conditions. Parts and labor are warranted for one (1) year, unless otherwise specified on the invoice.

The warranty period commences on the invoice date of purchase. Any parts repaired or replaced during this warranty period will be warranted for the remainder of the original warranty period.

CONDITIONS AND LIMITATIONS

The following will void the warranty on this product:

1. This warranty applies only to the original owner and is non-transferable.
2. The labor warranty applies only to products sold in the US and Canada. Contact your authorized Freemotion Fitness dealer for details on labor coverage in your country.
3. Any misuse, abuse, or improper service.
4. Users in excess of the maximum user weight listed in this manual. Note: This product may not have a maximum user weight.
5. Damage caused by moving the product or improper storage including moving or storing the product on its side.
6. Use or storage of the product outdoors or in high-humidity environments including spa and pool areas.
7. Damage caused by improper wiring or insufficient electrical current. Note: This product may not have wiring.

This warranty shall not apply to the following:

1. Cosmetic items including grips, decals, and labels.

2. Pick-up and delivery or freight charges involved with a repair.
3. Any problem as a result of improper assembly or delivery.

WHAT TO DO IF SERVICE IS REQUIRED

Freemotion Fitness warranty service may be obtained by contacting the authorized dealer from which you purchased this product. Make sure to retain your original invoice and serial number information. If this product experiences a failure under the warranty terms set forth, Freemotion Fitness shall provide at their option either repair, replacement, or refund of the purchase price. Freemotion Fitness compensates service providers for warranty trips within their service area. You may be charged additionally for service calls beyond this service area.

Freemotion Fitness is not responsible or liable for indirect, special, or consequential damages arising out of or in connection with the use or performance of the product; damages with respect to any economic loss, loss of property, loss of revenues or profits, loss of enjoyment or use, or cost of removal or installation; or other consequential damages. Some regions do not allow the exclusion or limitation of consequential damages. Accordingly, the above limitation may not apply to you. This warranty gives you specific rights, and you may have other rights that vary from region to region.

TO CONTACT FREEMOTION FITNESS

See HOW TO CONTACT CUSTOMER CARE above.