



PACER SMART COMPACT AUTO INCLINE TREADPAD TREADMILL

SF-T722076

USER MANUAL



IMPORTANT! Please retain owner's manual for maintenance and adjustment instructions. Your satisfaction is very important to us, **PLEASE DO NOT RETURN UNTIL YOU HAVE CONTACTED US:** support@sunnyhealthfitness.com or 1-877-90SUNNY (877-907-8669).



WWW.SUNNYHEALTHFITNESS.COM

IMPORTANT SAFETY INSTRUCTION

When using an electrical appliance, basic precautions should always be followed, including the following:

Read all instructions before using (this appliance).

DANGER – To reduce the risk of electric shock:

Always unplug this appliance from the electrical outlet immediately after using and before cleaning.

WARNING – To reduce the risk of burns, fire, electric shock, or injury to persons:

1. An appliance should never be left unattended when plugged in. Unplug from outlet when not in use, and before putting on or taking off parts.
2. This appliance is not intended for use by persons with reduced physical, sensory, or mental capabilities, or lack of experience and knowledge, unless they have been given supervision or instruction concerning use of the appliance by a person responsible for their safety. Keep children under the age of 13 away from this machine.
3. Use this appliance only for its intended use as described in this manual. Do not use attachments not recommended by the manufacturer.
4. Never operate this appliance if it has a damaged cord or plug, if it is not working properly, if it has been dropped or damaged, or dropped into water. Return the appliance to a service center for examination and repair.
5. Do not carry this appliance by supply cord or use cord as a handle.
6. Keep the cord away from heated surfaces.
7. Never operate the appliance with the air openings blocked. Keep the air openings free of lint, hair, and the like.
8. Never drop or insert any object into any opening.
9. Do not use outdoors. Household use only.
10. Do not operate where aerosol (spray) products are being used or where oxygen is being administered.
11. To disconnect, turn all controls to the off position, then remove plug from outlet.
12. CAUTION: Risk of Injury to Persons – To Avoid Injury, use extreme caution when stepping onto or off of a moving belt. Read Instruction Manual Before Using.
13. Connect this appliance to a properly grounded outlet only. See Grounding Instructions.
14. REMOVE CONTROL BOX (OR KEY, OR SAFETY PIN, AS APPLICABLE) WHEN NOT IN USE, AND STORE OUT OF REACH OF CHILDREN.
15. Do not operate under blanket or pillow. Excessive heating can occur and cause fire, electric shock, or injury to persons.

SAVE THESE INSTRUCTIONS

CAUTION: The user is cautioned that changes or modifications not expressly approved by the party responsible for compliance could void the user's authority to operate the equipment.

This device contains license-exempt transmitter(s)/receiver(s) that comply with Innovation, Science and Economic Development Canada's license-exempt RSS(s) and Part 15 of the FCC Rules. Operation is subject to the following two conditions:

- 1) This device may not cause interference.
- 2) This device must accept any interference, including interference that may cause undesired operation of the device.

NOTE: This equipment has been tested and found to comply with the limits for a Class B digital device, pursuant to Part 15 of the FCC Rules. These limits are designed to provide reasonable protection against harmful interference in a residential installation. This equipment generates, uses, and can radiate radio frequency energy and, if not installed and used in accordance with the instructions, may cause harmful interference to radio communications. However, there is no guarantee that interference will not occur in a particular installation.

If this equipment does cause harmful interference to radio or television reception, which can be determined by turning the equipment off and on, the user is encouraged to try to correct the interference by one or more of the following measures:

- Reorient or relocate the receiving antenna.
- Increase the separation between the equipment and receiver.
- Connect the equipment into an outlet on a circuit different from that to which the receiver is connected.
- Consult the dealer or an experienced radio/TV technician for help.

FCC & IC Radiation Exposure Statement:

This equipment complies with FCC and Canada radiation exposure limits set forth for an uncontrolled environment. This equipment should be installed and operated with a minimum distance of 20cm between the radiator and your body.

This transmitter must not be co-located or operating in conjunction with any other antenna or transmitter.

IMPORTANT SAFETY INFORMATION

We thank you for choosing our product. To ensure your safety and health, please use this equipment correctly. It is important to read this entire manual before assembling and using the equipment. Safe and effective use can only be achieved if the equipment is assembled, maintained and used properly. It is your responsibility to ensure that all users of the equipment are informed of all warnings and precautions.

1. Before starting any exercise program, you should consult your physician to determine if you have any medical or physical conditions that could put your health and safety at risk or prevent you from using the equipment properly. Your physician's advice is essential if you are taking medication that affects your heart rate, blood pressure, or cholesterol level.
2. Be aware of your body's signals. Incorrect or excessive exercise can damage your health. Stop exercising if you experience any of the following symptoms: pain, tightness in your chest, irregular heartbeat, shortness of breath, lightheadedness, dizziness, or feelings of nausea. If you do experience any of these conditions, you should consult your physician before continuing with your exercise program.
3. Keep children and pets away from the equipment. The equipment is designed for adult use only.
4. Use the equipment on a solid, flat level surface with a protective cover for your floor or carpet. To ensure safety, the equipment should have at least 8 feet (240cm) of free space behind it and 2 feet (60CM) on each side. Do not place the treadmill on any surface that blocks air openings. To protect the floor or carpet from damage, place a mat under the treadmill.
5. Ensure that all nuts and bolts are securely tightened before using the equipment. The safety of the equipment can only be maintained if it is regularly examined for damage and/or wear and tear.
6. Always use the equipment as indicated. If you find any defective components while assembling or checking the equipment, or if you hear any unusual noises coming from the equipment during exercise, discontinue use of the equipment immediately and do not use until the problem has been rectified.
7. Wear suitable clothing while using the equipment. Avoid wearing loose clothing that may become entangled in the equipment.
8. Do not place fingers or objects into the moving parts of the equipment.
9. The maximum weight capacity of this unit is 265 lbs (120 kgs).
10. This equipment is not suitable for therapeutic use.
11. To avoid bodily injury and/or damage to the product or property, proper lifting and moving are required.
12. Your product is intended for use in cool and dry conditions. You should avoid storage in extreme cold, hot, or damp areas as this may lead to corrosion and other related problems.
13. This equipment is designed for indoor and home use only; it is not intended for commercial use!

IMPORTANT OPERATING INSTRUCTIONS

1. Insert the power plug directly into the socket.
2. Read the manual before operating the equipment.
3. Changes in speed do not occur immediately. Set your desired speed using the adjustment keys on the main console. The speed will increase gradually.
4. While on the treadmill, move with caution as distractions may cause you to lose balance and stray from walking in the center of the belt. This may result in serious injury.
5. This unit starts at a very low speed. To begin use, hold onto the handrails and stand on the side rails while it starts up, then step onto the belt once it's in motion.
6. Always hold the handrail when making changes in the settings.
7. A safety key is provided for emergency use. The machine will function only if the safety key is inserted into the computer console. In case of emergency, remove the safety key to immediately stop the belt and shut off the treadmill. The display screen will reset once the safety key is reinserted.
8. The console control keys are precisely set and require very little finger pressure to use. To avoid damaging these keys, do not use excessive pressure when operating these controls.
9. This equipment is designed for adult use only! Children should not be allowed to use or play near this equipment. When present, children should always be supervised by an adult.
10. Women who are pregnant or nursing should consult a physician before attempting to begin any exercise program.
11. Always stay hydrated during and after exercise.









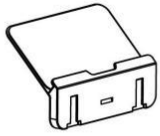

IMPORTANT NOTE:

The running belt must be lubricated before the first use! Please see *Page 10* for instructions on how to properly apply lubricant.

PRE-ASSEMBLY CHECK LIST

Before you start to assemble, please make sure all parts are included.

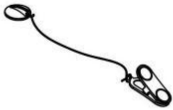
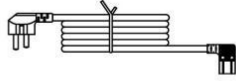
 A	 B	 C	 D
 E	 F	 B11	 C14
 E08	 E09	 E11	

No.	Description	Spec.	Qty.
A	Main Frame		1
B	Tablet Holder		1
C	Lubricant Oil		1
D	Manual		1
E	THANK YOU Card		1
F	Battery		1
B11	Screwdriver		1
C14	T-Shape Wrench		1
E08	Remote Control		1
E09	Safety Key		1
E11	Power Wire		1

Ordering Replacement Parts (U.S. and Canadian Customers only)

Please provide the following information in order for us to accurately identify the part(s) needed:

- ✓ The model number (found on cover of manual)
- ✓ The product name (found on cover of manual)
- ✓ The part number found on the “EXPLODED DIAGRAM” (page 25~26) and “PARTS LIST” (page 27~28)

Please contact us at support@sunnyhealthfitness.com or 1-877-90SUNNY (877-907-8669).

BATTERY SAFETY WARNING

WARNING

- **INGESTION HAZARD:** This product contains a button cell or coin battery.
- **DEATH** or serious injury can occur if ingested.
- A swallowed button cell or coin battery can cause **Internal Chemical Burns in as little as 2 hours.**
- **KEEP** new and used batteries **OUT OF REACH OF CHILDREN**
- **Seek immediate medical attention** if a battery is suspected to be swallowed or inserted inside any part of the body



NOTES:

- 1) Remove and immediately recycle or dispose of used batteries according to local regulations and keep away from children. Do NOT dispose of batteries in household trash or incinerate.
- 2) Even used batteries may cause severe injury or death.
- 3) Call a local poison control center for treatment information.
- 4) The compatible battery type CR2032 3V.
- 5) Non-rechargeable batteries are not to be recharged.
- 6) Do not force discharge, recharge, disassemble, heat above 50° C/122° F, or incinerate. Doing so may result in injury due to venting, leakage or explosion, resulting in chemical burns.
- 7) Ensure the batteries are installed correctly according to polarity (+ and -).
- 8) Remove and immediately recycle or dispose of batteries from equipment not used for an extended period of time according to local regulations.
- 9) Always completely secure the battery compartment. If the battery compartment does not close securely, stop using the product, remove the batteries, and keep them away from children.

ASSEMBLY INSTRUCTIONS

We value your experience using Sunny Health and Fitness products. For assistance with parts or troubleshooting, please contact us at support@sunnyhealthfitness.com or 1-877-90SUNNY (877-907-8669).

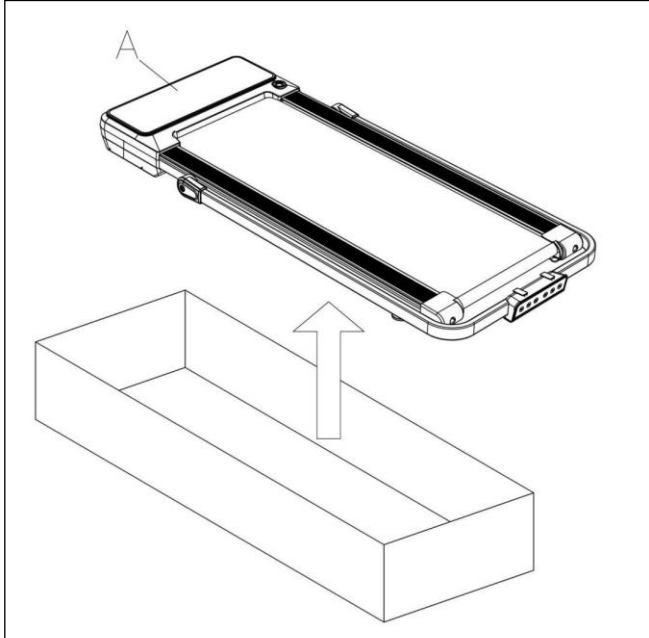

STEP 1:

Open the carton and remove contents. Place the **Main Frame (No. A)** on level ground, ensure that you have a work area that is clean and has adequate space.

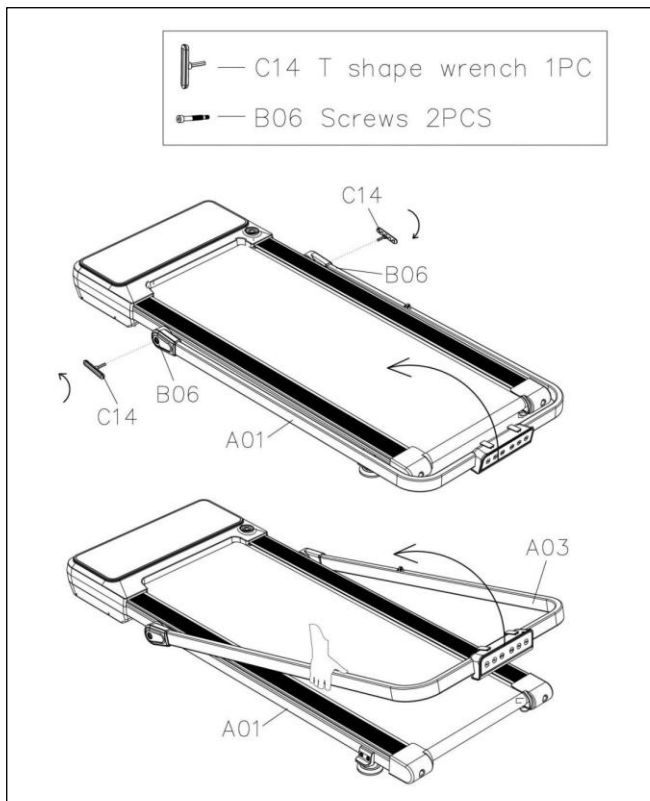

STEP 2:

Loosen the 2 **Screws (No. B06)** *counter-clockwise* by using **T-Shape Wrench (No. C14)**.

Lift the **Upright Tube (No. A03)** upward (in the direction specified by the arrows on the diagram to the left).

We value your experience using Sunny Health and Fitness products. For assistance with parts or troubleshooting, please contact us at support@sunnyhealthfitness.com or 1-877-90SUNNY (877-907-8669).

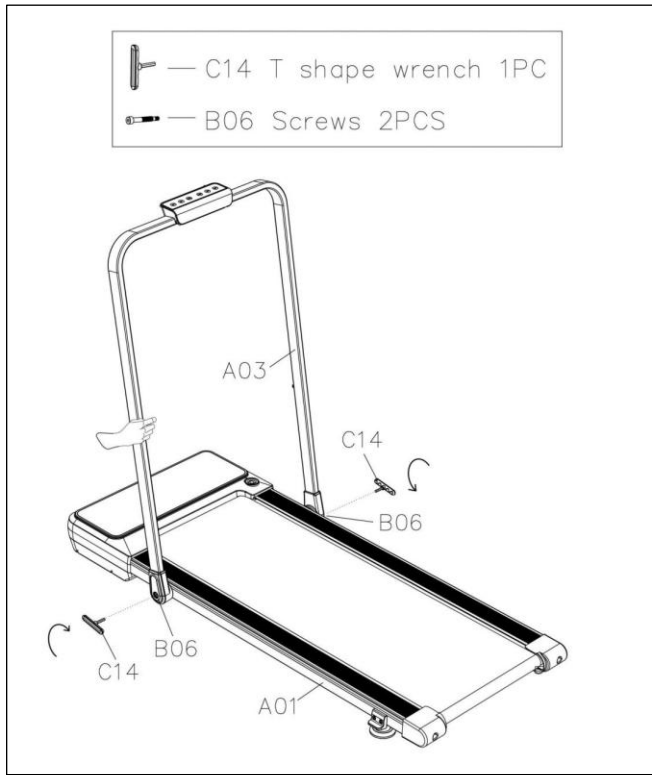

STEP 3:

Support the **Upright Tube (No. A03)** with your hands to prevent them from falling.

Fix the 2 **Screws (No. B06)** inside **Upright Tube (No. A03)** to the **Main Frame (No. A01)** *clockwise* by using **T-Shape Wrench (No. C14)**.

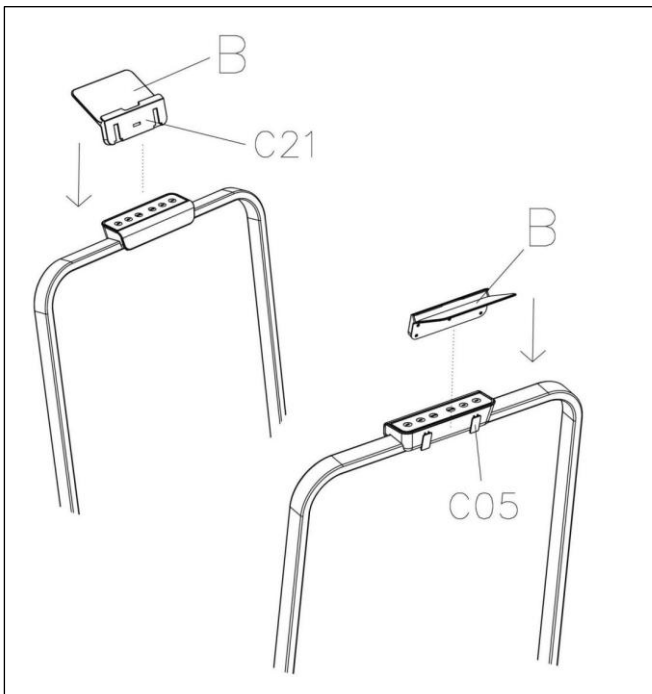

STEP 4:

Insert the **Tablet Holder (No. B)** to **Tablet Holder Bottom Cover (No. C05)**.

We value your experience using Sunny Health and Fitness products. For assistance with parts or troubleshooting, please contact us at support@sunnyhealthfitness.com or 1-877-90SUNNY (877-907-8669).

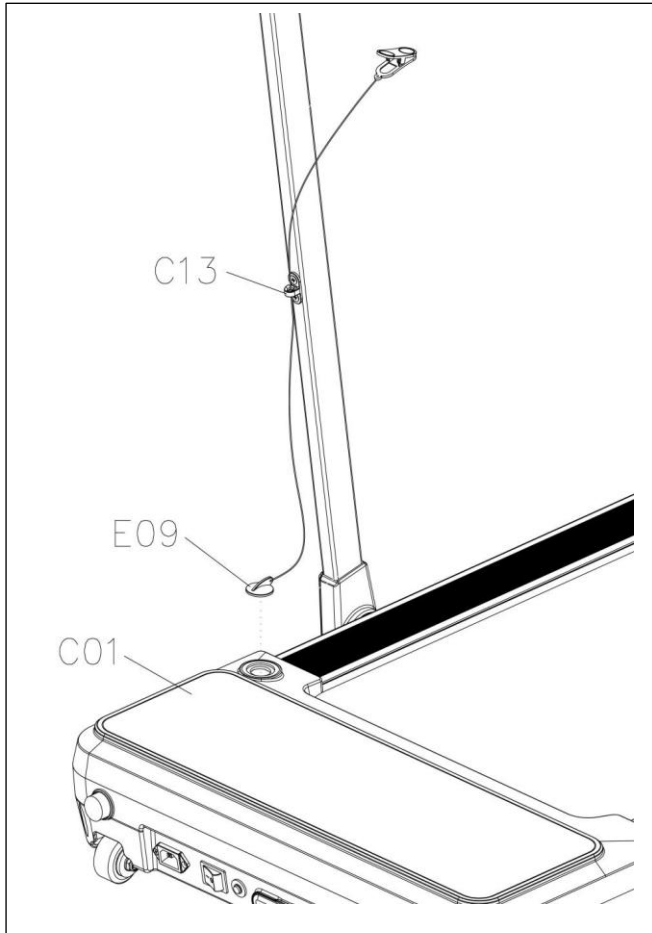

STEP 5:

Insert the magnet end of **Safety Key (No. E09)** onto the **Motor Top Cover (No. C01)**.

Put the wire of **Safety Key (No. E09)** through the **Lead Wire Buckle (No. C13)** and then clip on the clothes, start to use the machine.



IMPORTANT NOTE!

You will need to lubricate your treadmill before the first use. See *Page 10*.

LUBRICATING THE TREADMILL

IMPORTANT NOTE:

You will need to lubricate your treadmill before the first use.

RUNNING BELT & TREADMILL LUBRICANT:

Lubricating the **Running Board (No. E10)** and **Running Belt (No. C11)** is essential as the friction affects the life span and operations of the treadmill. Inspect the **Running Belt (No. C11)** and **Running Board (No. E10)** regularly. If you find any wear on the **Running Board (No. E10)**, please contact us at: support@sunnyhealthfitness.com.

WARNING: Always unplug the treadmill from the electrical outlet before cleaning, lubricating, or repairing the unit.

HOW TO LUBRICATE:

1. To apply lubricant, lift one side of the **Running Belt (No. C11)** and apply oil to the middle of the **Running Board (No. E10)**. Next, start the treadmill and place it at the lowest speed setting and allow the oil to spread over the **Running Board (No. E10)**. Repeat this process for the other side.
2. The moving parts should turn freely and quietly. Abnormal moving parts will affect the safety of the equipment. Inspect and tighten bolts regularly.
3. To better maintain the treadmill and prolong its lifespan, it is suggested that maintenance be done on a regular basis.
4. DO NOT LOOSEN OR MAKE ANY ADJUSTMENTS TO THE RUNNING BELT WHILE APPLYING LUBRICANT. A loose **Running Belt (No. C11)** will result in the runner sliding off during use, while too tight of a **Running Belt (No. C11)** will negatively affect the motor's performance and create more friction between the roller and **Running Belt (No. C11)**. The most suitable tightness for the **Running Belt (No. C11)** is when it is pulled out **50-75mm** from the **Running Board (No. E10)**.

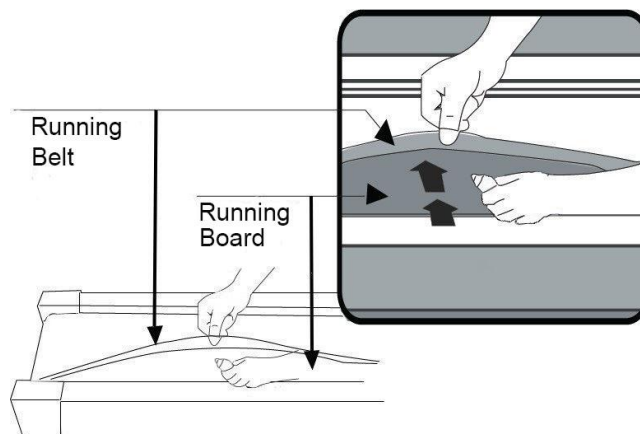

The following time table is recommended:

Light user (less than 3 hours/ week)	<i>every six months</i>
Medium user (3-5 hours/ week)	<i>every three months</i>
Heavy user (more than 5 hours/ week)	<i>every two months</i>

HOW TO FOLD THE MACHINE

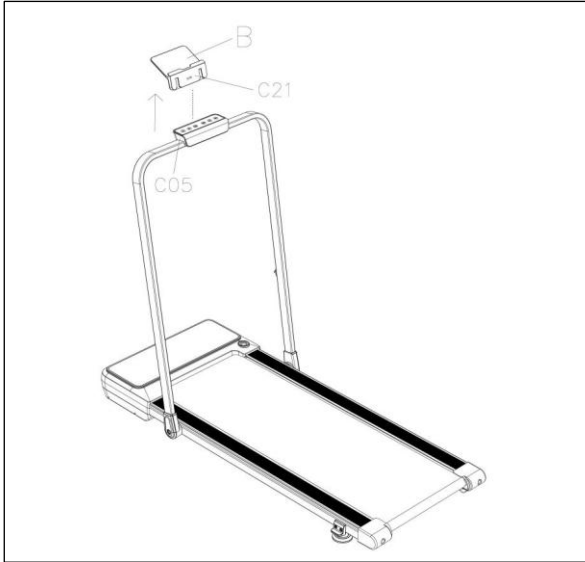

STEP 1:

Pull out the **Tablet Holder (No. B)** from **Tablet Holder Bottom Cover (No. C05)**.

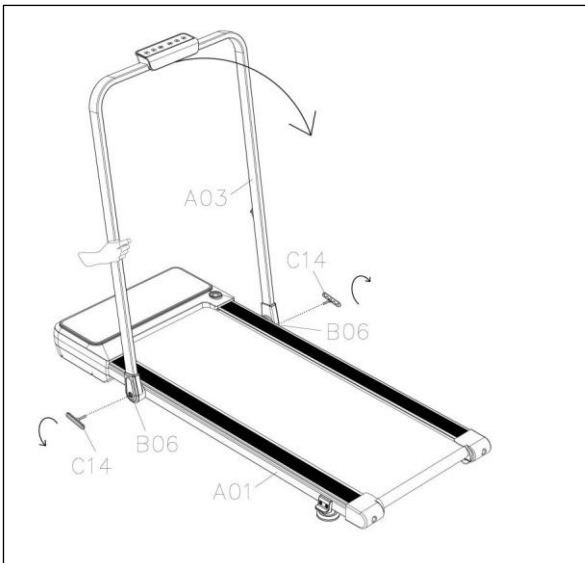

STEP 2:

Loosen the 2 **Screws (No. B06)** of the **Upright Tube (No. A03)** counter-clockwise by using **T-Shape Wrench (No. C14)**.

Pull the **Upright Tube (No. A03)** downward (in the direction specified by the arrows on the diagram).

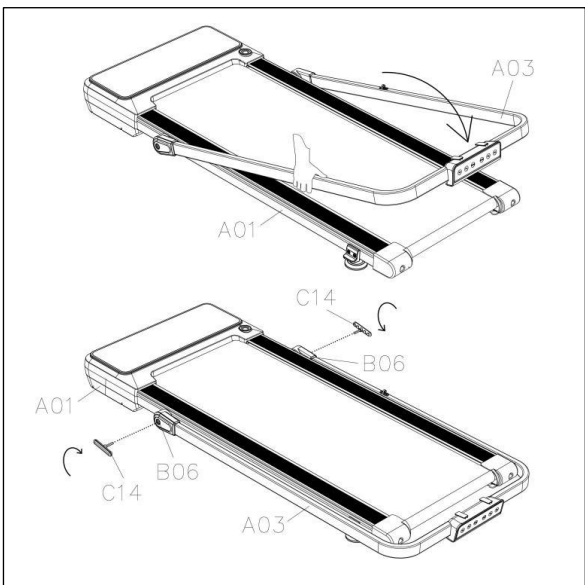

STEP 3:

Fix the 2 **Screws (No. B06)** on **Upright Tube (No. A03)** to the **Main Frame (No. A01)** clockwise by using **T-Shape Wrench (No. C14)**.

HOW TO STORE T-SHAPE WRENCH



When you do not need to use the **T-Shape Wrench (No. C14)**, you can put this wrench into groove of the **Motor Bottom Cover (No. C02)**.

HOW TO MOVE THE TREADMILL

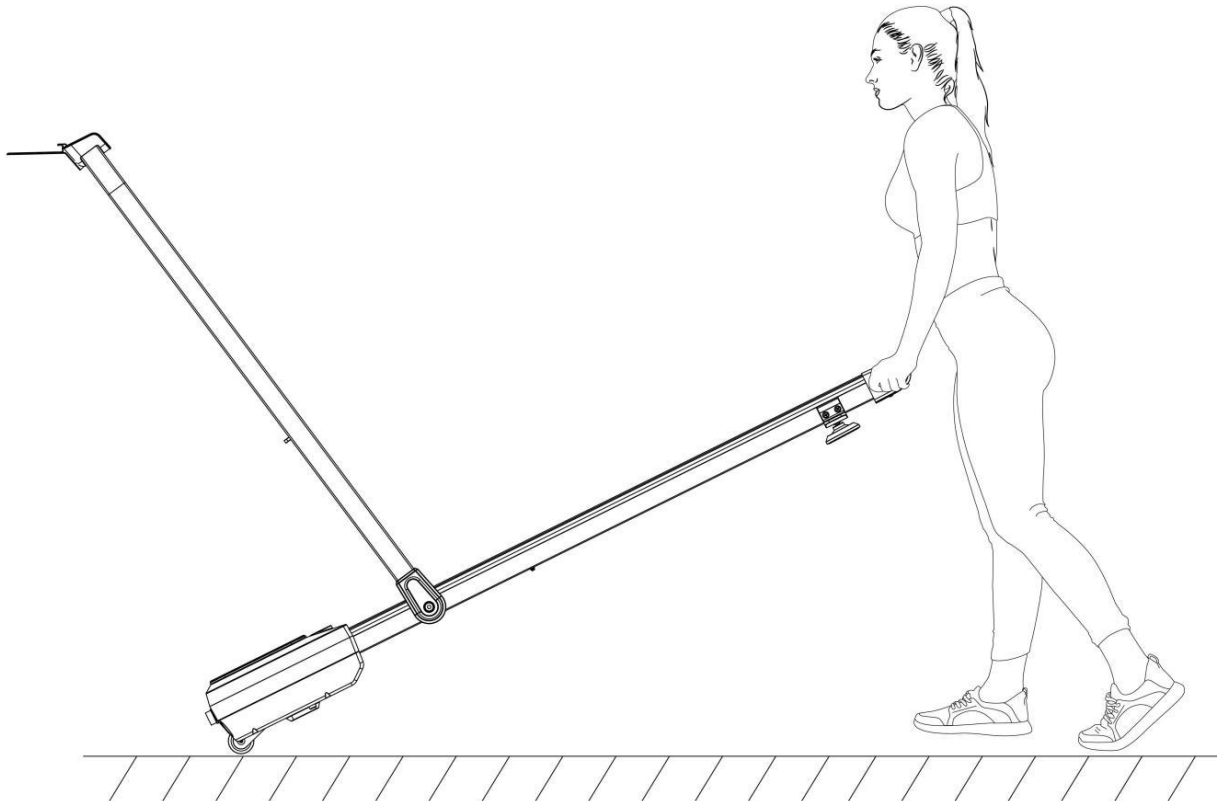
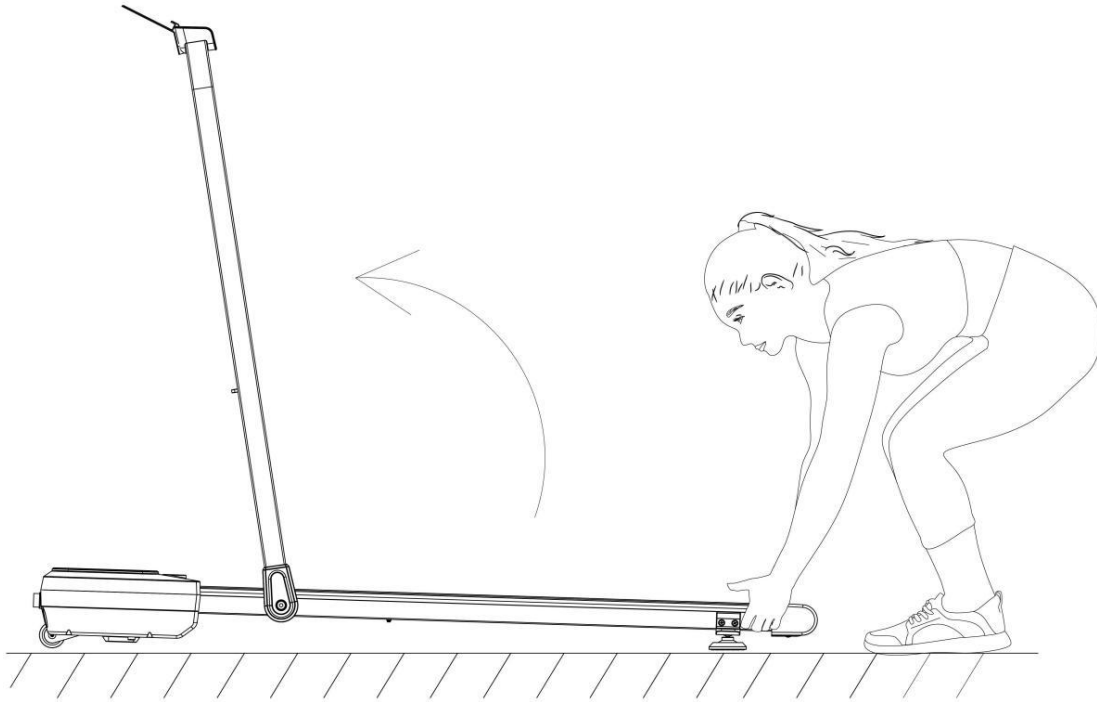

Hold the treadmill at position as above with your hand. Lift up the treadmill and then you can move the treadmill to any place.

HOW TO ADJUST THE BALANCE

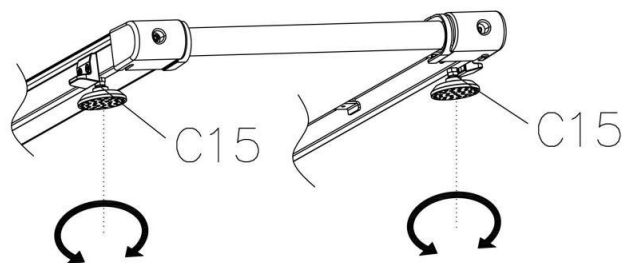
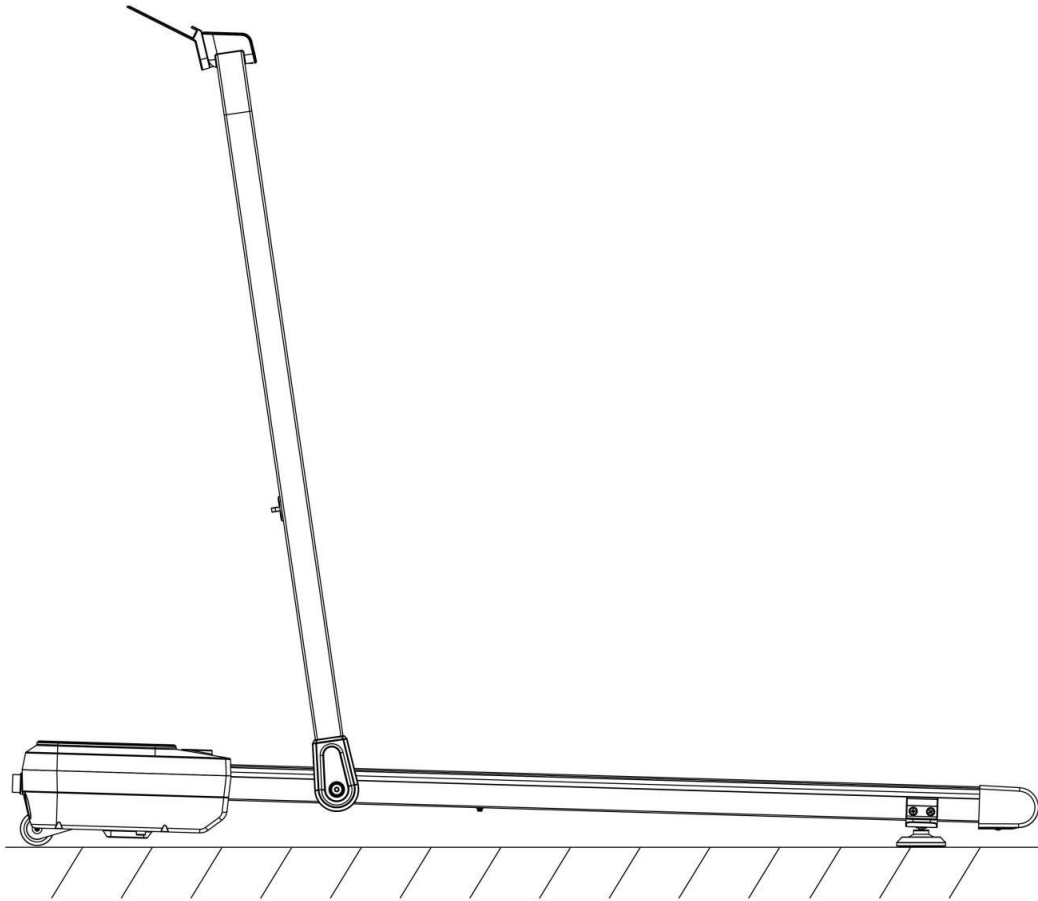

When the height of each pad or because of individual machine placed on the ground is not even, you need to adjust the **Universal Foot Pad Set (No. C15)** to level the machine on the ground.

Adjustment method: First, place the machine as shown in above, and adjust the **Universal Foot Pad Set (No. C15)** clockwise to lower the foot pad and counter-clockwise to raise the foot pad. If required, repeat this process to adjust the remaining base levelers.

HOW TO USE SAFETY KEY

When the handrails stand up, the treadmill is running mode. When you are running, you can put the wire of **Safety Key (No. E09)** through **Lead Wire Buckle (No. C13)** on the **Upright Tube (No. A03)** and slip to your clothes.

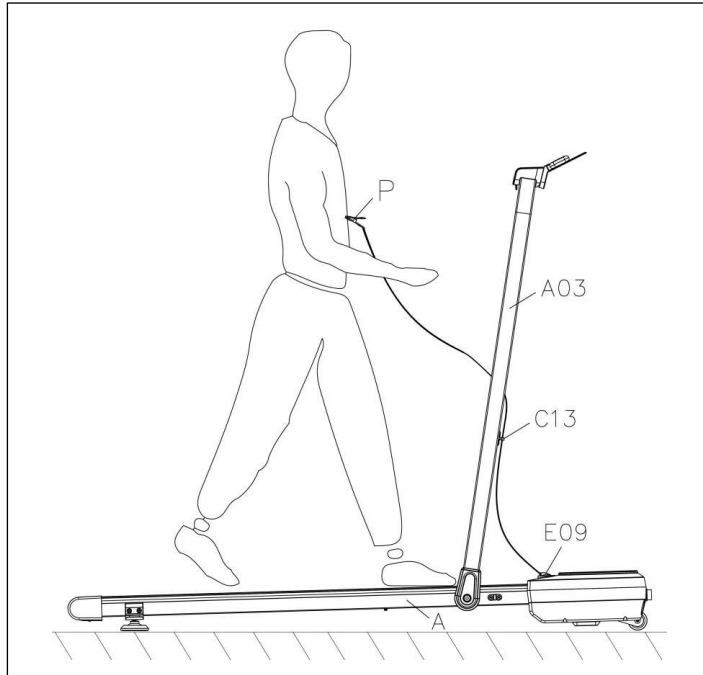

When the handrails lie down, the treadmill is walking mode. When you are walking, you can put the wire of **Safety Key (No. E09)** through **Lead Wire Buckle (No. C13)** on the **Main Frame (No. A)** and slip to your clothes.

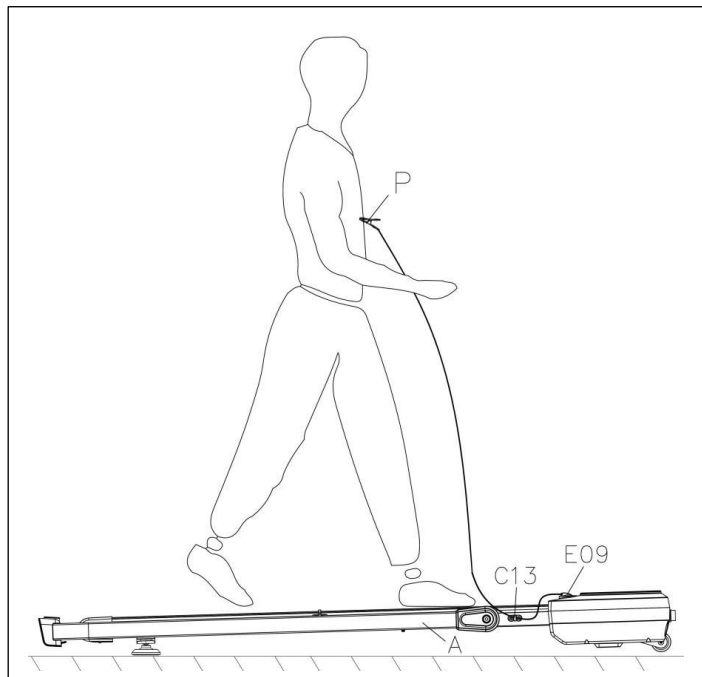

MAINTENANCE & CARE

General cleaning will help prolong the life and improve the performance of your treadmill. Keep the unit clean and maintained by dusting the components on a regular basis. Cleaning two exposed sides of the **Running Belt (No. C11)** will prevent dust from accumulating underneath. Keep your running shoes clean so that dirt from your shoes does not wear out the **Running Board (No. E10)** and **Running Belt (No. C11)**. Clean the surface of the **Running Belt (No. C11)** with a clean damp cloth.

To better maintain the treadmill and prolong its life, it is suggested that the treadmill be powered off for 10 minutes every 2 hours and fully powered off whenever not in use.

CENTERING THE RUNNING BELT:

Place the treadmill on level ground and set it at 3-5MPH to check if the **Running Belt (No. C11)** drifts from the center.

Note: **T-Shape Wrench (No. C14)** is built into the groove of the **Motor Bottom Cover (No. C02)**.

If the **Running Belt (No. C11)** moves to the right, turn the right adjusting bolt $\frac{1}{4}$ turn *clockwise*, then turn the left adjusting bolt $\frac{1}{4}$ turn *counter-clockwise*. If the **Running Belt (No. C11)** does not move, repeat this step until it centers. Refer to Figure A.

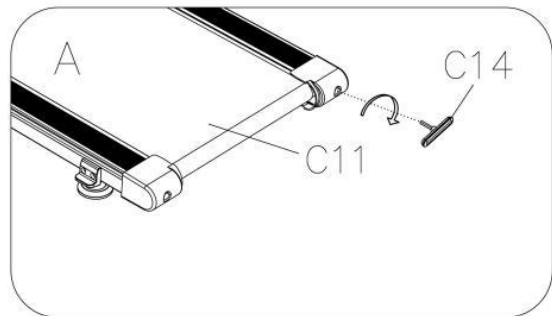

If the **Running Belt (No. C11)** moves to the left, turn the left adjusting bolt $\frac{1}{4}$ turn *clockwise*, then turn the right adjusting bolt $\frac{1}{4}$ turn *counter-clockwise*. If the **Running Belt (No. C11)** does not move, repeat this step until it centers. Refer to Figure B.

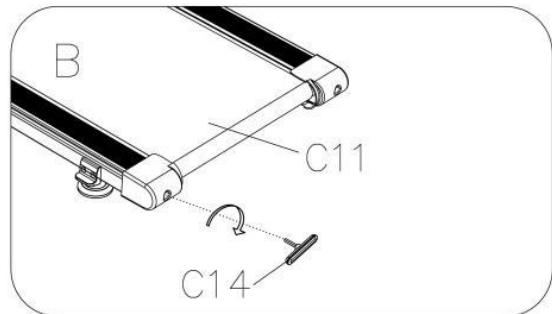

Over time, the **Running Belt (No. C11)** will loosen. To tighten the **Running Belt (No. C11)**, turn the left & right adjusting bolts one full turn *clockwise*, check the tension of the **Running Belt (No. C11)**. Continue this process until **Running Belt (No. C11)** is at the correct tension. Make sure to adjust both sides equally to ensure correct belt alignment. Refer to Figure C.

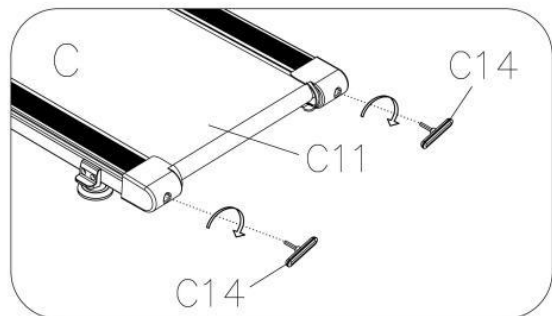

IMPORTANT ELECTRICAL INFORMATION

WARNING: This treadmill requires a power source of **10 amps (100-120V)** in order to properly operate. For your safety, as well as the safety of others, please verify that the power source is correct before plugging in the equipment. Any power source above or below this level could cause significant damage to the equipment and/or user.

GROUNDING METHODS:

This product must be grounded. Grounding provides a path of the least resistance for electrical current to reduce the risk of electric shock. The plug must be plugged into an appropriate outlet that is properly installed and grounded in accordance with all local codes and ordinances. Ensure that the product is connected to an outlet which contains the same configuration as the plug. Do not use an adapter for this product.

This product is for use on a nominal 100-120V circuit and has a grounding plug that looks like the plug illustrated in sketch A.

DANGER:

Improper connection of the equipment can result in risk of electric shock. Check with a qualified electrician or serviceman if you are unsure whether the product has been properly grounded. Do not modify the plug provided with this product. If it will not fit the outlet, have a proper outlet installed by a qualified electrician.

WARNING!

1. **NEVER** use a ground fault circuit interrupt (GFCI) wall outlet with this treadmill. Route the power cord away from all moving parts of the treadmill, including the elevation mechanism and transportation wheels.
2. **NEVER** operate the treadmill using a generator or UPS power supply.
3. **NEVER** remove any cover on the treadmill without first disconnecting power cord.
4. **NEVER** expose the treadmill to rain or moisture. This treadmill is not designed for outdoor use or use in any high humidity environment.

GROUNDING METHOD

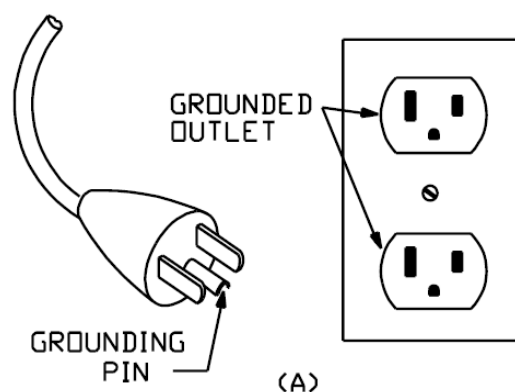

BATTERY INSTALLATION & REPLACEMENT

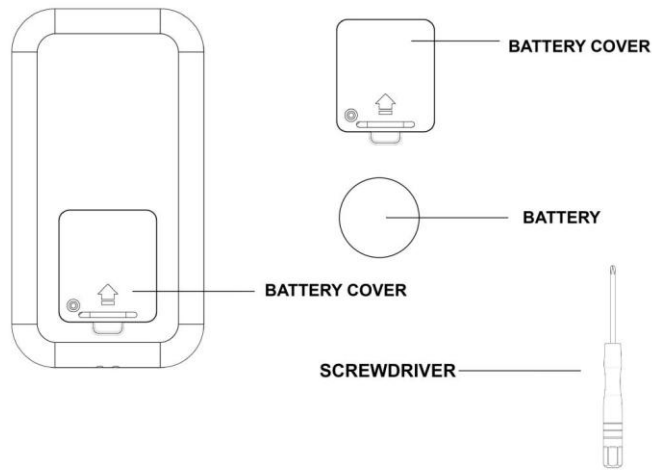

BATTERY INSTALLATION:

1. Use a **Screwdriver (No. B11)** to loosen and remove the screw from the battery cover.
2. Take out the CR2032 battery that is included inside the remote control box.
3. Install the battery into the battery holder with the positive end facing up.
4. Put the battery cover back on to the battery holder and lock the screw into the battery cover.

BATTERY REPLACEMENT:

1. Use a **Screwdriver (No. B11)** to loosen and remove the screw from the battery cover.
2. Remove the old battery and install the new battery into the battery holder with the positive pole facing up.
3. Put the battery cover back on to the battery holder and lock the screw into the battery cover.

Dispose of the old battery according to your regional guidelines.

Model: RC2302

Product Name: REMOTE CONTROL RC2302

FCC& IC Radiation Exposure Statement:

This equipment complies with FCC and Canada radiation exposure limits set forth for an uncontrolled environment.

This transmitter must not be co-located or operating in conjunction with any other antenna or transmitter.

THE DISPLAY CONSOLE

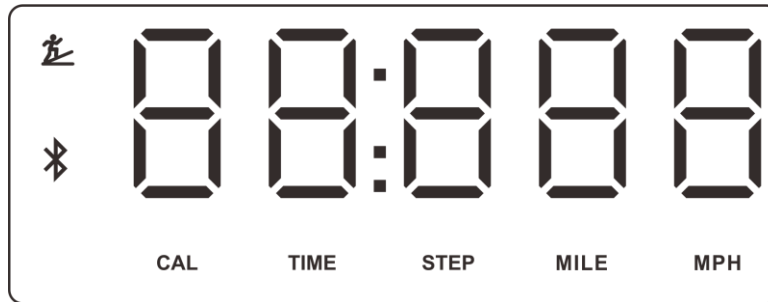

WINDOW DISPLAY:

Displays incline, calories, time, steps, distance and speed value in turn every 5 seconds.

INCLINE (🚶): Displays the incline from 0-6 level.

CALORIES (CAL): Displays the number of calories burned from 0 to 99999 KCAL. When the count reaches 99999 KCAL, it will reset and start back from 0.

TIME: Displays the time elapsed (0:00-99:59 MINS). If the time reaches 99:59, the treadmill will stop smoothly and display “End” then automatically reset to 0:00 after 5 seconds.

STEP: Displays the number of steps from 0 to 99999. When the count reaches 99999, it will reset and start back from 0.

DISTANCE (MILE): Displays the distance traveled (0.00-99.99). When the distance reaches 99.99 MILE, it will reset to 0.00 and begin counting again from 0.00.

SPEED (MPH): The folding upright tube can switch between the walking mode and the running mode; When folding or upright the machine, the system will release a beeping sound and the treadmill will stop; When the handrails lie down, the treadmill is walking mode. The speed range is **0.5-3.7 MPH**; when the handrails stand up, the treadmill is running mode. The speed range is **0.5-6.0 MPH**. 0.5MPH is the default running speed.

Note: When no person is running on the machine, distance and calories will not count.

When connecting to the App, the light of Bluetooth will light up.

PROGRAMS	Initial	Default Value	Set Range	Display Range
TIME (MIN:SECOND)	0:00	N/A	N/A	0:00—99:59
SPEED (MPH)	0.0	0.5	0.5-3.7(WALKING) 0.5-6 (RUNNING)	0.5-3.7(WALKING) 0.5-6 (RUNNING)
INCLINE	0	0	0-6	0-6
DISTANCE (MILE)	0.00	N/A	N/A	0.00-99.99
STEP	0	N/A	N/A	0-99999
CALORIE (KCAL)	0	N/A	N/A	0-99999

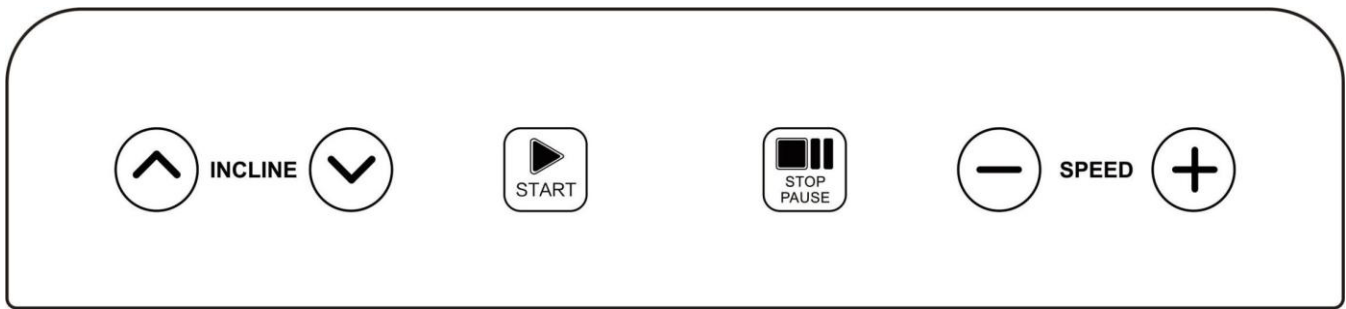

FUNCTION KEYS:

START: To start the treadmill, insert the pin end of the **Safety Key (No. E09)** into the **Motor Top Cover (No. C01)** and then press the START button. This treadmill requires the **Safety Key (No. E09)** in order to start. 0.5 MPH is the default start speed.

STOP/PAUSE: This button has functions of PAUSE and STOP. When in use, press this button once to PAUSE your workout and the current workout data will still be shown. Press STOP again to terminate your workout session completely and all data will be deleted and reset to the initial setting.

SPEED +/-: Press the +/- buttons to increase or decrease the speed in increments of 0.1 MPH. Pressing and holding either of these buttons for a duration of over ½ of a second will increase or decrease the speed continually.

INCLINE +/-: Press the +/- buttons to increase or decrease the incline in increments of 1. Pressing and holding either of these buttons for a duration of over ½ of a second will increase or decrease the incline continually.

REMOTE CONTROL FUNCTIONS:

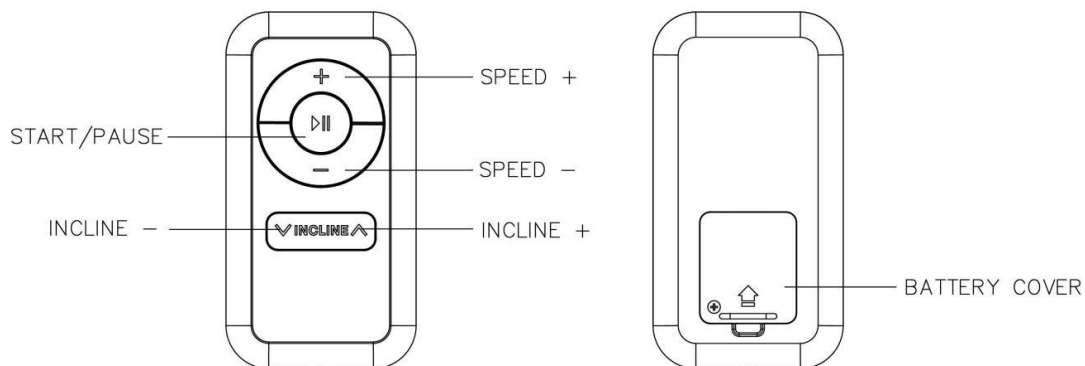

- START/PAUSE:** This button has functions of START and PAUSE. During walking, press the button once, the treadmill will pause, all data will be kept, and the window display will show "PAU". Under PAUSE mode, if press the button again, the treadmill will resume, and all data will continue to calculate. By holding the button for 2 seconds, the treadmill will stop and all workout data will reset back to initial settings.
- SPEED +/-:** Press the +/- buttons to increase or decrease the speed in increments of 0.1 MPH (Miles per hour). Pressing and holding either of these buttons for a duration of over ½ a second will increase or decrease the speed continually.
- INCLINE +/-:** Press the +/- buttons to increase or decrease the incline in increments of 1. Pressing and holding either of these buttons for a duration of over ½ a second will increase or decrease the incline continually.

Note: If the treadmill does not respond to the remote control, you will need to resync the treadmill and remote control. Please take the following steps to resync:

1. Hold the remote right next to the screen the entire time while resyncing.
2. Plug in the treadmill (do not turn it on).
3. Press and hold the start/pause button.
4. While keeping the button pressed, turn on the treadmill.
5. Continue to hold the button pressed for additional 5-10 seconds. If resync is successful, you will hear “beep--beep--” sound.
6. Release the button and try to control the treadmill functions using the remote.

NOTE:

When in walking mode, the maximum speed on this treadmill is 3.7 MPH (Miles per hour).

When in running mode, the maximum speed on this treadmill is 6 MPH (Miles per hour).

LUBRICATION REMINDER:

Your treadmill needs lubrication maintenance every 188 Miles. The system will release a beeping sound every 10 seconds and display an “OIL” icon on your display to remind you when it’s time. Please read the LUBRICATING THE TREADMILL on *Page 10* to learn the proper steps to lubricate your treadmill. Apply the lubricant to the middle of the running board on both sides. After application, press and hold the STOP button for 3 seconds to clear the “OIL” reminder.

SAFETY KEY FUNCTION:

Removing the **Safety Key (No. E09)** from the **Motor Top Cover (No. C01)** while the treadmill is running will cause it to stop immediately. Once the treadmill reaches a full stop, the window display of the console will show “- - -” and the speaker will beep 3 times. To start the treadmill again, insert the pin end of the **Safety Key (No. E09)** into the **Motor Top Cover (No. C01)** and press the START button.

POWER SAVE FUNCTION:

When the treadmill has been inactive for 10 minutes, it will enter Power Saving Mode. While the treadmill is in this mode, the window display of the **Motor Top Cover (No. C01)** will be turned off. To turn it back on, press any button.

Note: The machine will stop automatically after 15 minutes, if not in use.

I POWER ON:

Flick the power switch to this symbol to turn on the treadmill.

O POWER OFF:

Flick the power switch to this symbol to turn the treadmill off at any time. This includes during exercise.

SAFETY NOTE:

We recommend that you maintain a slow speed at the beginning of a session and hold the **Motor Top Cover (No. C01)** handrails until you have become familiar with the treadmill.

TECHNICAL DATA

Connectivity: Bluetooth LE

Frequency Range: 2400~2483.5Mhz

Transmitting Power: 0dBm

EXERCISE INSTRUCTIONS

GETTING STARTED:

Before starting any exercise program, you should consult your physician to determine if you have any medical or physical conditions that could put your health and safety at risk or prevent you from using the equipment properly.

Be aware of your body's signals. Incorrect or excessive exercise can damage your health. Stop exercising immediately if you experience any of the following symptoms: pain, tightness in your chest, irregular heartbeat, shortness of breath, lightheadedness, dizziness, or feelings of nausea.

Get to know your treadmill. Before attempting to use the treadmill take some time to stand alongside and familiarize yourself with the controls.

1. Once you get on, you can stand with your feet on the **Side Rails (No. C09)** and stabilize yourself by holding onto the handrails.
2. Next, attach the pin end of the **Safety Key (No. E09)** to your clothes and insert the pin end of the **Safety Key (No. E09)** into the **Motor Top Cover (No. C01)**.
3. Press the START button to start the treadmill.
4. The treadmill will start at the system default setting speed of **0.5MPH**. When you feel comfortable, you may slowly increase this speed.
5. When you are finished with your exercise, press the STOP button to stop the treadmill or you can remove the pin end of the **Motor Top Cover (No. C01)** to stop the treadmill.

APP CONNECTION:

Connect Smart Equipment to SunnyFit App:

1. Scan to download SunnyFit from the app store:



2. Ensure that the Bluetooth function is turned on from your mobile device.
3. If this is your first time using the SunnyFit app, follow the in-app instructions to register for your free SunnyFit account and log in.
4. Begin any workout activity that matches your smart equipment, then follow the onscreen prompts to search for and connect to your smart equipment.
5. When connected, your stats and records will be displayed at the end of your course/session, and recorded in your account profile!

TROUBLESHOOTING

PROBLEM	POSSIBLE CAUSE	SUGGESTED ACTION
Treadmill will not start	Not plugged in.	Plug cord into outlet.
	Safety Key is not inserted.	Insert Safety Key.
Running belt not centered	Running belt tension is not correct on the left or right sides of the running board.	Tighten the left and right adjusting bolts of the rear roller.
Computer not working	Wires from the console and bottom control board are not properly connected.	Check wire connections from the console to the bottom control board.
	Transformer is damaged.	If the transformer is damaged, contact customer service.
E01 or E13: Message failure	Wires from the console and bottom control board are not properly connected.	Check wire connections from the console to the bottom control board. If the wire has been punctured or damaged, you will need to replace it. If the problem is not rectified, you may need to replace the control board.
E02: Burst clash protection	Incoming voltage is lower than 50% of the required voltage.	Check that the incoming power supply is the correct voltage. Check the control board and motor, replace if damaged.
E04: Incline failure	The incline motor is damaged or the wire for the incline motor is not connected properly or has become damaged	Re-connect or replace the wire for the incline motor. Replace the incline motor with a new one if damaged. Check the control board, replace if damaged. Press incline self-inspection button of the control board once replace a new control board or a new motor.

E05: Current overload protection (Self Protecting System)	The incoming voltage is too low or too high. The control board is damaged.	Press the Overload Protector (No. E14) to restart the treadmill. Restart the treadmill. Check the incoming voltage to ensure it is correct. Check the control board, replace if damaged.
	A moving part of the treadmill is stuck and therefore, the motor is unable to rotate properly.	Inspect moving parts of the treadmill to ensure that they are operating correctly. Check the motor, listen for strange noise and check for a burning smell. Replace the motor if necessary.
E06: Motor Abnormality	The motor wire is not connected, or the motor is damaged.	Check motor wires to see if the motor is connected. If the wire has been punctured or damaged, you will need to replace it. If the problem is not rectified, you may need to replace the motor.
E08: Error storing 24C02	Something wrong of IC	Re-insert the storage IC to IC base, replace the control board if necessary.
E10: Motor Abnormality	The motor is damaged, or a moving part of the treadmill is stuck and therefore the motor is unable to rotate properly.	Inspect moving parts of the treadmill to ensure that they are operating correctly. Add the lubrication oil. Replace the motor if necessary.

NOTE:

1. If you are having trouble connecting your smart equipment, visit www.sunnyfit.com/guide or scan the QR code below:



2. If you require additional support, please contact support@sunnyfit.com.

EXPLODED DIAGRAM 1

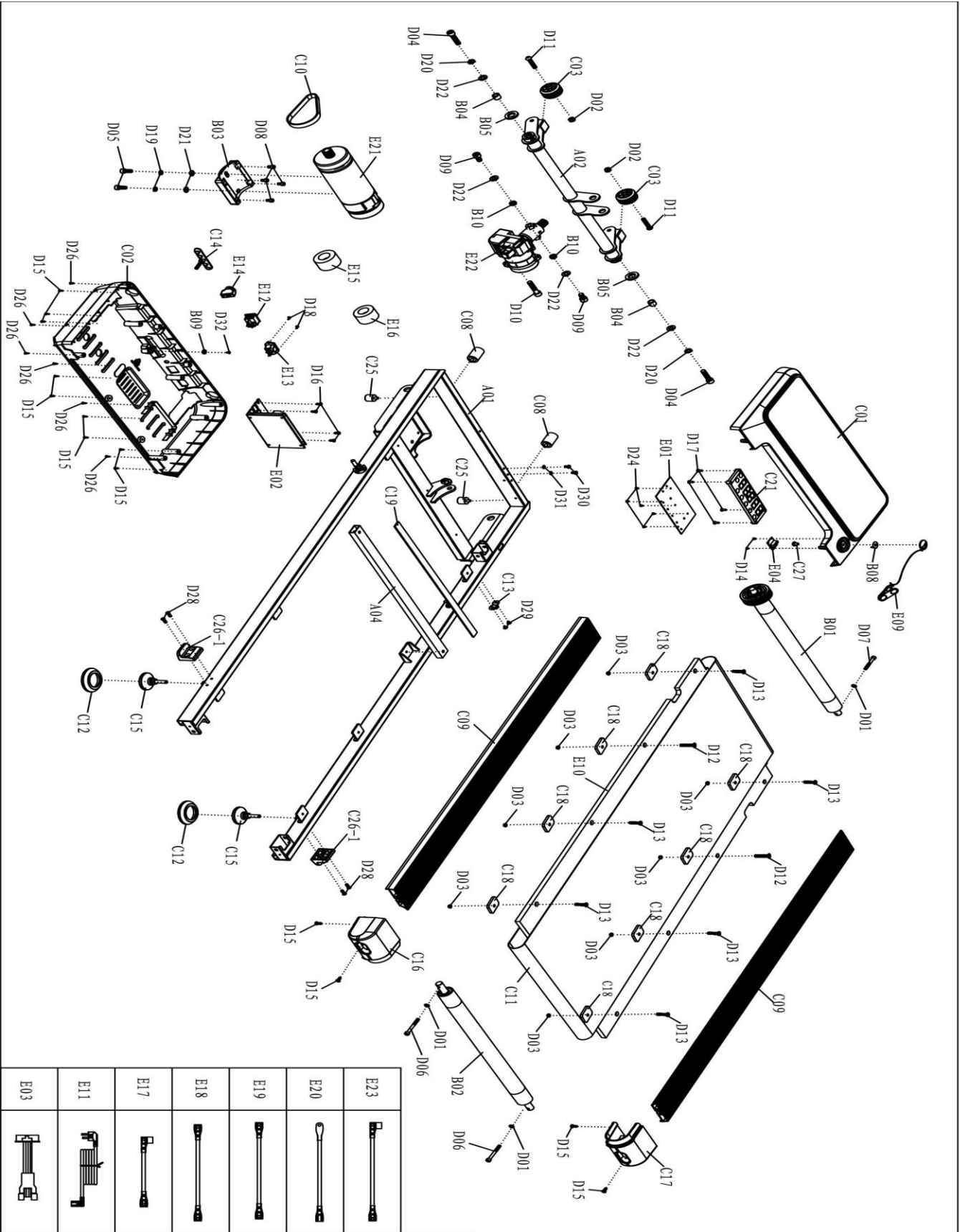

EXPLODED DIAGRAM 2

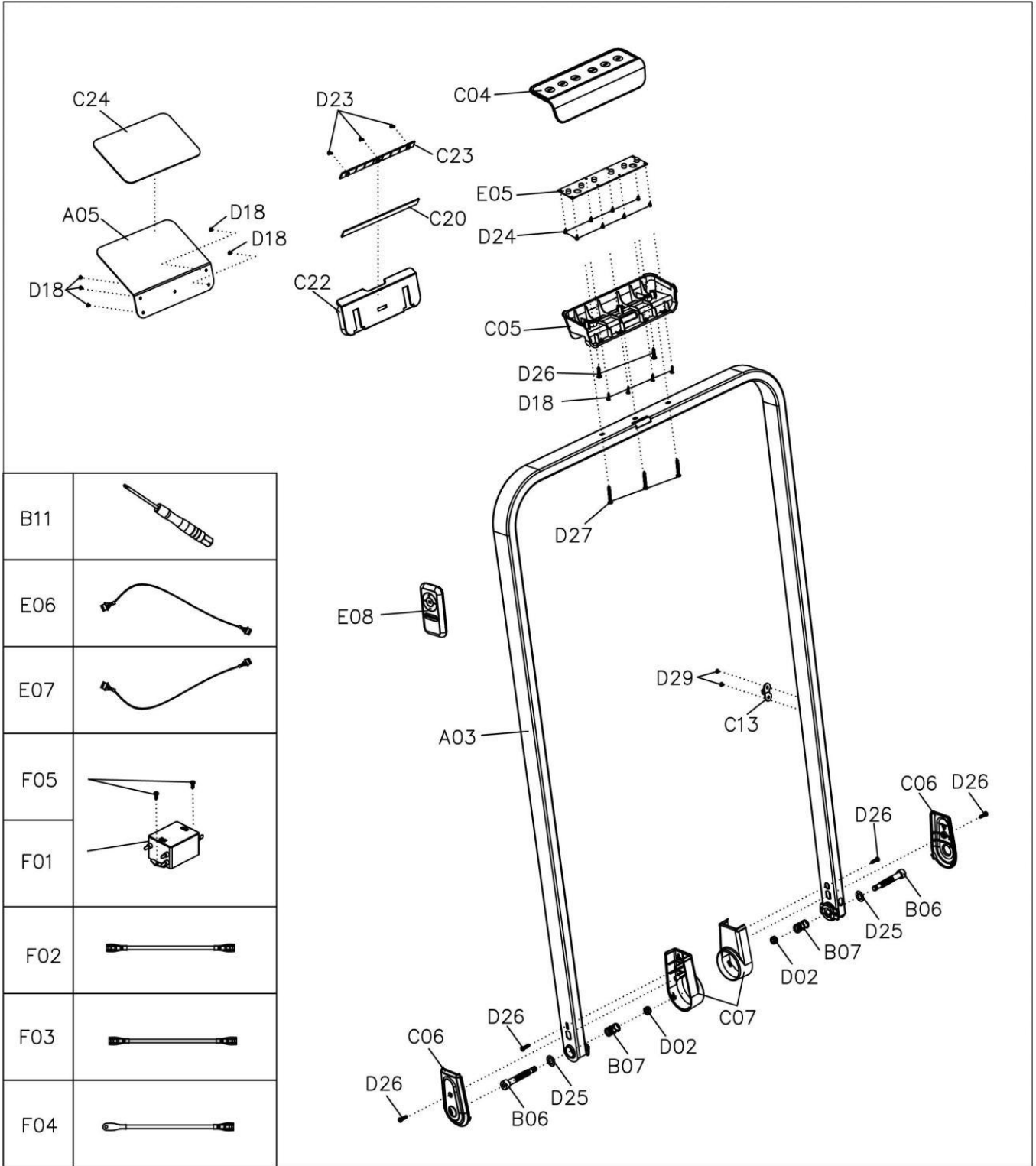

B11	
E06	
E07	
F05	
F01	
F02	
F03	
F04	

PARTS LIST

No.	Description	Specification	Qty.
A01	Main Frame		1
A02	Incline Frame		1
A03	Upright Tube		1
A04	Running Board Strength Rod		1
A05	Tablet Holder Base		1
B01	Front Roller		1
B02	Rear Roller		1
B03	Motor Fixed Base		1
B04	Turning Sleeve		2
B05	Bearing		2
B06	Screw		2
B07	Spring		2
B08	Safety Key Plate		1
B09	Magnet		1
B10	Incline Rotating Pipe		2
B11	Screwdriver		1
C01	Motor Top Cover		1
C02	Motor Bottom Cover		1
C03	Transport Wheel		2
C04	Tablet Holder Top Cover		1
C05	Tablet Holder Bottom Cover		1
C06	Upright Tube Outer Cover		2
C07	Upright Tube Inner Cover		2
C08	Black Cushion		2
C09	Side Rail		2
C10	Motor Belt		1
C11	Running Belt		1
C12	Foot Pad Sucker		2
C13	Lead Wire Buckle		2
C14	T-Shape Wrench		1
C15	Universal Foot Pad Set		2
C16	Left Rear Cover		1
C17	Right Rear Cover		1
C18	Rubber Cushion		8
C19	Big Cushion		1

No.	Description	Specification	Qty.
C20	EVA Pad		1
C21	Grating Plate		1
C22	Tablet Holder Fixed Base		1
C23	Tablet Holder Cover		1
C24	Tablet Holder Mat		1
C25	Cushion		2
C26-1	Upright Tube Limited Base		2
C27	Safety Key Ball		1
D01	Locked Washer	Φ6	3
D02	Nut	M8	4
D03	Nut	M6	8
D04	Bolt	M10*40	2
D05	Bolt	M8*20	2
D06	Bolt	M6*55	2
D07	Cylindrical Head Bolt	M6*45	1
D08	Bolt	M6*10	4
D09	Bolt	M10*15	2
D10	Bolt	M10*40	1
D11	Bolt	M8*45	2
D12	Countersunk Head Bolt	M6*45	2
D13	Bolt	M6*27	6
D14	Screw	ST2.5*6	2
D15	Screw	ST4.2*16	13
D16	Screw w/ Washer	ST4.2*12	4
D17	Pan Head Tapping Screw	ST2.9*8	4
D18	Countersunk Head Screw	ST2.9*8	11
D19	Spring Washer	Φ8	2
D20	Spring Washer	Φ10	2
D21	Flat Washer	Φ8	2
D22	Flat Washer	Φ10	4
D23	Screw	ST2.5*6	3
D24	Screw	ST2.9*6	13
D25	Locking Washer	Φ10	2
D26	Screw	ST4.2*16	12
D27	Screw	ST4.2*35 Nickel plating	3

No.	Description	Specification	Qty.
D28	Bolt	M5*20	4
D29	Screw	ST4.2*12	4
D30	Bolt	M5*12	2
D31	Locking Washer	Φ5	2
D32	Screw	ST2.9*8	1
E01	Display		1
E02	Control Board		1
E03	Communication Wire		1
E04	Speed Wire		1
E05	Button Board		1
E06	Button Board Top Wire		1
E07	Button Board Bottom Wire		1
E08	Remote Control		1
E09	Safety Key		1
E10	Running Board		1
E11	Power Wire		1
E12	Square Switch		1

No.	Description	Specification	Qty.
E13	Power Socket		1
E14	Overload Protector		1
E15	Magnet Ring	Φ 16* Φ 28*28	1
E16	Magnet Ring	Φ 25* Φ 15*12	1
E17	AC Signal Wire	Brown 200	1
E18	AC Signal Wire	Brown 350	1
E19	AC Signal Wire	Blue 350	1
E20	Ground Wire		1
E21	DC Motor		1
E22	Incline Motor		1
E23	AC Signal Wire	Brown 350 90 degree bend	1
F01	Filter		1
F02	AC Signal Wire	Blue 450	1
F03	AC Signal Wire	Brown 450	1
F04	Ground Wire		1
F05	Screw	ST4.2*12	2

Version 2.0

CONNECT
with us

DOWNLOAD

Track your fitness progress & join
FREE workout courses!

Download  **SUNNYFIT** today!



FOLLOW

Find us on social media @sunnyhealthfitness

 @sunnyhealthfitness

 @sunnyhealthandfitness

 @sunnyhealthfit

 /sunnyhealthfitness

 /sunnyhealthfitness

 /sunnyhealthandfitness

www.sunnyhealthfitness.com