

Dell 16

DC16250

Owner's Manual

Notes, cautions, and warnings

 **NOTE:** A NOTE indicates important information that helps you make better use of your product.

 **CAUTION:** A CAUTION indicates either potential damage to hardware or loss of data and tells you how to avoid the problem.

 **WARNING:** A WARNING indicates a potential for property damage, personal injury, or death.

Chapter 1: Views of Dell 16 DC16250	7
Right	7
Left	7
Top	8
Front	9
Bottom	10
Locate the Service Tag or Express Service Code label of your computer	10
Battery-status light	11
Chapter 2: Set up your Dell 16 DC16250	12
Chapter 3: Specifications of Dell 16 DC16250	14
Dimensions and weight	14
Processor	14
Chipset	15
Operating system	15
Memory	16
External ports and slots	16
Internal slots	17
Wireless module	17
Audio	17
Storage	18
Keyboard	18
Keyboard shortcuts of Dell 16 DC16250	19
Camera	20
Touchpad	21
Power adapter	21
Power adapter requirements of Dell 16 DC16250	22
Battery	22
Power requirements (for computers shipped with 3-cell, 41 Wh battery)	23
Power requirements (for computers shipped with 4-cell, 54 Wh battery)	23
Display	24
Fingerprint reader (optional)	25
Sensors	25
GPU—Integrated	25
External display support	25
GPU—Discrete	26
External display support	26
Hardware security	26
Operating and storage environment	26
Dell support policy	27
ComfortView	27
Dell Optimizer	27

Chapter 4: Working inside your computer.....	28
Safety instructions.....	28
Before working inside your computer.....	28
Safety precautions.....	29
Electrostatic discharge—ESD protection.....	29
ESD Field Service kit	30
Transporting sensitive components.....	31
After working inside your computer.....	31
Information on reparability for Québec - From Dell Canada Inc. - to Quebec consumers.....	31
BitLocker.....	31
Recommended tools.....	32
Screw list.....	32
Major components of Dell 16 DC16250.....	33
Chapter 5: Removing and installing Customer Replaceable Units (CRUs).....	36
Base cover.....	36
Removing the base cover.....	36
Installing the base cover	38
Battery.....	40
Rechargeable Li-ion battery precautions.....	40
Removing the 3-cell battery	41
Installing the 3-cell battery	42
Removing the 4-cell battery	43
Installing the 4-cell battery	44
Battery cable.....	46
Disconnecting the battery cable	46
Connecting the battery cable	47
Memory module.....	48
Removing the memory module	48
Installing the memory module	49
Solid state drive.....	51
Removing the solid state drive	51
Installing the solid state drive	51
Wireless card.....	52
Removing the wireless card	52
Installing the wireless card	53
Speakers.....	55
Removing the speakers	55
Installing the speakers	57
Fan.....	59
Removing the fan	59
Installing the fan	60
Chapter 6: Removing and installing Field Replaceable Units (FRUs).....	62
Heat sink.....	62
Removing the heat sink - for computers shipped with integrated graphics card.....	62
Installing the heat sink - for computers shipped with integrated graphics card.....	63
Removing the heat sink - for computers shipped with discrete graphics card.....	64

Installing the heat sink - for computers shipped with discrete graphics card.....	65
Touchpad.....	67
Removing the touchpad.....	67
Installing the touchpad	68
I/O-board cable	70
Removing the I/O-board cable.....	70
Installing the I/O-board cable.....	70
I/O board.....	71
Removing the I/O board	71
Installing the I/O board	72
Display assembly.....	73
Removing the display assembly	73
Installing the display assembly	75
Display bezel.....	77
Removing the display bezel	77
Installing the display bezel	82
Display panel.....	84
Removing the display panel	84
Installing the display panel	87
Display cable.....	90
Removing the display cable	90
Installing the display cable	91
Camera.....	92
Removing the camera	92
Installing the camera	92
Display back-cover and antenna assembly.....	93
Removing the display back-cover and antenna assembly	93
Installing the display back-cover and antenna assembly	94
Power button.....	95
Removing the power button	95
Installing the power button	96
Power button with fingerprint reader.....	97
Removing the power button with fingerprint reader	97
Installing the power button with fingerprint reader	98
Power-adapter port.....	100
Removing the power-adapter port	100
Installing the power-adapter port	101
System board.....	102
Removing the system board	102
Installing the system board	106
Palm-rest and keyboard assembly.....	110
Removing the palm-rest and keyboard assembly	110
Installing the palm-rest and keyboard assembly	111
Chapter 7: Software.....	114
Operating system.....	114
Drivers and downloads.....	114
Chapter 8: BIOS Setup.....	115

Entering BIOS Setup program.....	115
Navigation keys.....	115
F12 One Time Boot menu.....	115
System setup options.....	116
Updating the BIOS.....	120
Updating the BIOS in Windows.....	120
Updating the BIOS using the USB drive in Windows.....	120
Updating the BIOS in Linux and Ubuntu.....	121
Updating the BIOS from the One-Time boot menu.....	121
System and admin password.....	121
Assigning a System Setup password.....	121
Deleting or changing an existing system password or admin password.....	122
Clearing system and admin passwords.....	122
Chapter 9: Troubleshooting.....	123
Handling swollen rechargeable Li-ion batteries.....	123
Dell SupportAssist Pre-boot System Performance Check diagnostics.....	123
Running the SupportAssist Pre-Boot System Performance Check.....	124
Built-in self-test (BIST).....	124
Motherboard Built-In Self-Test (M-BIST).....	124
Logic Built-in Self-test (L-BIST).....	125
LCD Built-in Self-Test (LCD-BIST).....	125
System-diagnostic lights.....	125
Recovering the operating system.....	126
Real-Time Clock (RTC Reset).....	127
Backup media and recovery options.....	127
Network power cycle.....	127
Drain flea power (perform hard reset).....	127
Chapter 10: Getting help and contacting Dell.....	129
Chapter 11: Revision history.....	130

Views of Dell 16 DC16250

Right



Figure 1. Right view

1. **Universal Audio port**

Connect headphones or a headset (headphone and microphone combo).

2. **USB 3.2 Gen 1 (5 Gbps) port**

Connect devices such as external storage devices and printers. Provides data transfer speeds of up to 5 Gbps.

3. **Security-cable slot (wedge-shaped)**

Connect a security cable to prevent unauthorized movement of your computer.

Left



Figure 2. Left view

1. **Power-adapter port**

Connect a power adapter to provide power to your computer and charge the battery.

2. **Battery-status light**

Indicates the battery-charge status.

- White—Battery is charging.
- Amber—Battery charge is low or critical.

3. **HDMI 1.4 port**

Connect to a TV, external display, or another HDMI-in enabled device. Provides video and audio output.

4. USB 3.2 Gen 1 (5 Gbps) port

Connect devices such as external storage devices and printers. Provides data transfer speeds of up to 5 Gbps.

5. USB 3.2 Gen 2 (10 Gbps) Type-C port with DisplayPort 1.4 and Power Delivery

Connect devices such as external storage devices, printers, and external displays. Provides data transfer rate of up to 10 Gbps.

Supports Power Delivery that enables two-way power supply between devices. Provides up to 15 W power output to enable faster charging.

NOTE: A USB Type-C to DisplayPort adapter (sold separately) is required to connect a DisplayPort device.

Top



Figure 3. Top view

1. Power button with optional fingerprint reader

Press to turn on the computer if it is turned off, in sleep state, or in hibernate state.

When the computer is turned on, press the power button to put the computer into a sleep state; press and hold the power button for 10 seconds to force shut-down the computer.

If the power button has a fingerprint reader, place your finger on the power button steadily to log in.

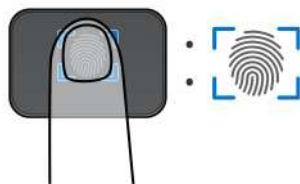

Figure 4. Active area of the fingerprint reader

NOTE: The highlighted area indicates the actual active fingerprint reader area, and the image is for illustration purposes only.

NOTE: You can customize the power-button behavior in Windows. For more information, see [Dell Support Site](#).

2. Precision touchpad

Move your finger on the touchpad to move the mouse pointer. Tap to left-click and two fingers tap to right-click.

Front

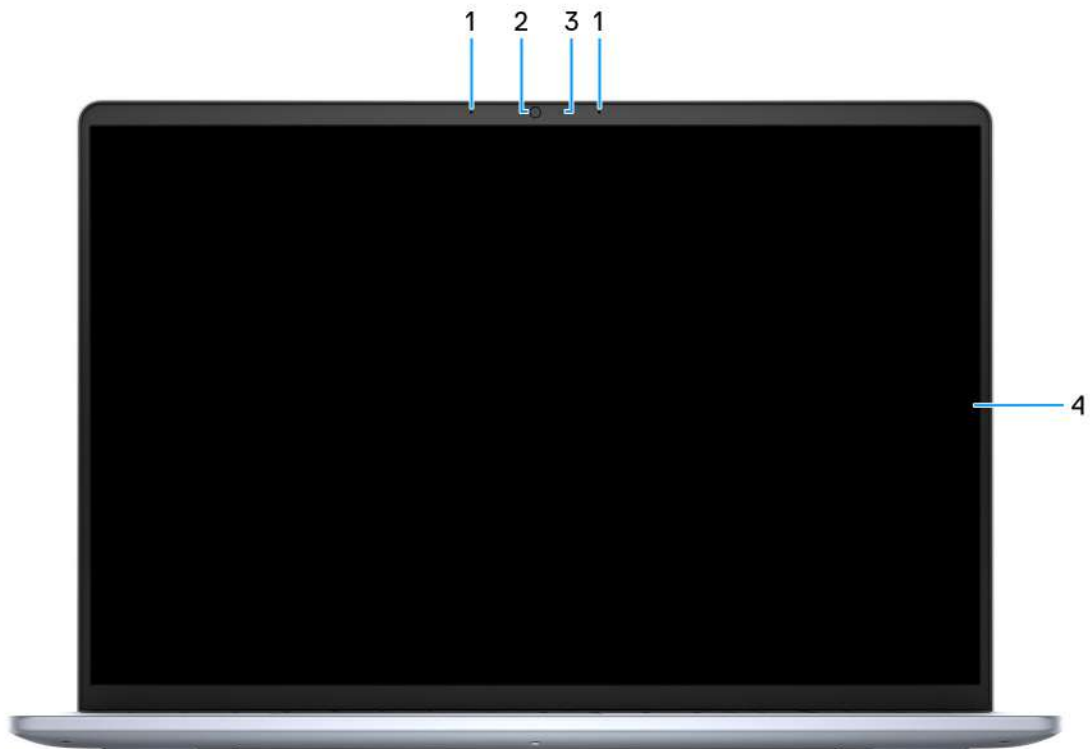

Figure 5. Front view

1. Left and right microphones

Provides digital sound input for audio recording and voice calls.

2. Camera

Enables you to video chat, capture photos, and record videos.

3. Camera-status light

Turns on when the camera is in use.

4. Display

Provides visual output.

Bottom

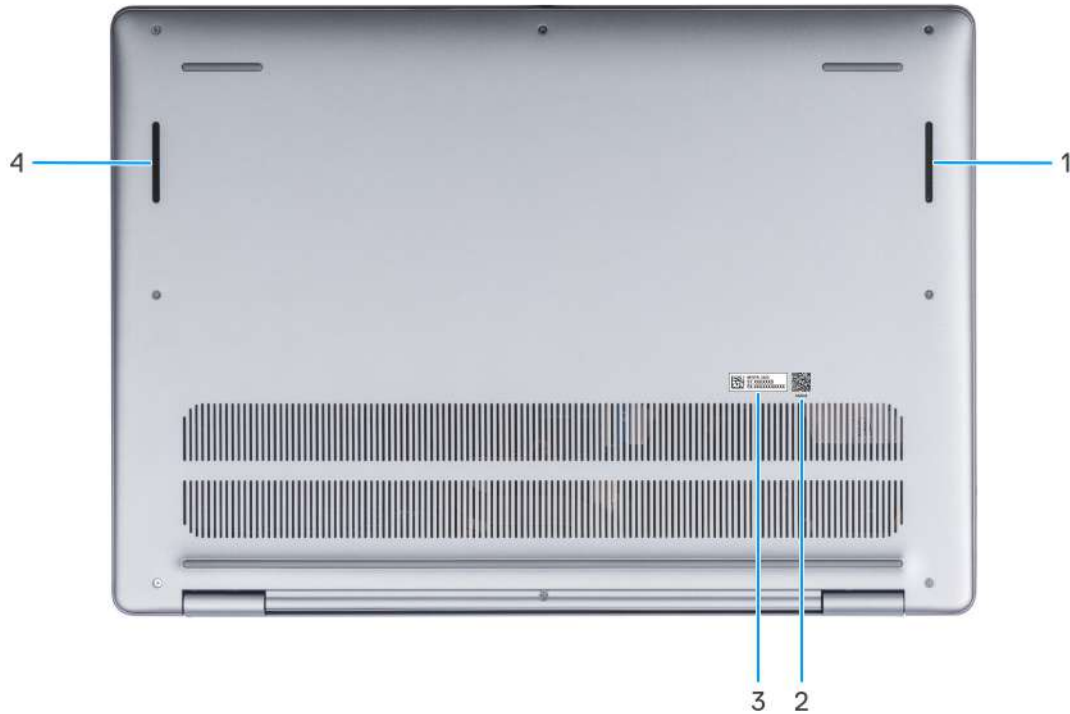

Figure 6. Bottom view

1. Right speaker

Provides audio output.

2. MyDell QR code

MyDell is your hub for content personalized to your Dell 16 DC16250, including videos, articles, manuals, and access to support.

3. Service Tag label

The Service Tag is a unique alphanumeric identifier that enables Dell service technicians to identify the hardware components in your computer and access warranty information.

4. Left speaker

Provides audio output.

Locate the Service Tag or Express Service Code label of your computer

The Service Tag is a unique alphanumeric identifier that allows Dell service technicians to identify the hardware components in your computer and access warranty information. The Express Service Code is a numeric version of the Service Tag.

For more information about how to find the Service Tag of your computer, search in the Knowledge Base Resource at the [Dell Support Site](#).

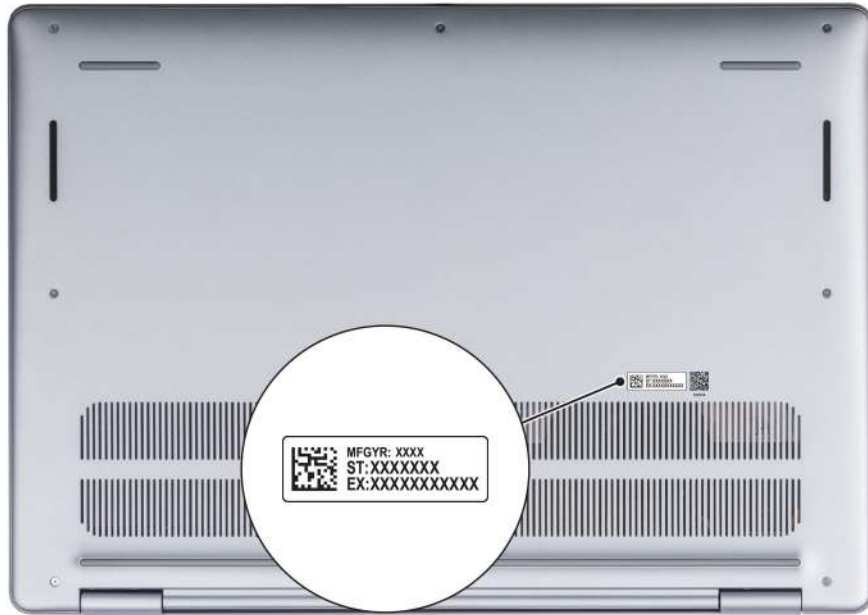

Figure 7. Service Tag/Express Service Code location

Battery-status light

The following table lists the battery-status light of your Dell 16 DC16250.

Table 1. Battery-status light behavior

Power source	LED behavior	System power state	Battery charge level
AC adapter	Off	S0 or S5	100%
AC adapter	Solid white	S0 or S5	< 100%
Battery	Off	S0 or S5	11-100%
Battery	Solid amber	S0 or S5	< 10%

- S0 (ON): The computer is turned on.
- S3 (Sleep): Screen is off and computer is in sleep mode.
- S4 (Hibernate): The computer consumes the least power in the Hibernate state than in the ON or OFF state. The computer is almost in the OFF state. The context data is written to a storage device, allowing you to resume from where you left after the computer is turned on.
- S5 (OFF): The computer is in a shutdown state.

Set up your Dell 16 DC16250

About this task

NOTE: The images in this document may differ from your computer depending on the configuration you ordered.

Steps

1. Connect the power adapter and press the power button.



Figure 8. Connect the power adapter and press the power button

NOTE: The battery may go into power-saving mode during shipment to conserve charge on the battery. Ensure that the power adapter is connected to your computer when it is turned on for the first time.

2. Finish the operating system setup.

For Ubuntu:

Follow the on-screen instructions to complete the setup. For more information about installing and configuring Ubuntu, search in the Knowledge Base Resource at [Dell Support Site](#).

For Windows:

Follow the on-screen instructions to complete the setup. When setting up, it is recommended that you:





- Connect to a network for Windows updates.

NOTE: If connecting to a secured wireless network, enter the password for the wireless network access when prompted.

- If connected to the Internet, sign-in with an existing Microsoft account or create an account. If not connected to the Internet, create an offline account.
- On the **Support and Protection** screen, enter your contact details.

3. Locate and use Dell apps from the Windows Start menu—Recommended.

Table 2. Locate Dell apps

Resources	Description
	<p>Dell Optimizer is an application designed to enhance computer performance and productivity by optimizing settings for power, battery, display, collaboration touchpad, and presence detection. It also provides access to applications purchased with your new computer.</p> <p>For more information, see Dell Optimizer User's Guide at Dell Support Site.</p>
	<p>Dell Product Registration</p> <p>Register your computer with Dell.</p>
	<p>Dell Help & Support</p> <p>Access help and support for your computer.</p>
	<p>SupportAssist</p> <p>SupportAssist is a proactive and predictive technology that offers automated technical support for Dell computers. It proactively monitors both hardware and software, addressing performance issues, preventing security threats, and automating engagement with Dell Technical Support.</p> <p>For more information, see SupportAssist for Home PCs User's Guide at Dell Support Site.</p> <p>NOTE: In SupportAssist, click the warranty expiry date to renew or upgrade your warranty.</p>

Specifications of Dell 16 DC16250

Dimensions and weight

The following table lists the height, width, depth, and weight of your Dell 16 DC16250.

Table 3. Dimensions and weight

Description	Values
Height:	
Front height	16.74 mm (0.65 in.)
Rear height	18.23 mm (0.72 in.)
Width	357.30 mm (14.06 in.)
Depth	250.60 mm (9.86 in.)
Weight  NOTE: The weight of your computer depends on the configuration that you ordered.	<ul style="list-style-type: none"> • Minimum: 1.88 kg (4.15 lb) • Maximum: 2 kg (4.40 lb)

Processor

The following table lists the details of the processors that are supported in your Dell 16 DC16250.

Table 4. Processor

Description	Option one	Option two
Processor type	Intel Core 7 150U	Intel Core 5 120U
Processor wattage	15 W	15 W
Processor total core count	10	10
Performance-cores	2	2
Efficient-cores	8	8
Processor total thread count  NOTE: Intel Hyper-Threading Technology is only available on Performance-cores.	12	12
Processor speed	1.8 GHz to 5.4 GHz	1.4 GHz to 5 GHz
Frequency—Performance cores		
Processor base frequency	1.8 GHz	1.4 GHz
Maximum turbo frequency	5.4 GHz	5 GHz

Table 4. Processor (continued)

Description		Option one	Option two
Frequency—Efficient cores			
	Processor base frequency	1.8 GHz	1.4 GHz
	Maximum turbo frequency	3.8 GHz	3.6 GHz
Thermal Mode/Thermal Design Power (TDP)			
	Cool	10 W	10 W
	Optimized	15 W	15 W
	Quiet	10 W	10 W
	Ultra Performance	17 W	17 W
Processor cache		12 MB	12 MB
Integrated graphics		Intel Graphics	Intel Graphics

Chipset

The following table lists the details of the chipset that is supported by your Dell 16 DC16250.

Table 5. Chipset

Description	Values
Chipset	Integrated
Processor	Intel Core 5/7 processors
DRAM bus width	Two channels, 64-bit
Flash EPROM	32 MB
PCIe bus	Up to Gen4

Operating system

Your Dell 16 DC16250 supports the following operating systems:

- Windows 11 Pro
- Windows 11 Pro National Education
- Windows 11 Home
- Windows 11 Home (S Mode)
- Ubuntu Linux 24.04 LTS, 64-bit

Memory

The following table lists the memory specifications that are supported by your Dell 16 DC16250.

Table 6. Memory specifications

Description	Values
Memory slots	Two SODIMM slots
Memory type	DDR5
Memory speed	5200 MT/s
Maximum memory configuration	32 GB
Minimum memory configuration	8 GB
Memory size per slot	8 GB or 16 GB
Memory configurations supported	<ul style="list-style-type: none">• 8 GB: 1 x 8 GB, DDR5, 5200 MT/s, single-channel• 16 GB: 2 x 8 GB, DDR5, 5200 MT/s, dual-channel• 24 GB: 1 x 16 GB + 1 x 8 GB, DDR5, 5200 MT/s, dual-channel• 32 GB: 2 x 16 GB, DDR5, 5200 MT/s, dual-channel

External ports and slots

The following table lists the external ports and slots on your Dell 16 DC16250.

Table 7. External ports and slots

Description	Values
USB ports	<ul style="list-style-type: none">• Two USB 3.2 Gen 1 (5 Gbps) ports• One USB 3.2 Gen 2 (10 Gbps) Type-C port with DisplayPort 1.4 and Power Delivery
Audio port	One Universal Audio port
Video port(s)	One HDMI 1.4 port  NOTE: The maximum resolution supported over HDMI 1.4 port is 1920 x 1080 at 60 Hz. No 4K/2K output.
Media-card reader	Not supported
Power-adaptor port	One 65 W DC-in adapter, 4.50 mm barrel, E4
Security-cable slot	One wedge-shaped lock slot

Internal slots

The following table lists the internal slots of your Dell 16 DC16250.

Table 8. Internal slots

Description	Values
M.2	<ul style="list-style-type: none"> One M.2 2230 slot for Wi-Fi and Bluetooth combo card One M.2 2230 slot for solid state drive <p> NOTE: To learn more about the features of different types of M.2 cards, search Dell Support Site.</p>

Wireless module

The following table lists the Wireless Local Area Network (WLAN) module that is supported on your Dell 16 DC16250.

Table 9. Wireless module specifications

Description	Values
Model number	Realtek RTL8852BE
Transfer rate	Up to 1201 Mbps
Frequency bands supported	2.4 GHz/5 GHz
Wireless standards	<ul style="list-style-type: none"> Wi-Fi 802.11a/b/g Wi-Fi 4 (Wi-Fi 802.11n) Wi-Fi 5 (Wi-Fi 802.11ac) Wi-Fi 6 (Wi-Fi 802.11ax)
Encryption	<ul style="list-style-type: none"> 64-bit/128-bit WEP AES-CCMP TKIP
Bluetooth wireless card  NOTE: The functionality of the Bluetooth wireless card may vary based on the operating system.	Bluetooth 5.3 wireless card

Audio

The following table lists the audio specifications of your Dell 16 DC16250.

Table 10. Audio specifications

Description	Values	
Audio controller	Realtek ALC3254	Realtek ALC3204
Stereo conversion	Supported	Supported
Internal audio interface	High definition audio interface	High definition audio interface
External audio interface	One Universal Audio port	One Universal Audio port
Number of speakers	Two	Two

Table 10. Audio specifications (continued)

Description		Values	
Internal-speaker amplifier		Supported	Supported
External volume controls		Keyboard shortcut controls	Keyboard shortcut controls
Speaker output:			
	Average	2 W x 2 = 4 W	2 W x 2 = 4 W
	Peak	2.5 W x 2 = 5 W	2.5 W x 2 = 5 W
Microphone		Dual-array microphones	Dual-array microphones

Storage

This section lists the storage options on your Dell 16 DC16250.

Your Dell 16 DC16250 supports only one M.2 2230 solid state drive.

 **NOTE:** The M.2 2230 solid state drive is the primary storage drive of your computer

Table 11. Storage specifications

Storage type	Interface type	Capacity
M.2 2230 solid state drive	Gen4 PCIe NVMe	Up to 2 TB

Keyboard

The following table lists the keyboard specifications of your Dell 16 DC16250.

Table 12. Keyboard specifications

Description	Values
Keyboard type	<ul style="list-style-type: none"> Standard backlit Copilot key keyboard Standard nonbacklit Copilot key keyboard
Keyboard layout	QWERTY
Number of keys	<ul style="list-style-type: none"> English International; English US; Arabic; Canada (Bilingual) (MUI); Chinese (Traditional); Greek; Hebrew; Korean; and Ukrainian: 99 keys Belgian; Bulgarian; Czech/Slovak (MUI); French (European); German; Hungarian; Italian; Nordic (MUI); Slovenian; Spanish (Castilian); Spanish (Latin American); Swiss/European (MUI); Turkish: 100 keys Japanese: 103 keys
Key pitch	X = 18.70 mm Y = 18.05 mm
Keyboard shortcuts	Some keys on your keyboard have two symbols on them. These keys can be used to type alternate characters or to perform secondary functions. To type the alternate character,

Table 12. Keyboard specifications (continued)

Description	Values
	press Shift and the desired key. To perform secondary functions, press Fn and the desired key.

Keyboard shortcuts of Dell 16 DC16250

NOTE: Keyboard characters may differ depending on the keyboard language configuration. Keys that are used for shortcuts remain the same across all language configurations.

Some keys on your keyboard have two symbols on them. These keys can be used to type alternate characters or to perform secondary functions. The symbol that is shown on the lower part of the key refers to the character that is typed out when the key is pressed. If you press shift and the key, the symbol that is shown on the upper part of the key is typed out. For example, if you press **2**, 2 is typed out; if you press **Shift + 2**, @ is typed out.

The keys F1-F12 at the top row of the keyboard are function keys for multimedia control, as indicated by the icon on the key. Press the function key to enable the task represented by the icon. For example, pressing F1 mutes the audio (see the table below).

However, if the function keys F1-F12 are needed for specific software applications, multimedia functionality can be disabled by pressing **Fn + Esc**. Later, multimedia control can be invoked by pressing **Fn** and the respective function key. For example, mute audio by pressing **Fn + F1**.

NOTE: You can also define the primary behavior of the function keys (F1–F12) by changing **Function Key Behavior** in the BIOS setup program.

Table 13. Function key primary behavior

Function key	Primary behavior
F1	Mute or unmute audio
F2	Decrease volume
F3	Increase volume
F4	Microphone Mute
F5	KB Illumination/Backlight
F6	Decrease brightness
F7	Increase brightness
F8	Switch to external display
F9	Stealth mode
F10	Print screen
F11	Home
F12	End

The **fn** key is also used with selected keys on the keyboard to invoke secondary functions.

Table 14. Secondary behavior

Function key	Secondary behavior
fn + F1	Operating system and application-specific F1 behavior
fn + F2	Operating system and application-specific F2 behavior
fn + F3	Operating system and application-specific F3 behavior
fn + F4	Operating system and application-specific F4 behavior
fn + F5	Operating system and application-specific F5 behavior

Table 14. Secondary behavior (continued)

Function key	Secondary behavior
fn + F6	Operating system and application-specific F6 behavior
fn + F7	Operating system and application-specific F7 behavior
fn + F8	Operating system and application-specific F8 behavior
fn + F9	Operating system and application-specific F9 behavior
fn + F10	Operating system and application-specific F10 behavior
fn + F11	Operating system and application-specific F11 behavior
fn + F12	Operating system and application-specific F12 behavior
fn + Ctrl	Open the application menu
fn + Esc	Toggle between multimedia and function key behavior
fn + PgUp	Scroll up the document or page
fn + PgDn	Scroll down the document or page
fn + Home	Move to the beginning of the document
fn + End	Move to the end of the document
Copilot	<p>Launch Copilot in Windows</p> <p>NOTE: If Copilot in Windows is not available on your computer, the Copilot key launches Recall. If both Recall and Copilot in Windows are not available on your computer, the Copilot key launches Windows Search. For more information about Copilot in Windows and Recall, search in the Knowledge Base Resource at the Dell Support Site.</p>
fn + left arrow	Home (move to the beginning of the document)
fn + right arrow	End (move to the end of the document)

Camera

The following table lists the camera specifications of your Dell 16 DC16250.

Table 15. Camera specifications

Description	Values
Number of cameras	One
Camera type	HD RGB camera
Camera location	Front camera
Camera sensor type	CMOS sensor technology
Camera resolution:	
Still image	0.92 megapixel
Video	1280 x 720 (HD) at 30 fps
Diagonal viewing angle	74.90 degrees

Touchpad

The following table lists the touchpad specifications of your Dell 16 DC16250.

Table 16. Touchpad specifications

Description		Values
Touchpad resolution:		
	Horizontal	305 dpi
	Vertical	305 dpi
Touchpad dimensions:		
	Horizontal	115 mm (4.52 in.)
	Vertical	80 mm (3.15 in.)
Touchpad gestures		For more information about the touchpad gestures available on Windows, search Microsoft Support Site .

Power adapter

The following table lists the power adapter specifications of your Dell 16 DC16250.

Table 17. Power-adapter specifications

Description		Values
Type		65 W DC-in adapter, 4.50 mm barrel, E4
Power-adapter dimensions:		
	Height	108 mm (4.25 in.)
	Width	47 mm (1.85 in.)
	Depth	28 mm (1.10 in.)
Input voltage		100 VAC–240 VAC
Input frequency		50 Hz–60 Hz
Input current (maximum)		1.70 A
Output current (continuous)		3.34 A
Rated output voltage		19.50 VDC
Temperature range:		
	Operating	0°C to 40°C (32°F to 104°F)
	Storage	-40°C to 70°C (-40°F to 158°F)

 **CAUTION:** Operating and storage temperature ranges may differ among components, so operating or storing the device outside these ranges may impact the performance of specific components.

Power adapter requirements of Dell 16 DC16250

NOTE: If you did not purchase the Dell-branded power adapter that is recommended for your computer, ensure that the power adapter you use meets the following requirements.

The following table lists the power adapter requirements for your Dell 16 DC16250.

Table 18. Power adapter requirements

Description	Value
Power that is required from a power adapter to achieve optimal performance	60 W
Power that charges the computer at a slower speed NOTE: A warning message may appear informing you about the use of a lower-powered adapter and slower charging speed.	Less than 60 W
Minimum power that is required from a power adapter to operate the computer and charge the battery NOTE: A warning message appears informing you about the use of a lower-powered adapter and slower charging speed.	27 W
USB Power Delivery (PD) fast charging	Supported
ExpressCharge mode	Supported NOTE: Ensure that the computer with a 42 Wh battery is connected to a 65 W power adapter for this feature to be supported.

Battery

The following table lists the battery specifications of your Dell 16 DC16250.

Table 19. Battery specifications

Description	Option one	Option two
Battery type	3-cell, 41 Wh, Lithium Ion Polymer, ExpressCharge Boost	4-cell, 54 Wh, Lithium Ion Polymer, ExpressCharge Capable
Battery voltage	11.25 VDC	15 VDC
Battery weight (maximum)	0.18 kg (0.40 lb)	0.24 kg (0.53 lb)
Battery dimensions:		
	Height	5.75 mm (0.23 in.)
	Width	206.40 mm (8.13 in.)
	Depth	82 mm (3.22 in.)
Temperature range:		
	Operating	<ul style="list-style-type: none"> Charge: 0°C to 45°C (32°F to 113°F) Discharge: 0°C to 70°C (32°F to 158°F)
	Storage	-20°C to 60°C (-4°F to 140°F)

Table 19. Battery specifications (continued)

Description	Option one	Option two
Battery operating time	Varies depending on operating conditions and can significantly reduce under certain power-intensive conditions.	Varies depending on operating conditions and can significantly reduce under certain power-intensive conditions.
Battery charging time (approximate) ⓘ NOTE: You can control the charging time, duration, start and end time, and so on, using the settings on the MyDell application (Power option). For more information about MyDell application, search in the Knowledge Base Resource at Dell Support Site .	<ul style="list-style-type: none"> • 3 hr (Standard charge) • 2 hr (Express charge) 	<ul style="list-style-type: none"> • 3 hr (Standard charge) • 2 hr (Express charge)
Coin-cell battery	N/A	N/A
⚠ CAUTION: Operating and storage temperature ranges may differ among components, so operating or storing the device outside these ranges may impact the performance of specific components. ⚠ CAUTION: Dell Technologies recommends that you charge the battery regularly for optimal power consumption.		

Power requirements (for computers shipped with 3-cell, 41 Wh battery)

ⓘ **NOTE:** The information in this section is applicable to the European Union (EU) countries.

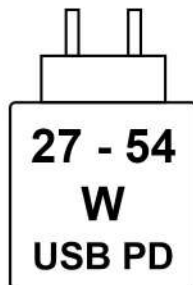

Figure 9. Pictogram for 41 Wh battery

The power that is delivered by the charger must be between a minimum of 27 Watts that is required by the radio equipment, and a maximum of 54 Watts in order to achieve the maximum charging speed.

This computer supports USB Power Delivery (PD) fast charging.

Power requirements (for computers shipped with 4-cell, 54 Wh battery)

ⓘ **NOTE:** The information in this section is applicable to the European Union (EU) countries.

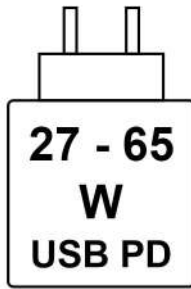

Figure 10. Pictogram for 54 Wh battery

The power that is delivered by the charger must be between a minimum of 27 Watts that is required by the radio equipment, and a maximum of 65 Watts in order to achieve the maximum charging speed.

This computer supports USB Power Delivery (PD) fast charging.

Display

The following table lists the display specifications of your Dell 16 DC16250.

Table 20. Display specifications

Description	Option one	Option two
Display type	16" Full High Definition Plus (FHD+) with ComfortView	16" Full High Definition Plus (FHD+) with ComfortView
Touch options	No	Yes
Display-panel technology	Wide Viewing Angle (WVA)	Wide Viewing Angle (WVA)
Display-panel dimensions (active area):		
Height	344.68 mm (13.57 in.)	344.68 mm (13.57 in.)
Width	215.42 mm (8.48 in.)	215.42 mm (8.48 in.)
Diagonal	406.46 mm (16 in.)	406.46 mm (16 in.)
Display-panel native resolution	1920 x 1200	1920 x 1200
Luminance (typical)	300 nits	300 nits
Megapixels	2.30	2.30
Color gamut	45% NTSC (typical)	45% NTSC (typical)
Pixels Per Inch (PPI)	141	141
Contrast ratio	<ul style="list-style-type: none"> 800:1 (minimum) 1000:1 (typical) 	<ul style="list-style-type: none"> 800:1 (minimum) 1000:1 (typical)
Response time (maximum)	35 ms	35 ms
Refresh rate	60 Hz	60 Hz
Horizontal view angle	<ul style="list-style-type: none"> +/- 80 degrees (minimum) +/- 85 degrees (typical) 	<ul style="list-style-type: none"> +/- 85 degrees (typical) +/- 80 degrees (minimum)

Table 20. Display specifications (continued)

Description	Option one	Option two
Vertical view angle	<ul style="list-style-type: none"> +/- 80 degrees (minimum) +/- 85 degrees (typical) 	<ul style="list-style-type: none"> +/- 85 degrees (typical) +/- 80 degrees (minimum)
Pixel pitch	0.18 mm	0.18 mm
Power consumption (maximum)	4.45 W	5.60 W
Anti-glare vs glossy finish	Anti-Glare	Anti-Glare

Fingerprint reader (optional)

The following table lists the specifications of the optional fingerprint-reader of your Dell 16 DC16250.

Table 21. Fingerprint reader specifications

Description	Values
Sensor technology	Capacitive
Sensor resolution	500 dpi
Sensor pixel size	108 mm x 88 mm

Sensors

The following table lists the sensors of your Dell 16 DC16250.

Table 22. Sensor

Sensor support
Accelerometer

GPU—Integrated

The following table lists the specifications of the integrated Graphics Processing Unit (GPU) supported by your Dell 16 DC16250.

Table 23. GPU—Integrated

Controller	Memory size	Processor
Intel Graphics	Shared system memory	Intel Core 5 and 7 processors

External display support

The following table lists the external display support for your Dell 16 DC16250.

Table 24. External display support

Graphics card	Supported external displays with laptop display enabled	Supported external displays with laptop display disabled
Intel Graphics	2	2

GPU—Discrete

The following table lists the specifications of the discrete Graphics Processing Unit (GPU) supported by your Dell 16 DC16250.

Table 25. GPU—Discrete

Controller	Memory size	Memory type
NVIDIA GeForce MX570A	2 GB	GDDR6

External display support

The following table lists the external display support for your Dell 16 DC16250.

Table 26. External display support

Graphics card	Supported external displays with laptop display enabled	Supported external displays with laptop display disabled
NVIDIA GeForce MX570A	2	2
 NOTE: For more information about external display support, see the <i>External Display Connection Guide</i> on Dell Support Site .		

Hardware security

The following table lists the hardware security of your Dell 16 DC16250.

Table 27. Hardware security

Hardware security
Wedge-shaped lock slot
Trusted Platform Module (TPM) 2.0
Windows Hello - Fingerprint Reader (optional)

Operating and storage environment

This table lists the operating and storage specifications of your Dell 16 DC16250.

Airborne contaminant level: G1 as defined by ISA-S71.04-1985

Table 28. Computer environment

Description	Operating	Storage
Temperature range	0°C–35°C (32°F–95°F)	-40°C to 70°C (-40°F to 158°F)
Relative humidity (maximum)	10% to 90% (non-condensing)	5% to 95% (non-condensing)
Vibration (maximum)*	0.66 GRMS	1.30 GRMS
Shock (maximum)	110 G†	160 G†
Altitude range	-15.20 m to 3048 m (-49.87 ft to 10,000 ft)	-15.20 m to 10,668 m (-49.87 ft to 35,000 ft)

Table 28. Computer environment (continued)

Description	Operating	Storage
 CAUTION: Operating and storage temperature ranges may differ among components, so operating or storing the device outside these ranges may impact the performance of specific components.		

* Measured using a random vibration spectrum that simulates the user environment.

† Measured using a 2 ms half-sine pulse.

Dell support policy

For information about Dell support policy, search [Dell Support Site](#).

ComfortView

 **WARNING: Prolonged exposure to blue light from the display may lead to long-term effects such as eye strain, eye fatigue, or damage to the eyes.**

Blue light is a color in the light spectrum which has a short wavelength and high energy. Chronic exposure to blue light, particularly from digital sources, may disrupt sleep patterns and cause long-term effects such as eye strain, eye fatigue, or damage to the eyes.

Dell ComfortView software technology reduces harmful blue light emissions to make extended screen time easy on your eyes.

ComfortView mode can be enabled and configured using the Dell CinemaColor application.

ComfortView mode complies with TÜV Rheinland's requirement for low blue light displays.

To reduce the risk of eye strain, it is also recommended that you:

- Position the display at a comfortable viewing distance between 20 and 28 inches (50 cm and 70 cm) from your eyes.
- Blink frequently to moisten your eyes, wet your eyes with water, or apply suitable eye drops.
- Take an extended break for 20 minutes every two hours.
- Look away from your display, and gaze at a distant object at 20 ft (609.60 cm) away for at least 20 seconds during each break.

Dell Optimizer

Dell Optimizer is an AI-based software application that allows you to customize your computer settings for power and battery, and more.

For Dell 16 DC16250 with Dell Optimizer, you can:









- Extend the battery life of your computer with Intelligent Battery Extender and Dynamic Charge.
- Tune the performance, power consumption, cooling, and fan noise with selectable thermal modes.
- Access and secure your computer depending on your physical presence.
- Download and redeem the apps that are purchased with your computer.

For more information about configuring and using these features, search for *Dell Optimizer* at the [Dell Support Site](#).

Working inside your computer

Safety instructions

Use the following safety guidelines to protect your computer from potential damage and to ensure your personal safety. Unless otherwise noted, each procedure in this document assumes that you have read the safety information that shipped with your computer.



-  **WARNING:** Before working inside your computer, read the safety information that is shipped with your computer. For more safety best practices, see [Dell Regulatory Compliance Home Page](#).
-  **WARNING:** Disconnect your computer from all power sources before opening the computer cover or panels. After you finish working inside the computer, replace all covers, panels, and screws before connecting your computer to an electrical outlet.
-  **WARNING:** For laptops, discharge the battery completely before removing it. Disconnect the AC power adapter from the computer and operate the computer solely on battery power—the battery is fully discharged when the computer no longer turns on when the power button is pressed.
-  **CAUTION:** To avoid damaging the computer, ensure that the work surface is flat, dry, and clean.
-  **CAUTION:** You should only perform troubleshooting and repairs as authorized or directed by the Dell technical support team. Damage due to servicing that is not authorized by Dell is not covered by your warranty.
-  **CAUTION:** Before touching anything inside your computer, ground yourself by touching an unpainted metal surface, such as the metal at the back of the computer. While you work, periodically touch an unpainted metal surface to dissipate static electricity which could harm internal components.
-  **CAUTION:** To avoid damaging the components and cards, handle them by their edges, and avoid touching the pins and the contacts.
-  **CAUTION:** When you disconnect a cable, pull it by its connector or its pull tab, not the cable itself. Some cables have connectors with locking tabs or thumbscrews that you must disengage before disconnecting the cable. When disconnecting cables, keep them evenly aligned to avoid bending the connector pins. When connecting cables, ensure that the connector on the cable is correctly oriented and aligned with the port.
-  **CAUTION:** Press and eject any installed card from the media-card reader.

Before working inside your computer

About this task

 **NOTE:** The images in this document may differ from your computer depending on the configuration you ordered.

Steps

1. Save and close all open files and exit all open applications.
2. Shut down your computer. For Windows operating system, click **Start** >  **Power** > **Shut down**.
 **NOTE:** If you are using a different operating system, see the documentation of your operating system for instructions.
3. Turn off all the attached peripherals.
4. Disconnect your computer from the electrical outlet.

5. Disconnect all attached network devices and peripherals, such as keyboard, mouse, and monitor from your computer.
6. Remove any media card and optical drive from your computer, if applicable.
7. To clean the air vents, use a soft brush and move vertically.

 **NOTE:** Do not remove the base cover or use any blower to clean the vents.

8. Enter the Service Mode.

Service Mode

Service Mode is used to cut off power without disconnecting the battery cable from the system board before conducting repairs in the computer.

 **CAUTION:** If you are unable to turn on the computer to put it into Service Mode, disconnect the battery cable. To disconnect the battery cable, follow the steps in [Removing the battery](#).

 **NOTE:** Ensure that your computer is shut down and the power adapter is disconnected.

- a. Press and hold the B key and the power button for 3 seconds, or until the Dell logo appears on the screen.
- b. If the **Owner Tag** is set, it is displayed on the screen. Press any key to continue.

 **NOTE:** If the **Owner Tag** information is not already set, the computer automatically skips this step and proceeds to enter Service Mode.

- c. If the power adapter is still connected, a message appears on the screen prompting you to disconnect it. Disconnect the power adapter, then press any key to continue.
- d. When the **System Ready For Service** message appears on the screen, press any key to proceed. The computer emits three short beeps and shuts down immediately. The computer shuts down and enters the Service Mode.

Safety precautions

This section details the primary steps to be followed before disassembling any device or component.

Observe the following safety precautions before any installation or break-fix procedures involving disassembly or reassembly:

- Turn off the computer and all attached peripherals.
- Disconnect the computer from AC power.
- Disconnect all network cables and peripherals from the computer.
- Use an ESD field service kit when working inside your computer to avoid electrostatic discharge (ESD) damage.
- Place the removed component on an anti-static mat after removing it from the computer.
- Press and hold the power button for 15 seconds to discharge the residual power in the system board.

Bonding

Bonding is a method for connecting two or more grounding conductors to the same electrical potential. This is done by using a field service electrostatic discharge (ESD) kit. When connecting a bonding wire, ensure that it is connected to bare metal and never to a painted or nonmetal surface. Ensure that the wrist strap is secure and in full contact with your skin. Remove all jewelry, watches, bracelets, or rings before grounding yourself and the equipment.

Electrostatic discharge—ESD protection

ESD is a major concern when you handle electronic components, especially sensitive components such as expansion cards, processors, memory modules, and system boards. A slight charge can damage circuits in ways that may not be obvious, such as intermittent problems or a shortened product life span. As the industry pushes for lower power requirements and increased density, ESD protection is an increasing concern.

Two recognized types of ESD damage are catastrophic and intermittent failures.

- **Catastrophic** – Catastrophic failures represent approximately 20 percent of ESD-related failures. The damage causes an immediate and complete loss of device functionality. An example of catastrophic failure is a memory module that has received a static shock and immediately generates a "No POST/No Video" symptom with a beep code that is emitted for missing or nonfunctional memory.

- **Intermittent** – Intermittent failures represent approximately 80 percent of ESD-related failures. The high rate of intermittent failures means that most of the time when damage occurs, it is not immediately recognizable. The memory module receives a static shock, but the tracing is merely weakened and does not immediately produce outward symptoms that are related to the damage. The weakened trace may take weeks or months to melt, and in the meantime may cause degradation of memory integrity, intermittent memory errors, and so on.

Intermittent failures that are also called latent or "walking wounded" are difficult to detect and troubleshoot.

Perform the following steps to prevent ESD damage:

- Use a wired ESD wrist strap that is properly grounded. Wireless anti-static straps do not provide adequate protection. Touching the chassis before handling parts does not ensure adequate ESD protection on parts with increased sensitivity to ESD damage.
- Handle all static-sensitive components in a static-safe area. If possible, use anti-static floor pads and workbench pads.
- When unpacking a static-sensitive component from its shipping carton, do not remove the component from the anti-static packing material until you are ready to install the component. Before unwrapping the anti-static packaging, use the anti-static wrist strap to discharge the static electricity from your body.

i **NOTE:** You can protect against ESD and discharge static electricity from your body by touching a metal-grounded object before you interact with anything electronic, for example, an unpainted metal surface on your computer's I/O panel. When connecting a peripheral (including handheld digital assistants) to your computer, you should always ground both yourself and the peripheral before connecting it to the computer. In addition, as you work inside the computer, periodically touch a metal-grounded object to remove any static charge that your body may have accumulated.

For more information about the wrist strap and ESD wrist strap tester, see [Components of an ESD Field Service Kit](#).

- Before transporting a static-sensitive component, place it in an anti-static container or packaging.

ESD Field Service kit

The unmonitored field service kit is the most commonly used service kit. Each Field Service kit includes three main components: anti-static mat, wrist strap, and bonding wire.

⚠ CAUTION: It is critical to keep ESD-sensitive devices away from internal parts that are insulated and often highly charged, such as plastic heat sink casings.

Working environment

Before the ESD Field Service kit is deployed, conduct an evaluation of the site to ensure proper setup and readiness. For example, deploying the kit for a server environment is different than for a desktop or laptop environment. Servers are typically installed in a rack within a data center; desktops or laptops are typically placed on office desks or cubicles. Always look for a large open flat work area that is free of clutter and large enough to deploy the ESD kit with additional space to accommodate the type of computer that is being repaired. The workspace should also be free of insulators that can cause an ESD event. On the work area, insulators such as styrofoam and other plastics should always be moved at least 12 inches or 30 centimeters away from sensitive parts before physically handling any hardware components.

ESD packaging

All ESD-sensitive devices must be shipped and received in static-safe packaging. Metal, static-shielded bags are preferred. However, you should always return the damaged component using the same ESD bag and packaging that the new part arrived in. The ESD bag should be folded over and taped shut and all the same foam packing material should be used in the original box that the new part arrived in. ESD-sensitive devices should be removed from packaging only at an ESD-protected work surface, and parts should never be placed on top of the ESD bag because only the inside of the bag is shielded. Always place parts in your hand, on the anti-static mat, in the computer, or inside an ESD bag.

Components of an ESD Field Service kit

The components of an ESD Field Service kit are:

- **Anti-Static Mat** – The anti-static mat is dissipative and parts can be placed on it during service procedures. When using an anti-static mat, your wrist strap should be snug and the bonding wire should be connected to the anti-static mat and to any bare metal on the computer being worked on. Once deployed properly, service parts can be removed from the ESD bag and

placed directly on the anti-static mat. ESD-sensitive items are safe in your hand, on the anti-static mat, in the computer, or inside an ESD bag.

- **Wrist Strap and Bonding Wire** – If an anti-static mat is not being used, the wrist strap and bonding wire should be connected directly between your wrist and an exposed metal part of the hardware. If you are using an anti-static mat, connect the wrist strap and bonding wire to the anti-static mat to ensure protection for any hardware placed on the mat. The physical connection of the wrist strap and bonding wire between your skin, the anti-static mat, and the hardware is known as bonding. Use only Field Service kits with a wrist strap, anti-static mat, and bonding wire. Never use wireless wrist straps. Always be cautious that the internal wires of a wrist strap are prone to damage from normal wear and tear, and must be checked regularly with a wrist strap tester in order to avoid accidental ESD hardware damage. It is recommended to test the wrist strap and bonding wire at least once per week.
- **ESD Wrist Strap Tester** – The wires inside an ESD strap are prone to damage over time. When using an unmonitored ESD kit, it is recommended to test the wrist strap regularly—ideally before each service session, and at a minimum, once per week. The most reliable method for testing is with a wrist strap tester. To perform the test, connect the bonding wire of the wrist strap to the tester while wearing the strap. Press the test button to initiate the check. A green LED indicates a successful test, while a red LED and audible alarm signal a failure.

NOTE: It is recommended to always use the traditional wired ESD grounding wrist strap and protective anti-static mat when servicing Dell products. In addition, it is critical to keep sensitive parts separate from all insulator parts while servicing the computer.

Transporting sensitive components

When transporting ESD sensitive components such as replacement parts or parts to be returned to Dell, it is critical to place these parts in anti-static bags for safe transport.

After working inside your computer

About this task

CAUTION: Leaving stray or loose screws inside your computer may severely damage your computer.

Steps

1. Replace all screws and ensure that no stray screws remain inside your computer.
2. Connect any external devices, peripherals, or cables you removed before working on your computer.
3. Replace any media cards, disks, or any other parts that you removed before working on your computer.
4. Connect your computer to their electrical outlets.

NOTE: To exit service mode, ensure to connect the AC adapter to the power-adapter port on your computer.

5. Press the power button to turn on the computer.

Information on repairability for Québec - From Dell Canada Inc. - to Quebec consumers

Dell does not guarantee the availability of replacement parts, repair services, or information necessary for maintenance or repair.

BitLocker

When updating the BIOS on a computer with BitLocker enabled, consider the following precautions.

CAUTION: If BitLocker is not suspended before updating the BIOS, the BitLocker key will not be recognized the next time that you reboot the computer. You are prompted to enter the recovery key to progress, and the computer displays a prompt for the recovery key on each reboot. If the recovery key is not known, this can

result in data loss or an operating system reinstall. For more information, see Knowledge Article: [updating the BIOS on Dell computers with BitLocker enabled](#).

The installation of the following components triggers BitLocker:

- Hard disk drive or solid state drive
- System board

Recommended tools

The procedures in this document may require the following tools:

- Phillips screwdriver #0
- Plastic scribe

Screw list

- i NOTE:** When removing screws from a component, it is recommended to note the screw type and the quantity of screws, and then place them in a screw storage box. This is to ensure that the correct number of screws and correct screw type is restored when the component is replaced.
- i NOTE:** Some computers have magnetic surfaces. Ensure that the screws are not left attached to such surfaces when replacing a component.
- i NOTE:** Screw color may vary depending on the configuration ordered.

Table 29. Screw list





















Component	Screw type	Quantity	Screw image
Base cover	Captive screw	2	
	M2x5	6	
Battery	M2x3.5	<ul style="list-style-type: none"> • 3 screws for 3-cell battery • 5 screws for 4-cell battery 	
Solid state drive bracket	M2x3.5	3	
Solid state drive	M1.6x1.8	1	
Wireless card	M2x3.5	1	
Speakers	M2x2.3	4	
Fan	M2x5.5	2	
Heat sink - for computers shipped with integrated graphics card	Captive screws	4	

Table 29. Screw list (continued)

Component	Screw type	Quantity	Screw image
Heat sink - for computers shipped with discrete graphics card	M2x3.5	3	
	Captive screws	4	
Touchpad	M1.6x1.8	7	
Display hinges	M2.5x5	5	
I/O board	M2x3.5	3	
Display panel	M2x2.5	2	
	M2.5x3	8	
Power button	M1.6x1.8	1	
Power button with fingerprint reader	M1.6x1.8	1	
System board	M2x3.5	4	
	M1.6x1.8	1	

Major components of Dell 16 DC16250

The following image shows the major components of Dell 16 DC16250.

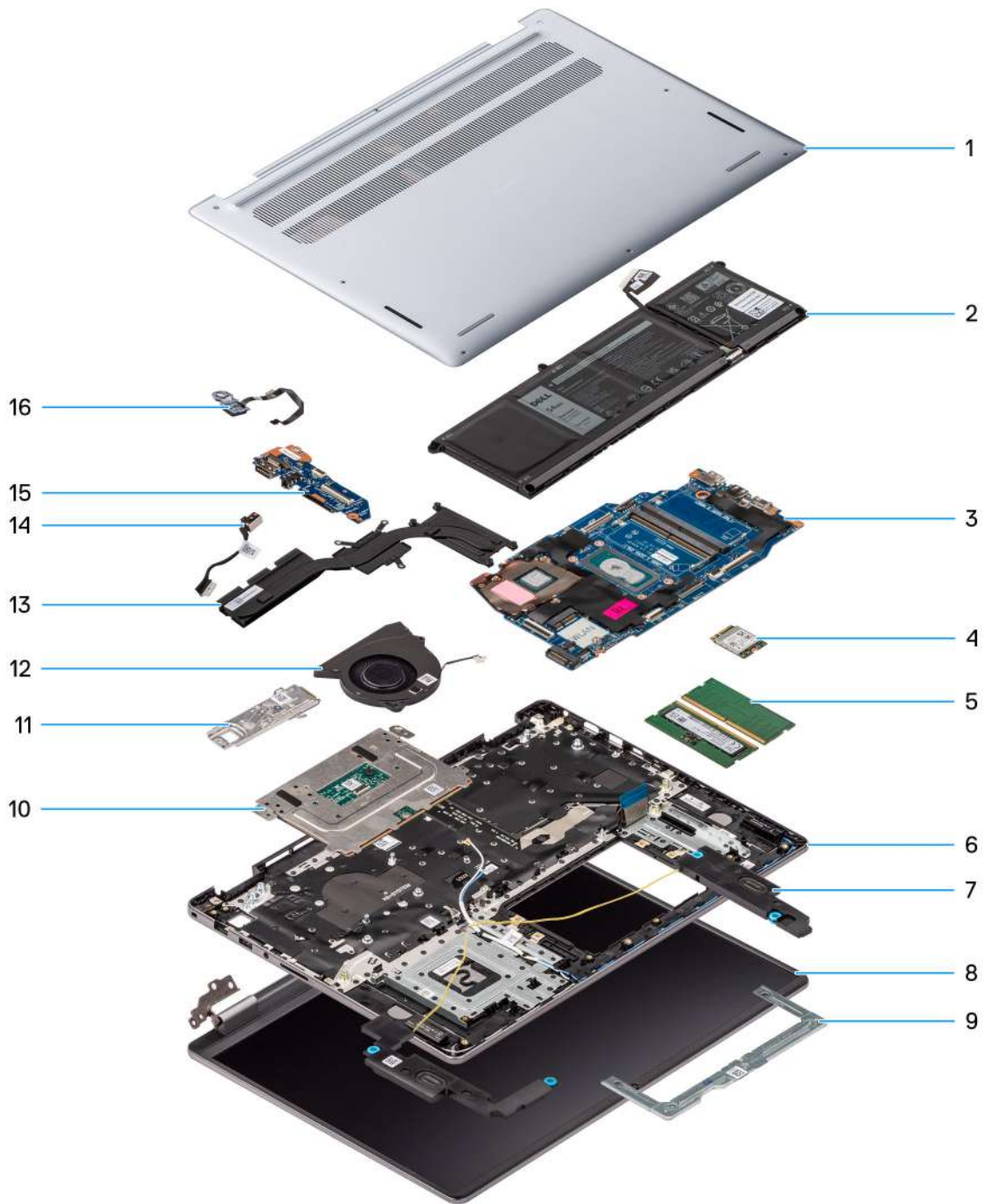



Figure 11. Major components of Dell 16 DC16250

1. Base cover
2. Battery
3. System board
4. Wireless card
5. Memory modules
6. Palm-rest and keyboard assembly
7. Speakers
8. Display assembly
9. Touchpad bracket
10. Touchpad
11. Solid state drive with bracket

12. Fan
13. Heat sink
14. Power-adaptor port
15. I/O board
16. Power button with optional fingerprint reader

 **NOTE:** Dell provides a list of components and their part numbers for the original computer configuration purchased. These parts are available according to warranty coverage purchased by the customer. Contact your Dell sales representative for purchase options.

Removing and installing Customer Replaceable Units (CRUs)

The replaceable components in this chapter are Customer Replaceable Units (CRUs).

 **CAUTION:** Customers can replace only the Customer Replaceable Units (CRUs) following the safety precautions and replacement procedures.

 **NOTE:** The images in this document may differ from your computer depending on the configuration you ordered.

Base cover

Removing the base cover

Prerequisites

1. Follow the procedure in [Before working inside your computer](#).

 **CAUTION:** Ensure that your computer is in Service Mode. If the computer does not turn on, does not enter Service Mode, or does not support Service Mode, proceed to disconnect the battery cable.

About this task

The following images indicate the location of the base cover and provide a visual representation of the removal procedure.

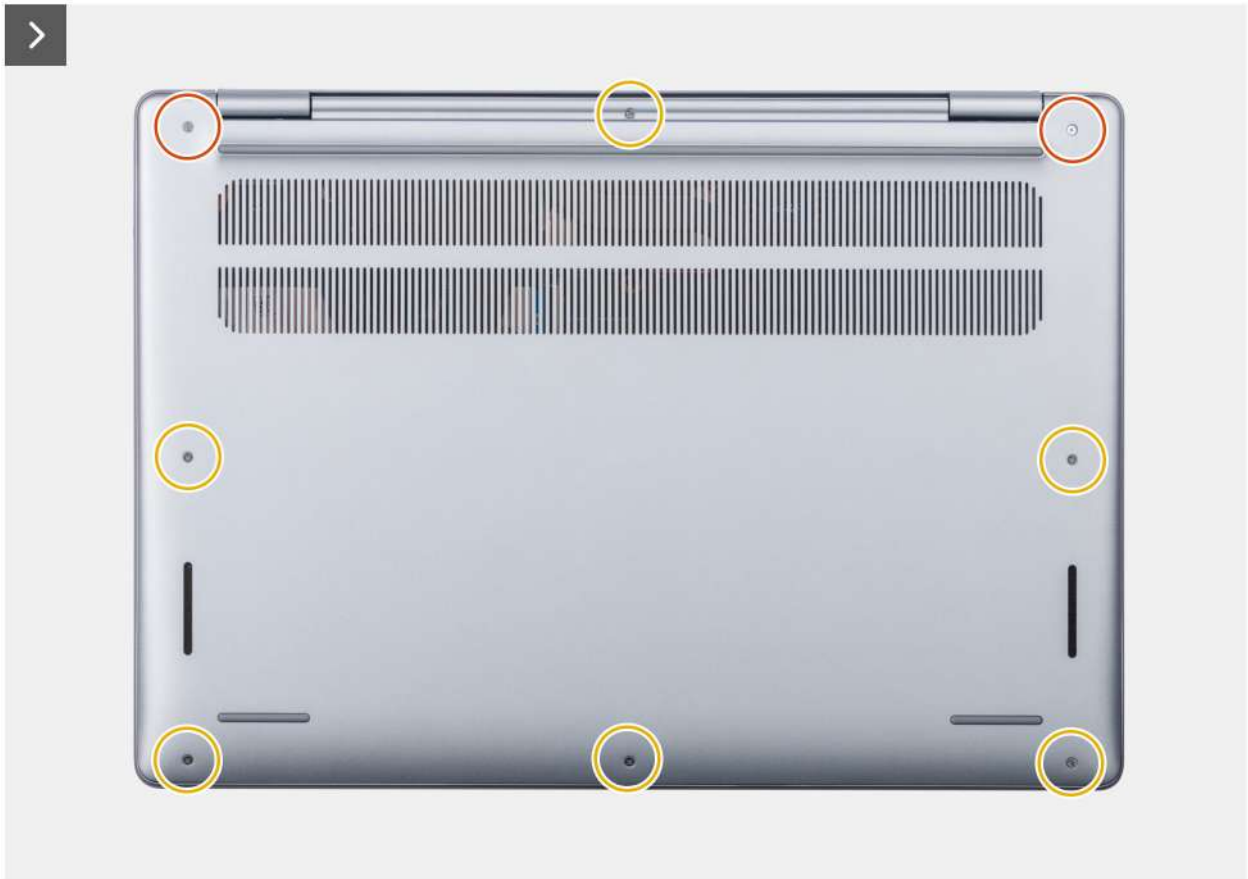

Figure 12. Removing the base cover

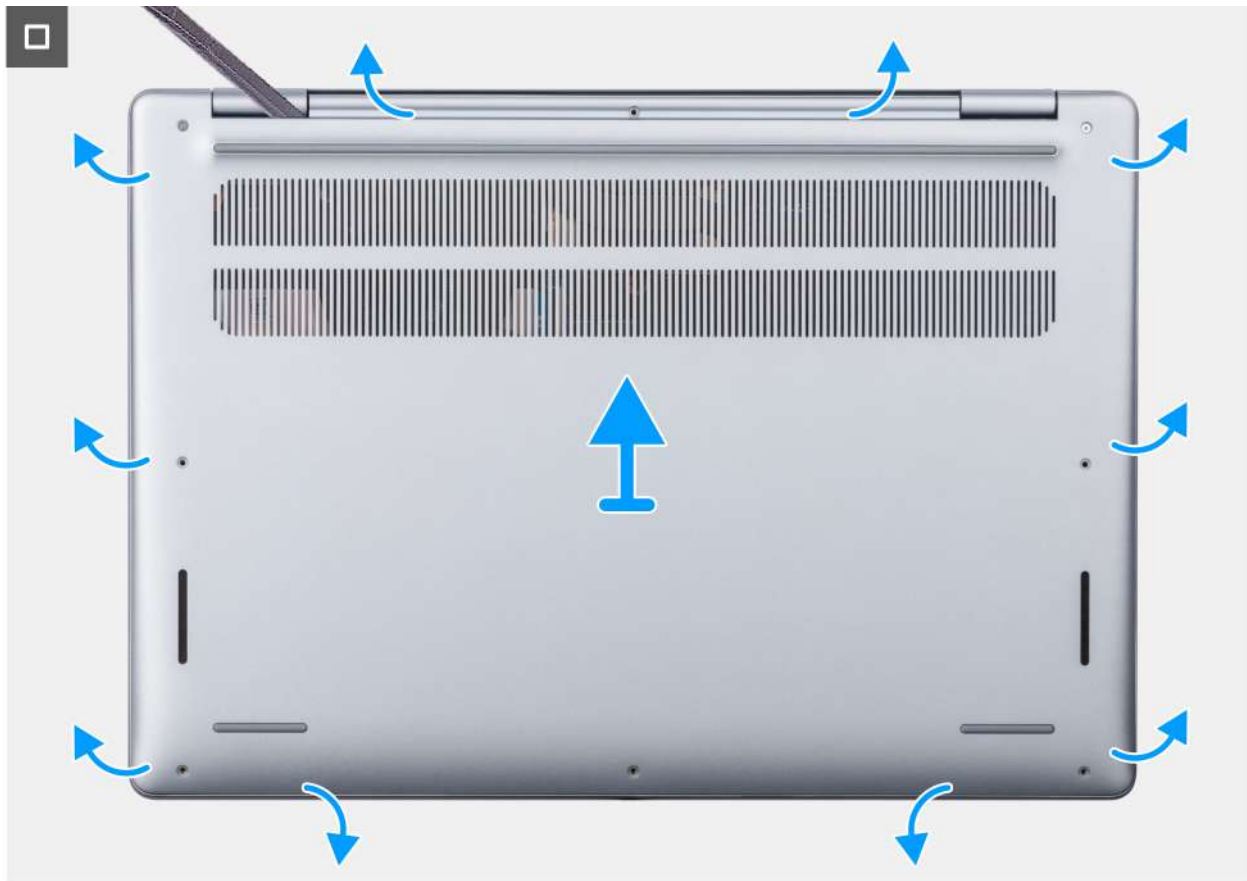

Figure 13. Removing the base cover

Steps

1. Remove the six screws (M2x5) and loosen the two captive screws that secure the base cover to the palm-rest and keyboard assembly.
NOTE: Upon loosening the captive screws, the base cover opens up creating a gap between the base cover and the palm-rest assembly at the hinges.
2. Using a plastic scribe, pry open the base cover starting from the recesses, which are located in the U-shaped indents at the top edge of the base cover, near the hinges.
3. Pry open the top side of the base cover and continue working on the left, right, and bottom sides to release to open the base cover.
4. Lift and remove the base cover off the palm-rest and keyboard assembly.

Installing the base cover

Prerequisites

If you are replacing a component, remove the existing component before performing the installation procedure.

About this task

The following images indicate the location of the base cover and provide a visual representation of the installation procedure.

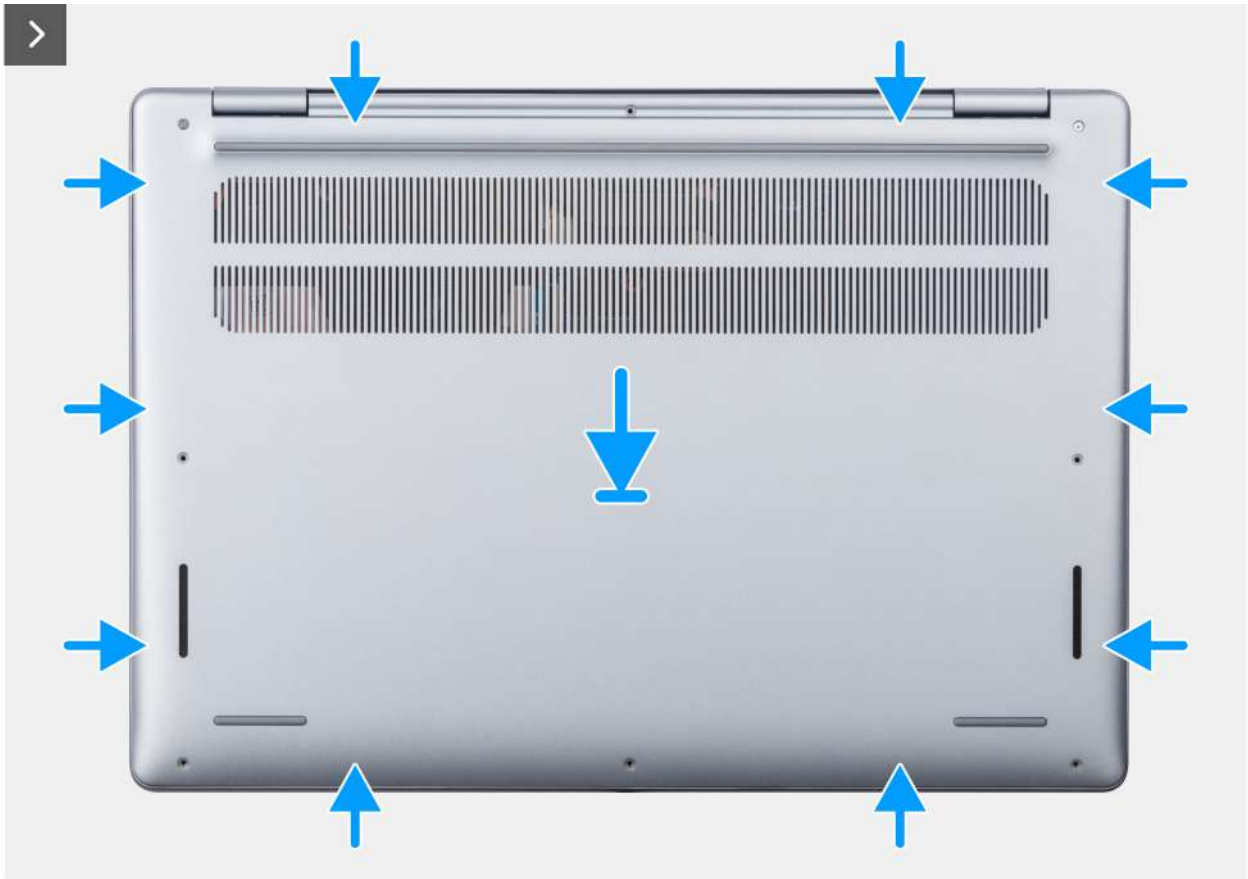

Figure 14. Installing the base cover

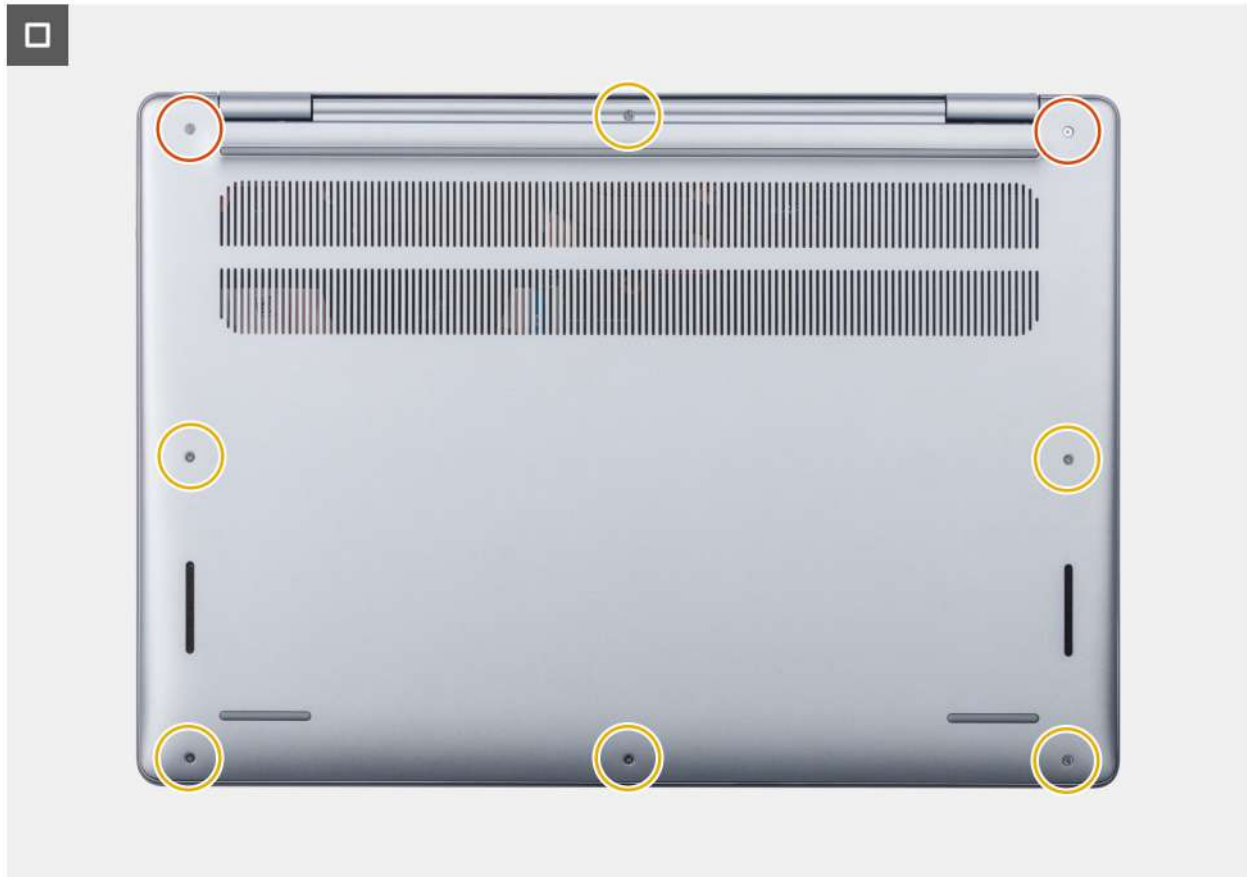

Figure 15. Installing the base cover

Steps

1. Place the base cover on the palm-rest and keyboard assembly.
2. Align the screw holes on the base cover with the screw holes on the palm-rest and keyboard assembly, and then snap the base cover into place.
3. Tighten the two captive screws and replace the six screws (M2x5) to secure the base cover to the palm-rest and keyboard assembly.

Next steps

1. Follow the procedure in [After working inside your computer](#).

Battery

Rechargeable Li-ion battery precautions

WARNING:

- Exercise caution when handling rechargeable Li-ion batteries.

- Discharge the battery completely before removing it. Disconnect the AC power adapter from the computer and operate the computer solely on battery power—the battery is fully discharged when the computer no longer turns on when the power button is pressed.
- Do not crush, drop, mutilate, or penetrate the battery with foreign objects.
- Do not expose the battery to high temperatures, or disassemble battery packs and cells.
- Do not apply pressure to the surface of the battery.
- Do not bend the battery.
- Do not use tools of any kind to pry on or against the battery.
- To prevent accidental puncture or damage to the battery and other components, ensure that no screws are lost or misplaced during the servicing of the computer.
- Always purchase genuine batteries from [Dell Site](#) or authorized Dell partners and resellers.
- Swollen batteries should not be used and should be replaced and disposed properly. For guidelines on how to handle and replace swollen rechargeable Li-ion batteries, see [Handling swollen rechargeable Li-ion batteries](#).

Removing the 3-cell battery

Prerequisites

1. Follow the procedure in [Before working inside your computer](#).
2. Remove the [base cover](#).

About this task

The following image indicates the location of the 3-cell battery and provides a visual representation of the removal procedure.

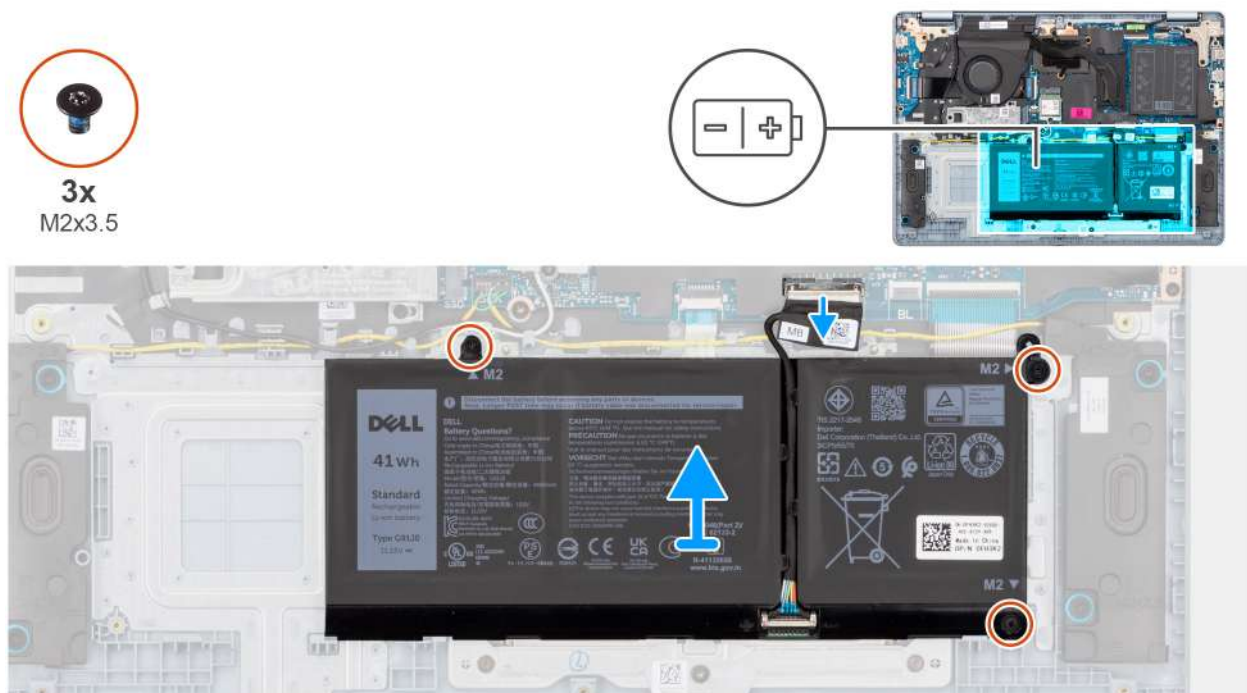

Figure 16. Removing the 3-cell battery

Steps

1. Open the latch and disconnect the battery cable from the connector (BATT) on the system board.
2. Remove the three screws (M2x3.5) that secure the battery to the palm-rest and keyboard assembly.
3. Lift the battery, along with the battery cable, off the palm-rest and keyboard assembly.

NOTE: Battery and battery cable are separate serviceable parts. If battery replacement is required, reuse the same battery cable. To disconnect the battery cable, see [Disconnecting the battery cable](#).

Installing the 3-cell battery

Prerequisites

If you are replacing a component, remove the existing component before performing the installation procedure.

About this task

The following image indicates the location of the 3-cell battery and provides a visual representation of the installation procedure.

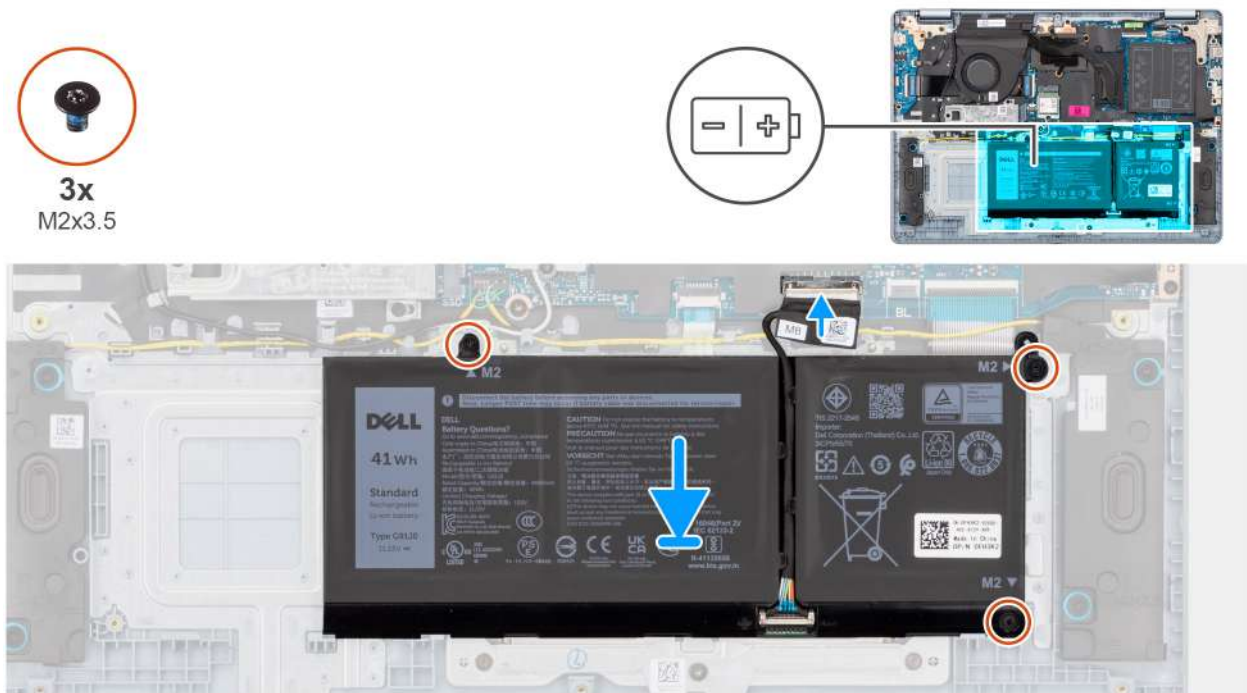

Figure 17. Installing the 3-cell battery

NOTE: Battery and battery cable are separate serviceable parts. If battery replacement is required, reuse the same battery cable. To connect the battery cable, see [Connecting the battery cable](#).

Steps

1. Place the battery, along with the battery cable, in the slot on the palm-rest and keyboard assembly.

NOTE: When placing the battery, insert the tabs on the battery into the hooks on the palm-rest and keyboard assembly.



Figure 18. Installing the battery - Insert the tabs into hooks

2. Align the screw holes on the battery with the screw holes on the palm-rest and keyboard assembly.
3. Replace the three screws (M2x3.5) to secure the battery to the palm-rest and keyboard assembly.
4. Connect the battery cable to the connector (BATT) on the system board.

Next steps

1. Install the [base cover](#).
2. Follow the procedure in [After working inside your computer](#).

Removing the 4-cell battery

Prerequisites

1. Follow the procedure in [Before working inside your computer](#).
2. Remove the [base cover](#).

About this task

The following image indicates the location of the battery and provides a visual representation of the removal procedure.

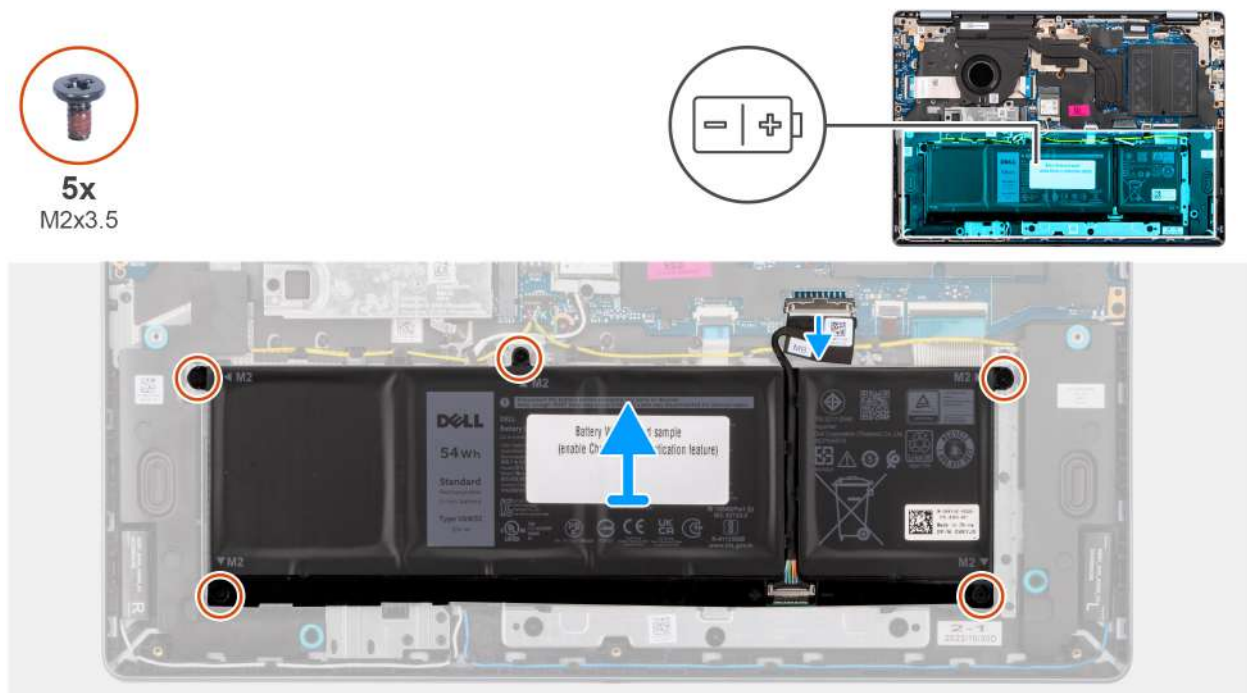

Figure 19. Removing the 4-cell battery

Steps

1. Open the latch and disconnect the battery cable from the connector (BATT) on the system board.
2. Remove the five screws (M2x3.5) that secure the battery to the palm-rest and keyboard assembly.
3. Lift the battery, along with the battery cable, off the palm-rest and keyboard assembly.

NOTE: Battery and battery cable are separate serviceable parts. If battery replacement is required, reuse the same battery cable. To disconnect the battery cable, see [Disconnecting the battery cable](#).

Installing the 4-cell battery

Prerequisites

If you are replacing a component, remove the existing component before performing the installation procedure.

About this task

The following image indicates the location of the battery and provides a visual representation of the installation procedure.

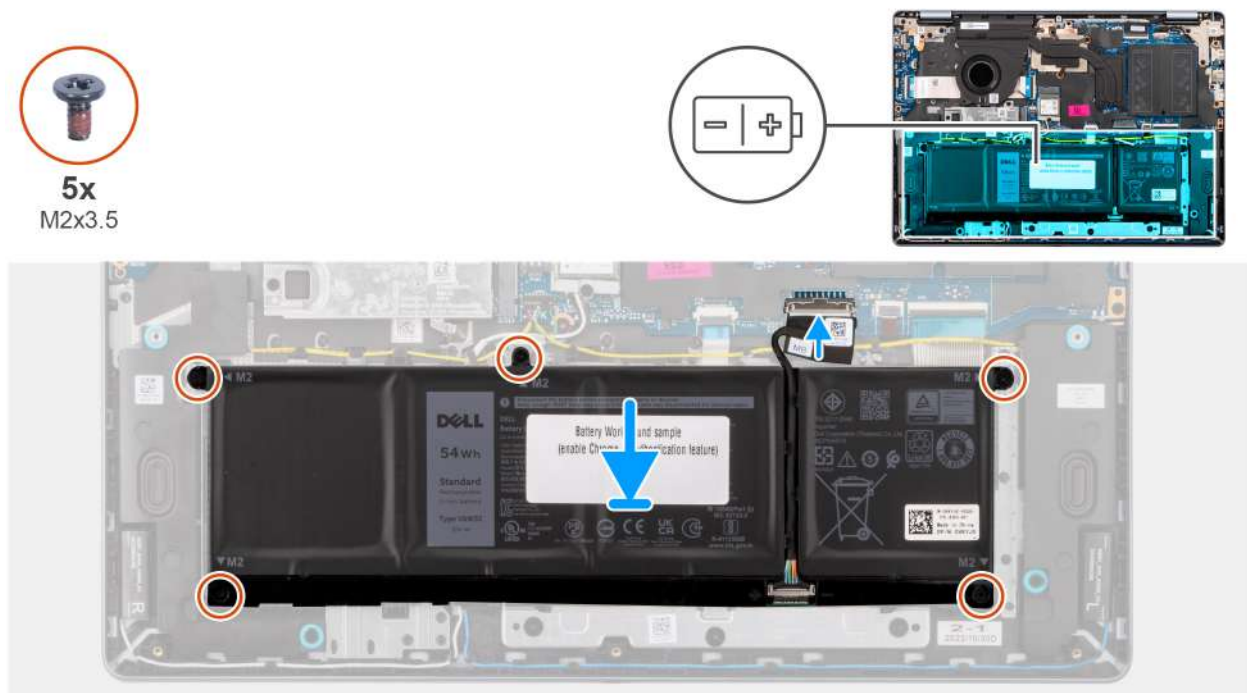

Figure 20. Installing the 4-cell battery

NOTE: Battery and battery cable are separate serviceable parts. If battery replacement is required, reuse the same battery cable. To connect the battery cable, see [Connecting the battery cable](#).

Steps

1. Place the battery, along with the battery cable, in the slot on the palm-rest and keyboard assembly.

NOTE: When placing the battery, insert the tabs on the battery into the hooks on the palm-rest and keyboard assembly.



Figure 21. Installing the battery - Insert the tabs into hooks

2. Align the screw holes on the battery with the screw holes on the palm-rest and keyboard assembly.
3. Replace the five screws (M2x3.5) to secure the battery to the palm-rest and keyboard assembly.
4. Connect the battery cable to the connector (BATT) on the system board.

Next steps

1. Install the [base cover](#).
2. Follow the procedure in [After working inside your computer](#).

Battery cable

Disconnecting the battery cable

Prerequisites

1. Follow the procedure in [Before working inside your computer](#).
2. Remove the [base cover](#).
3. Remove the [3-cell battery](#) or [4-cell battery](#), whichever is applicable.

About this task

The following images in the steps indicate the location of the battery cable and provide a visual representation of disconnecting the battery cable.

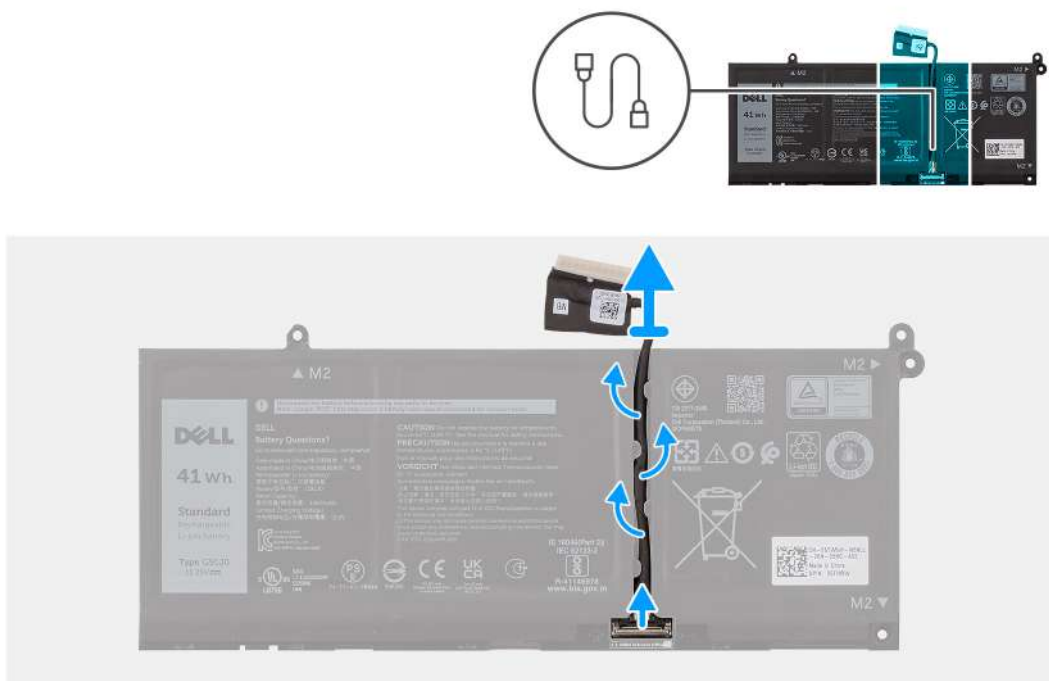

Figure 22. Disconnecting the battery cable

Steps

1. Remove the battery cable from the routing guides on the battery.
2. Open the latch and disconnect the battery cable from the connector on the battery.

CAUTION: Do not pull the battery cable to disconnect it from the battery. This may damage the battery or the battery cable.

NOTE: To disconnect the battery cable, first push the latch downward to release the connector, and then pull the connector upward to disconnect it from the battery.



Figure 23. Releasing the battery cable connector



Figure 24. Disconnecting the battery cable

Connecting the battery cable

Prerequisites

If you are replacing a component, remove the existing component before performing the installation procedure.

About this task

The following images in the steps indicate the location of the battery cable and provide a visual representation of the connecting the battery cable.

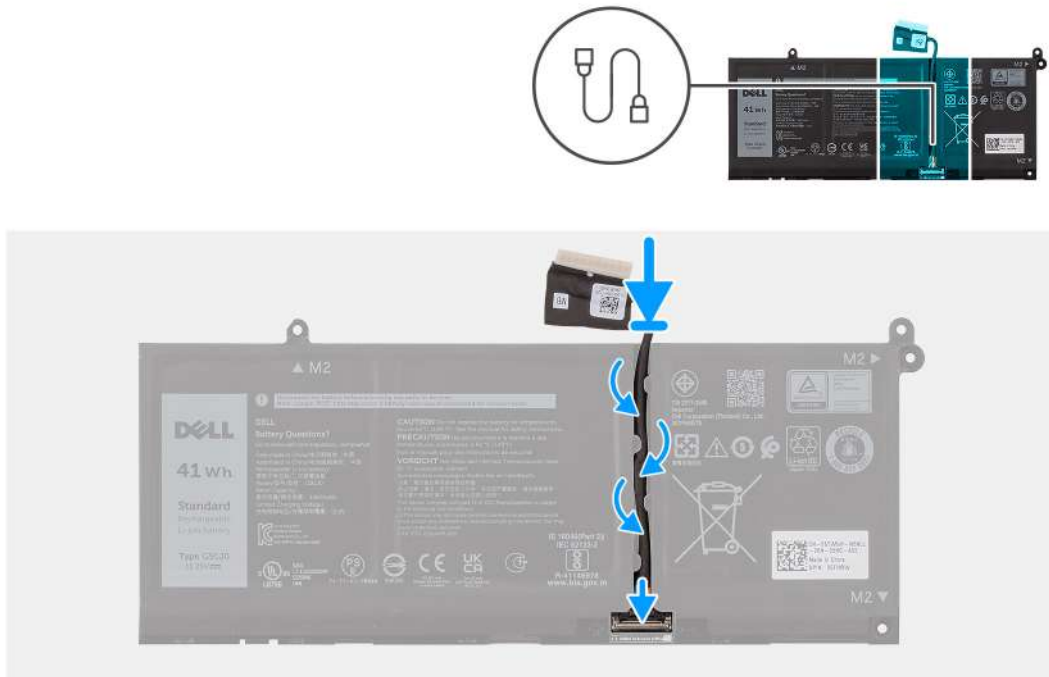

Figure 25. Connecting the battery cable

Steps

1. Connect the battery cable to the connector on the battery and close the latch.
2. Route the battery cable through the routing guides on the battery.

Next steps

1. Install the [3-cell battery](#) or [4-cell battery](#), whichever is applicable.
2. Install the [base cover](#).
3. Follow the procedure in [After working inside your computer](#).

Memory module

Removing the memory module

Prerequisites

1. Follow the procedure in [Before working inside your computer](#).
2. Remove the [base cover](#).

About this task

The following images indicate the location of the memory module and provide a visual representation of the removal procedure.

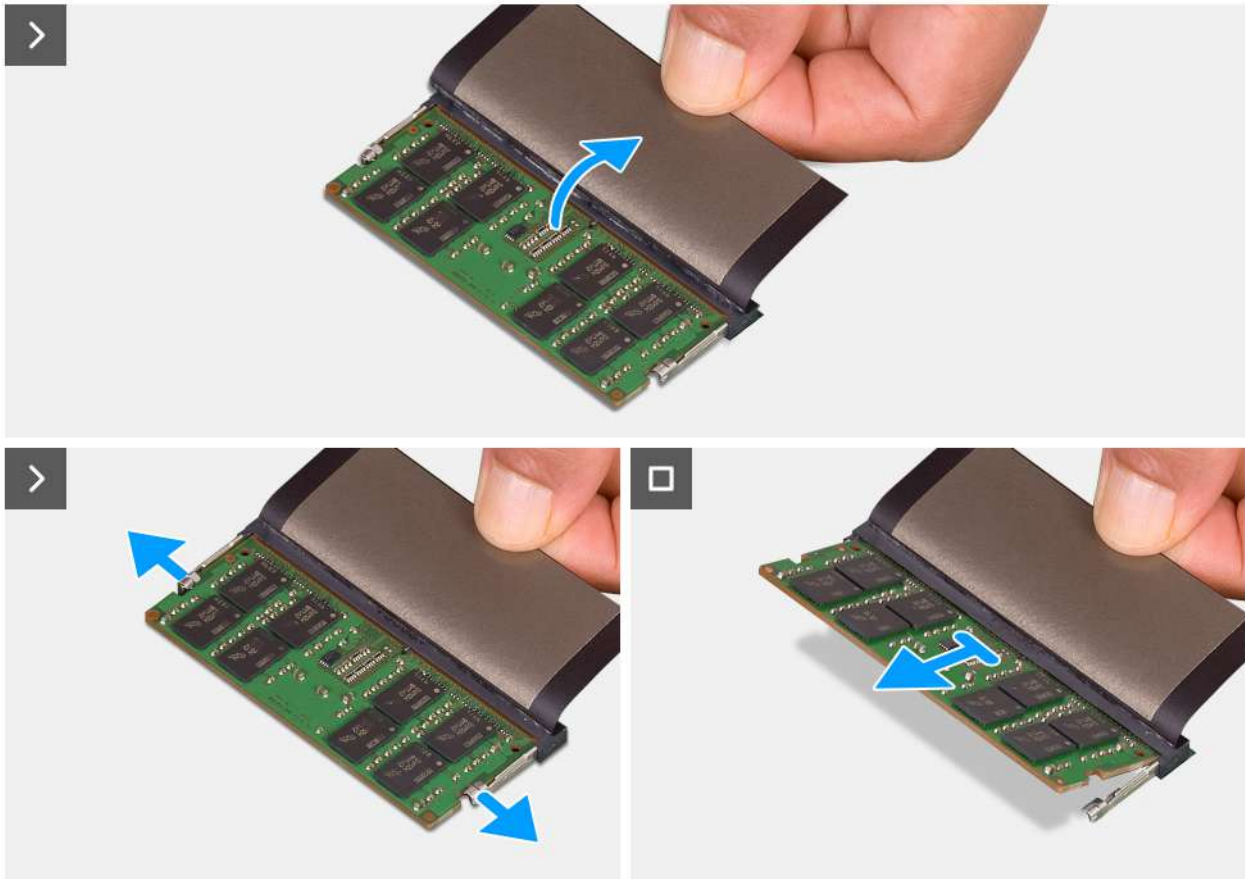
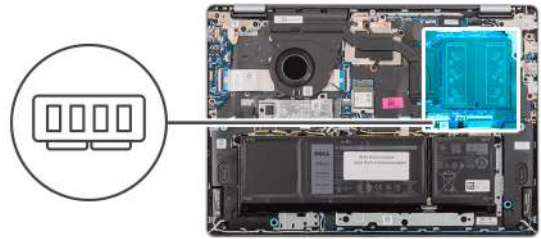

Figure 26. Removing the memory module

Steps

1. Lift the Mylar to access the memory module.
2. Pull the retention clips away from the memory module until the memory module pops-up.
3. Hold the memory module by the edges and slide to remove it from the memory-module slot (DIMM A DDR5 ONLY).

CAUTION: To prevent damage to the memory module, hold the memory module by the edges. Do not touch the components or metallic contacts on the memory module as electrostatic discharge (ESD) can inflict severe damage on the components. To read more about ESD protection, see [ESD protection](#).

4. Repeat step 1 to step 3 to remove the memory module from the second slot (DIMM B DDR5 ONLY), if installed.

Installing the memory module

Prerequisites

If you are replacing a component, remove the existing component before performing the installation procedure.

About this task

The following images indicate the location of the memory module and provide a visual representation of the installation procedure.

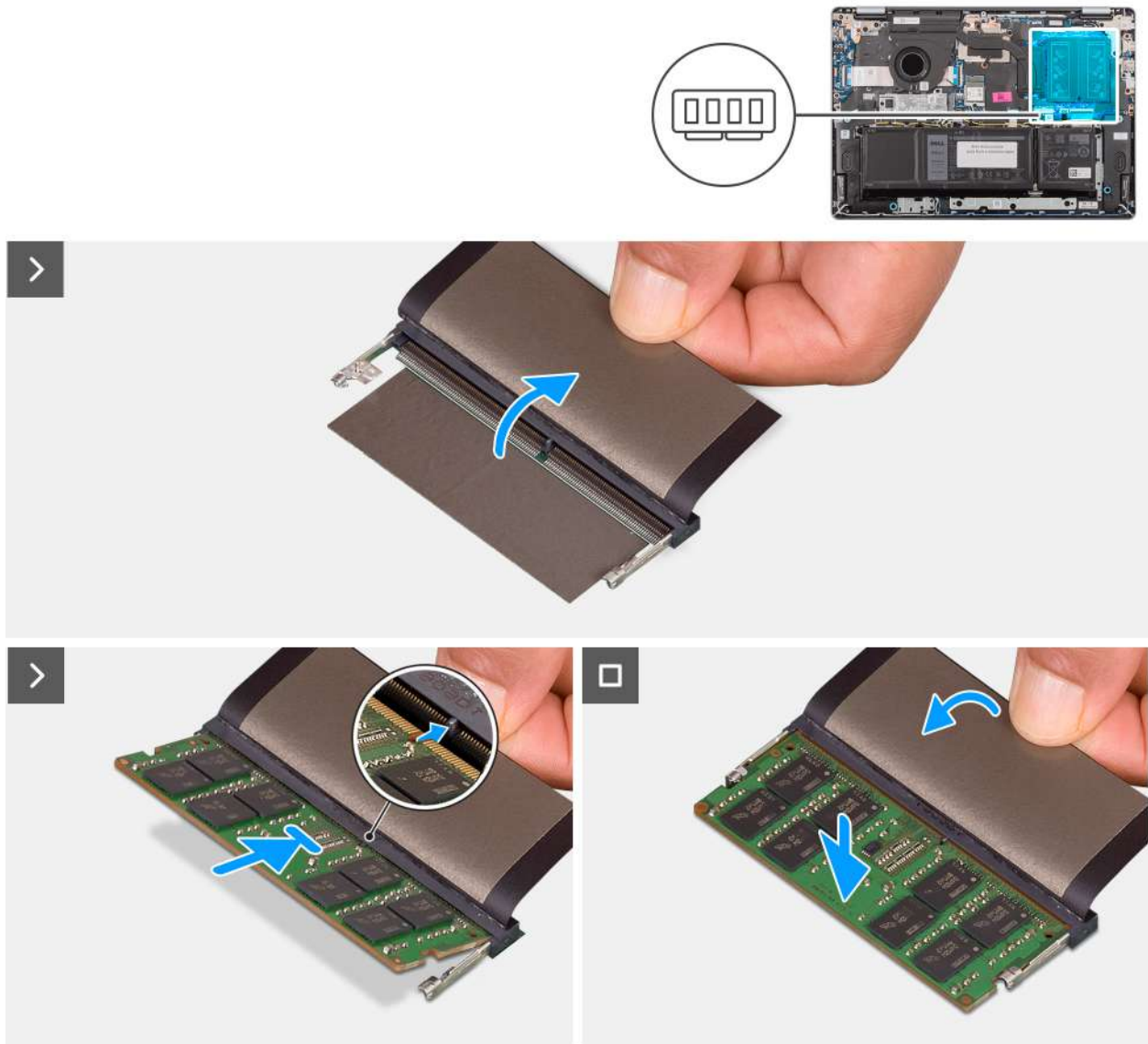

Figure 27. Installing the memory module

Steps

1. Lift the Mylar to access the memory-module slot.
2. Align the notch on the memory module to the tab on the memory-module slot (DIMM A DDR5 ONLY).
3. Slide the memory module firmly into the memory-module slot at an angle.
4. Press down on the memory module until the securing clips firmly click into place.

CAUTION: To prevent damage to the memory module, hold the memory module by the edges. Do not touch the components or metallic contacts on the memory module as electrostatic discharge (ESD) can inflict severe damage on the components. To read more about ESD protection, see [ESD protection](#).

NOTE: If you do not hear the click, remove the memory module and reinstall it.

5. Repeat step 1 to step 4 when installing the memory module in the second slot (DIMM B DDR5 ONLY).

Next steps

1. Install the [base cover](#).
2. Follow the procedure in [After working inside your computer](#).

Solid state drive

Removing the solid state drive

Prerequisites

1. Follow the procedure in [Before working inside your computer](#).
2. Remove the [base cover](#).

About this task

The following images indicate the location of the solid state drive and provide a visual representation of the removal procedure.

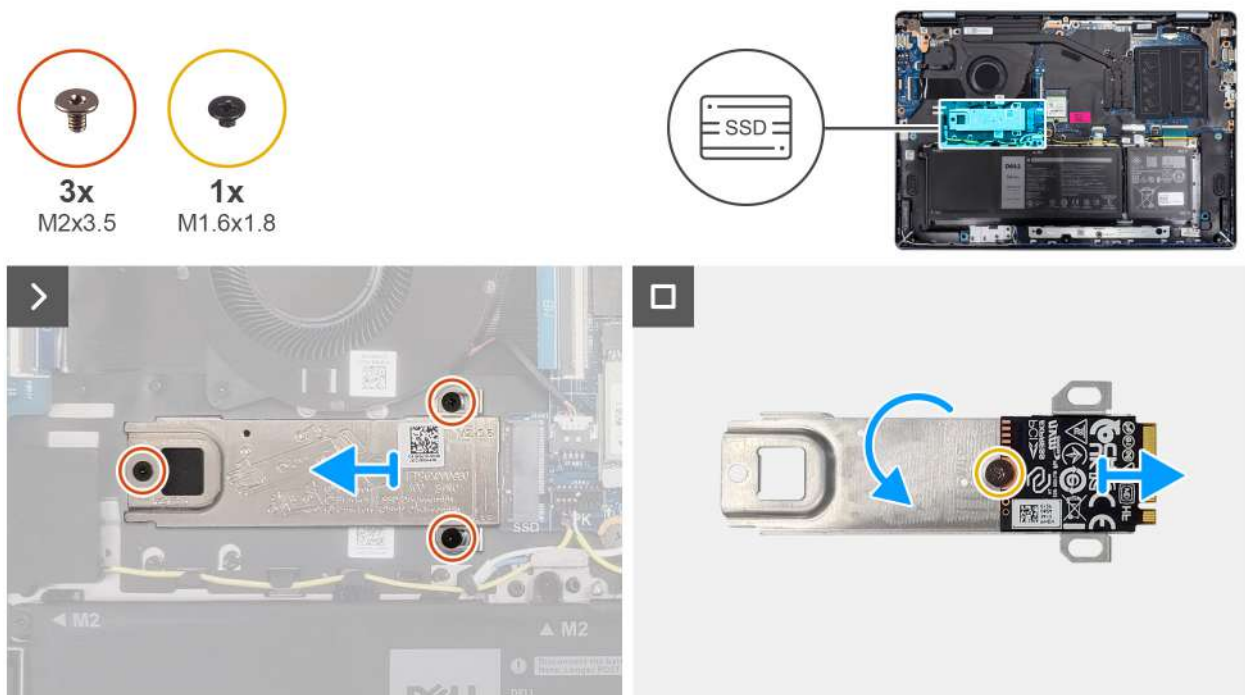

Figure 28. Removing the solid state drive

Steps

1. Remove the three screws (M2x3.5) that secure the solid state drive bracket and the solid state drive to the palm-rest and keyboard assembly.
2. Slide and remove the solid state drive bracket along with the solid state drive from the connector (SSD) on the system board.
3. Flip over the bracket and remove the screw (M1.6x1.8) that secures the solid state drive to the bracket.
4. Remove the solid state drive from the bracket.

Installing the solid state drive

Prerequisites

If you are replacing a component, remove the existing component before performing the installation procedure.

About this task

The following images indicate the location of the solid state drive and provide a visual representation of the installation procedure.

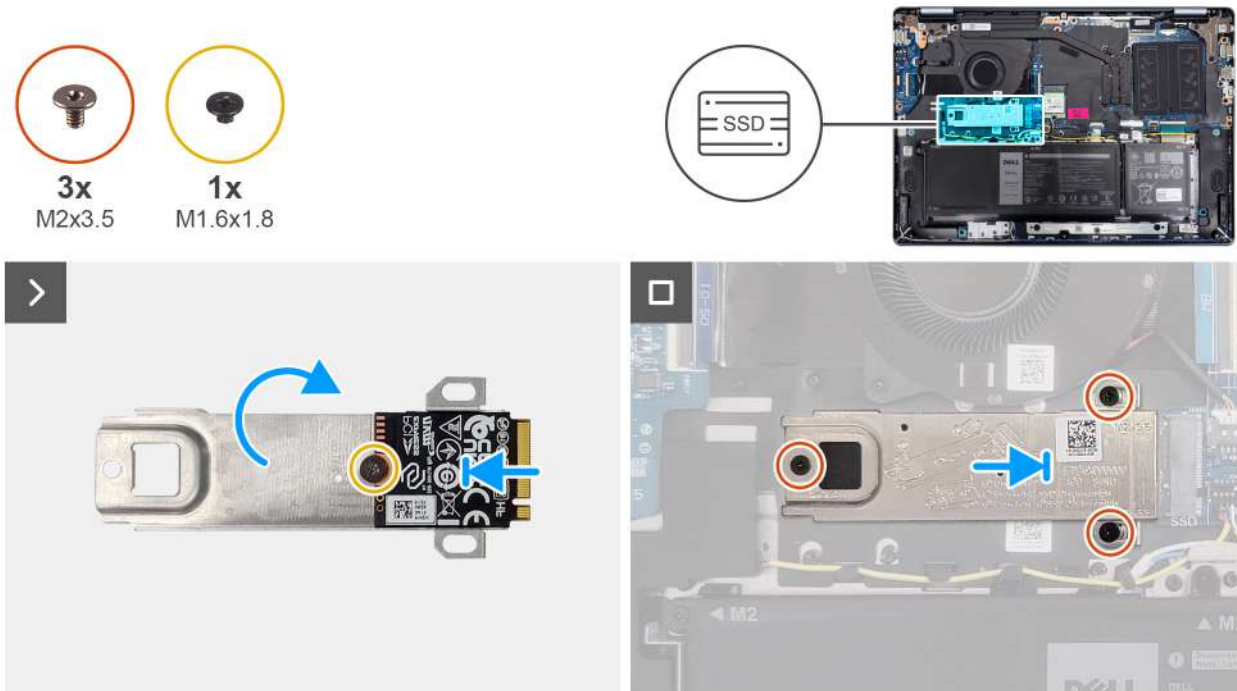

Figure 29. Installing the solid state drive

Steps

1. Align and place the solid state drive on the solid state drive bracket.
2. Replace the screw (M1.6x1.8) to secure the solid state drive to the bracket and flip the bracket.
3. Align the notch on the solid state drive to the tab on the M.2 card slot.
4. Slide the solid state drive bracket along with the solid state drive at an angle into the M.2 card slot (SSD) on the system board.
5. Align the screw holes on the solid state drive bracket with the screw holes on the palm-rest and keyboard assembly.
6. Replace the three screws (M2x3.5) to secure the solid state drive bracket and the solid state drive to the palm-rest and keyboard assembly.

Next steps

1. Install the [base cover](#).
2. Follow the procedure in [After working inside your computer](#).

Wireless card

Removing the wireless card

Prerequisites

1. Follow the procedure in [Before working inside your computer](#).
2. Remove the [base cover](#).

About this task

The following images indicate the location of the wireless card and provide a visual representation of the removal procedure.



1x
M2x3.5

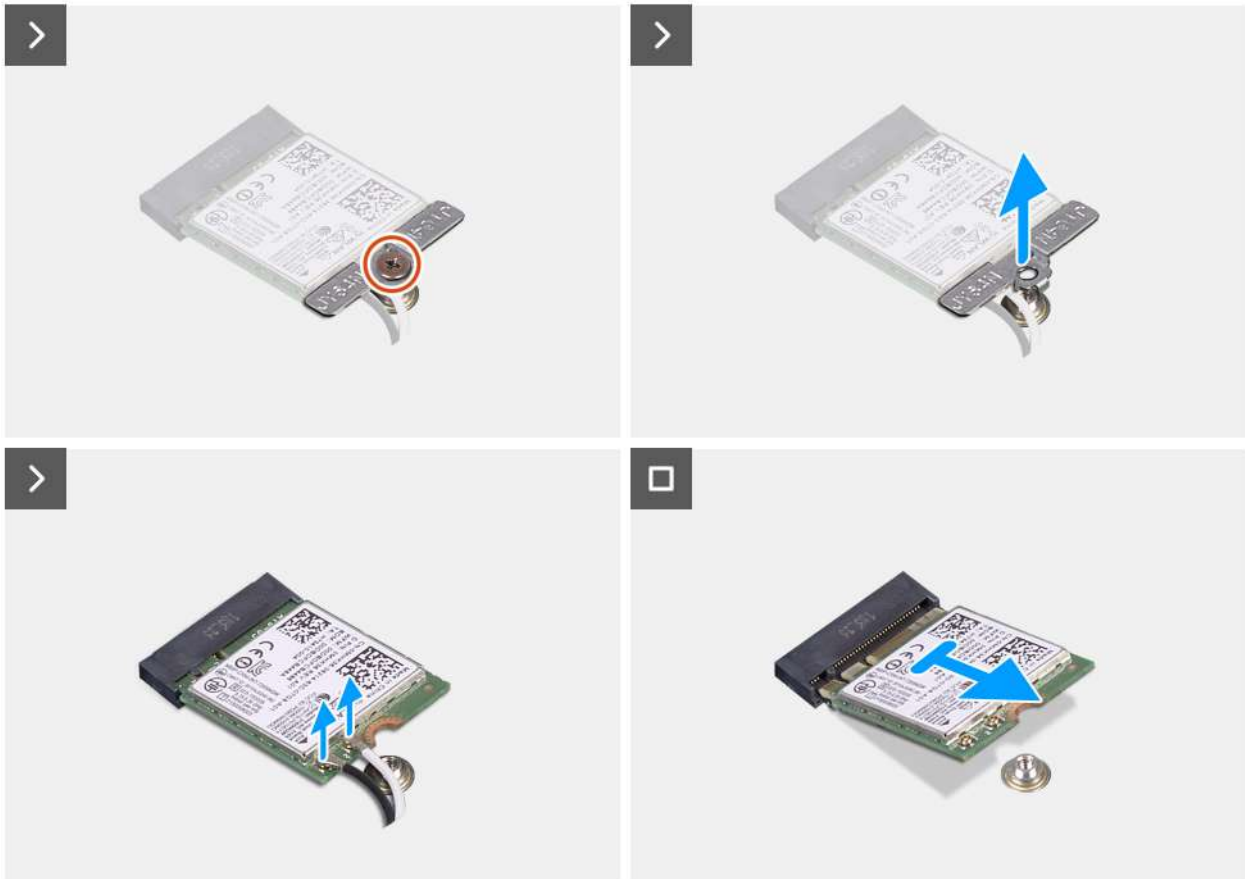

Figure 30. Removing the wireless card

Steps

1. Remove the screw (M2x3.5) that secures the wireless-card bracket to the system board.
2. Lift the wireless-card bracket off the wireless card.
3. Disconnect the wireless-antenna cables from the connectors on the wireless card.
4. Slide and remove the wireless card from the wireless-card slot (WLAN) on the system board.

Installing the wireless card

Prerequisites

If you are replacing a component, remove the existing component before performing the installation procedure.

About this task

The following images indicate the location of the wireless card and provide a visual representation of the installation procedure.



1x
M2x3.5

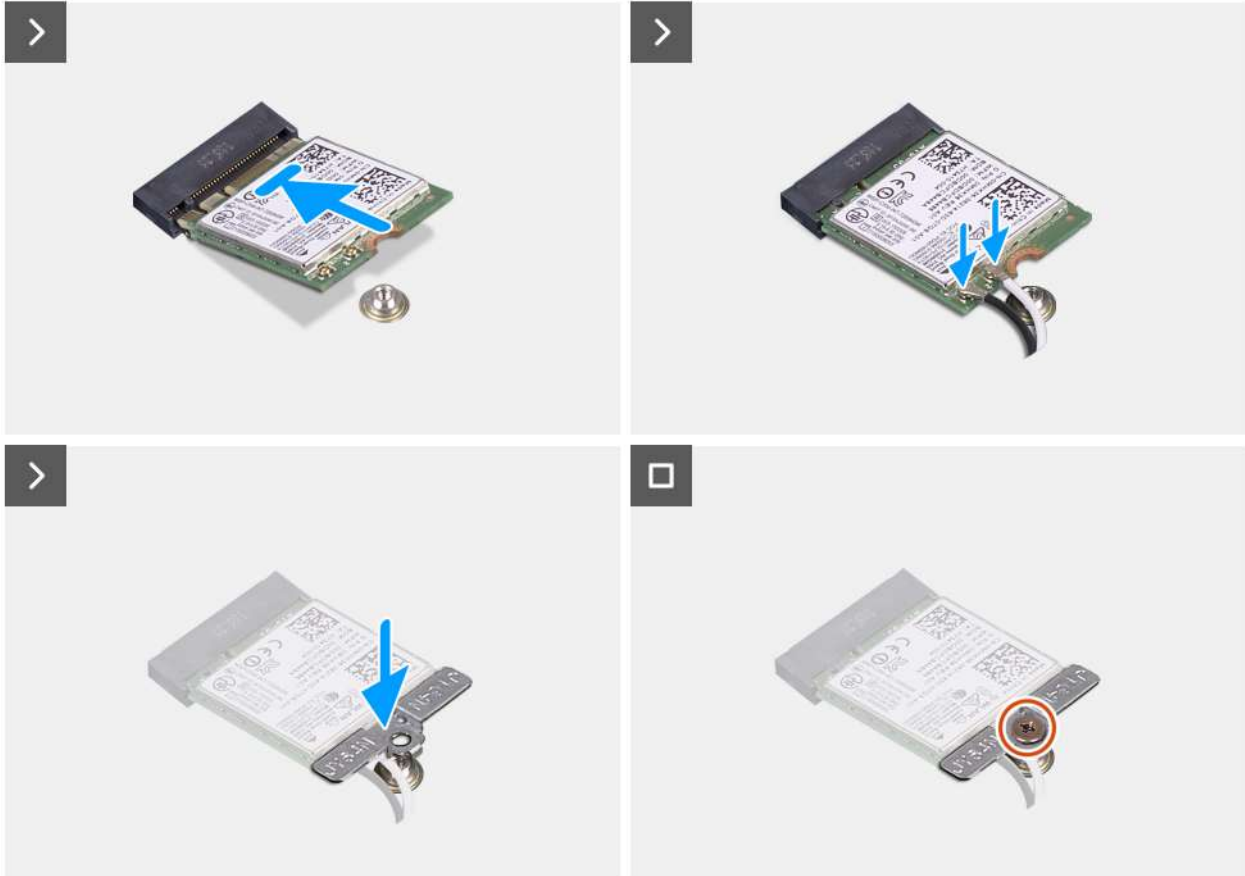

Figure 31. Installing the wireless card

Steps

1. Align the notch on the wireless card to the tab on the wireless-card slot.
2. Slide the wireless card at an angle into the wireless-card slot (WLAN) on the system board.
3. Connect the wireless-antenna cables to the connectors on the wireless card.

The following table provides the antenna-cable color scheme for the wireless card that is supported by your computer.

Table 30. Antenna-cable color scheme

Connector on the wireless card	Antenna-cable color	Silkscreen marking	
Main	White	MAIN	△ (white triangle)
Auxiliary	Black	AUX	▲ (black triangle)

4. Place the wireless-card bracket on the wireless card.
5. Align the screw hole on the wireless-card bracket with the screw hole on the system board.
6. Replace the screw (M2x3.5) to secure the wireless-card bracket and the wireless card to the system board.

Next steps

1. Install the [base cover](#).
2. Follow the procedure in [After working inside your computer](#).

Speakers

Removing the speakers

Prerequisites

1. Follow the procedure in [Before working inside your computer](#).
2. Remove the [base cover](#).

About this task

The following images indicate the location of the speakers and provide a visual representation of the removal procedure.

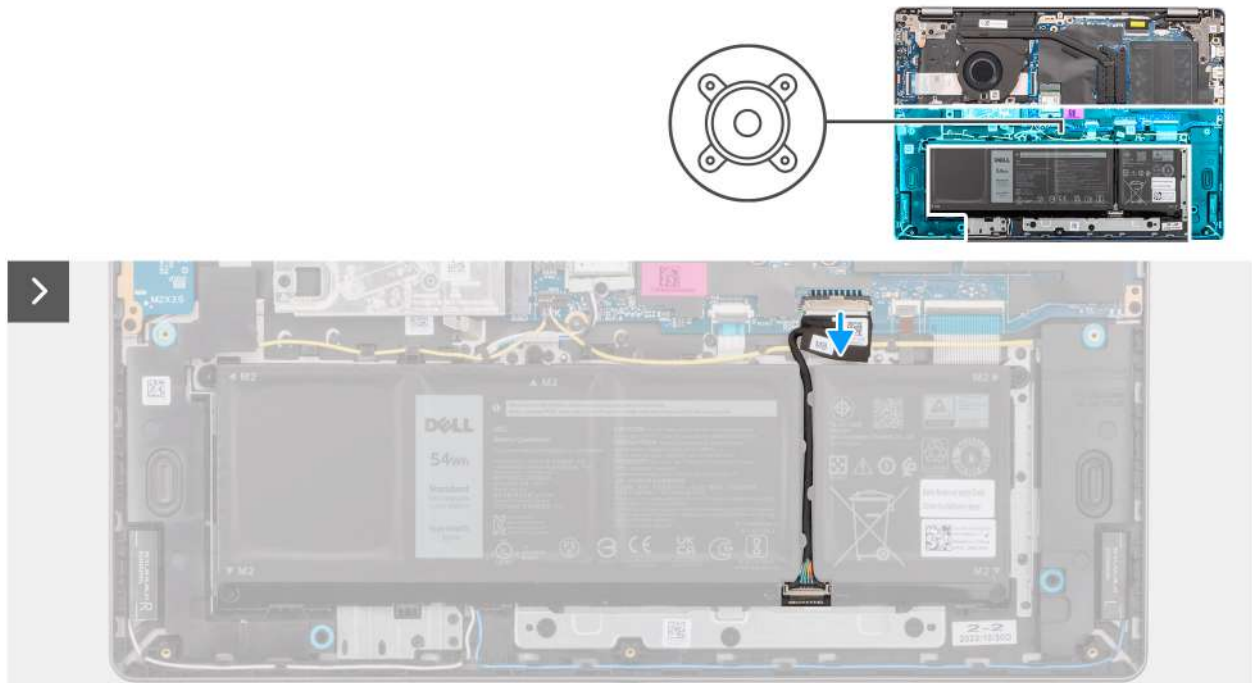

Figure 32. Disconnecting the battery cable



4x
M2x2.3

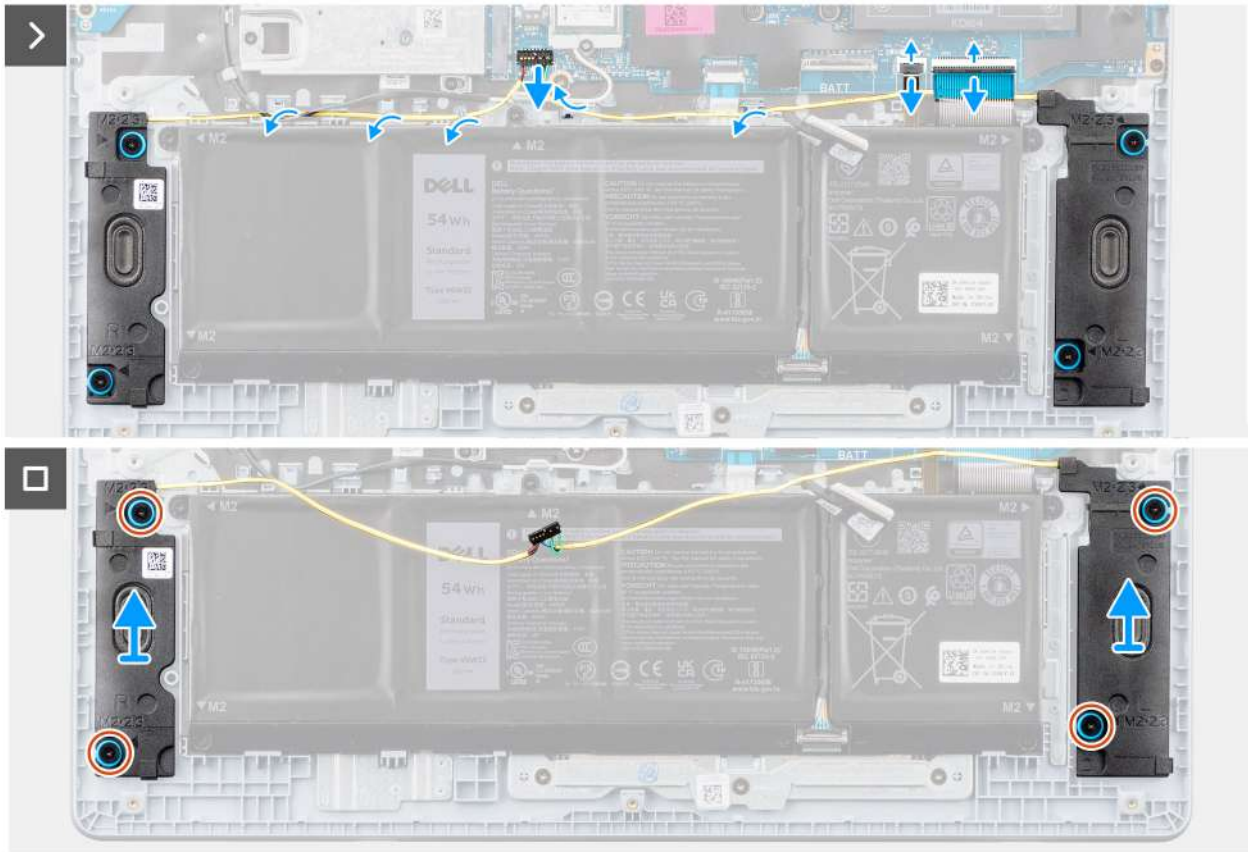

Figure 33. Removing the speakers

Steps

1. Disconnect the battery cable from the connector (BATT) on the system board.
2. Disconnect the keyboard cable and keyboard-backlight cable from the connectors (KB) and (BL) on the system board to allow unrouting of the speaker cable.
3. Disconnect the speaker cable from the connector (SPK) on the system board.

CAUTION: To disconnect the speaker cable from the system board, pry the base of the cable connector's head first and then pull it away from the connector (SPK) on the system board. Do not pull the cable downwards to disconnect the speaker cable from the system board.

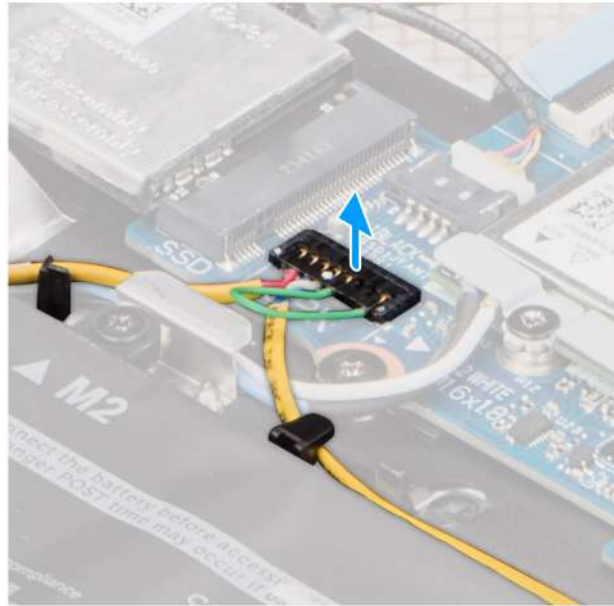

Figure 34. Disconnecting the speaker cable

4. Remove the speaker cable from the routing guides on palm-rest and keyboard assembly.
5. Remove the four screws (M2x2.3) that secure the speakers to the palm-rest and keyboard assembly.
6. Lift the speakers, along with the cable, off the palm-rest and keyboard assembly.

Installing the speakers

Prerequisites

If you are replacing a component, remove the existing component before performing the installation procedure.

About this task

The following images indicate the location of the speakers and provide a visual representation of the installation procedure.



4x
M2x2.3



Figure 35. Installing the speakers

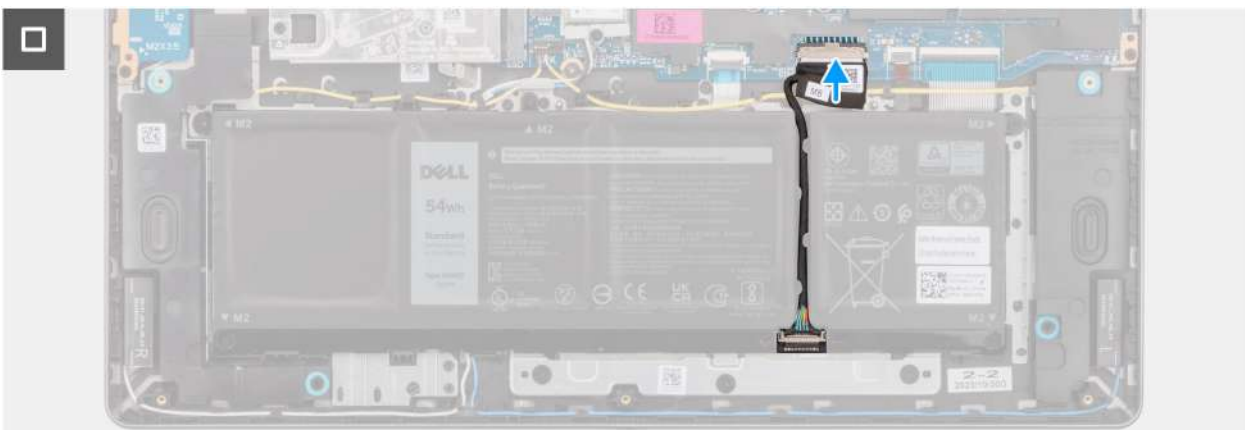

Figure 36. Connecting the battery cable

NOTE: If the rubber grommets are pushed out when removing the speakers, push them back in before replacing the speakers.

Steps

1. Using the alignment posts and rubber grommets, place the speakers in the slots on the palm-rest and keyboard assembly.
NOTE: Ensure that the rubber grommets on the speakers are threaded through the alignment posts and the four rubber grommets are seated into the slot and installed on the speakers properly.

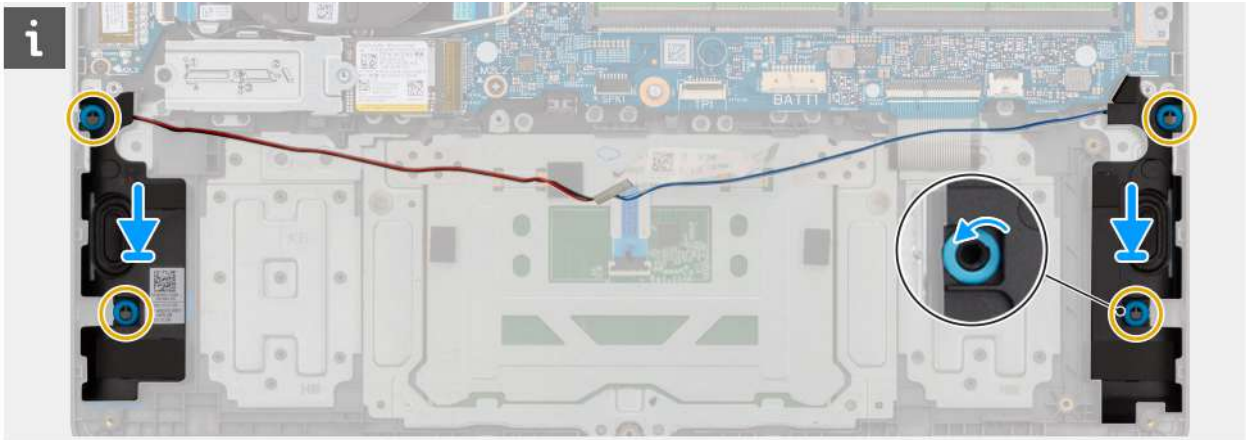

Figure 37. Aligning the speaker grommets

2. Replace the four screws (M2x2.3) to secure the speakers to the palm-rest and keyboard assembly.
3. Route the speaker cable through the routing guides on the palm-rest and keyboard assembly, over the wireless-antenna cables.
4. Connect the speaker cable to the connector (SPK) on the system board.
5. Connect the keyboard cable to the connector (KB) on the system board.
6. Connect the keyboard-backlight cable to the connector (BL) on the system board.
7. Connect the battery cable to the connector (BATT) on the system board.

Next steps

1. Install the [base cover](#).
2. Follow the procedure in [After working inside your computer](#).

Fan

Removing the fan

Prerequisites

1. Follow the procedure in [Before working inside your computer](#).
2. Remove the [base cover](#).

About this task

The following image indicates the location of the fan and provides a visual representation of the removal procedure.



Figure 38. Removing the fan

Steps

1. Disconnect the fan cable from the connector (FAN) on the system board.
2. Remove the two screws (M2x5.5) that secure the fan to the palm-rest and keyboard assembly.
3. Lift the fan, along with the fan cable, off the palm-rest and keyboard assembly.

Installing the fan

Prerequisites

If you are replacing a component, remove the existing component before performing the installation procedure.

About this task

The following image indicates the location of the fan and provides a visual representation of the installation procedure.

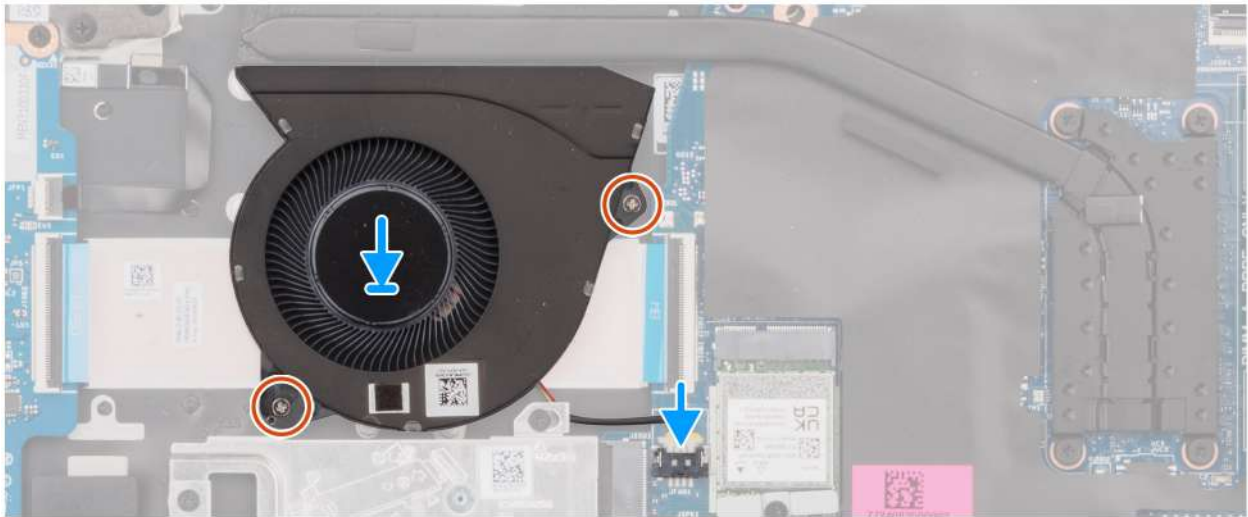

Figure 39. Installing the fan

Steps

1. Align and place the fan, along with fan cable, in the slot on the palm-rest and keyboard assembly.

 **CAUTION: Avoid touching the fan blades to prevent damage.**

2. Align the screw holes on the fan with the screw holes on the palm-rest and keyboard assembly.
3. Replace the two screws (M2x5.5) to secure the fan to the palm-rest and keyboard assembly.
4. Connect the fan cable to the connector (FAN) on the system board.

Next steps

1. Install the [base cover](#).
2. Follow the procedure in [After working inside your computer](#).

Removing and installing Field Replaceable Units (FRUs)

The replaceable components in this chapter are Field Replaceable Units (FRUs).

CAUTION: The information in this section is intended for authorized service technicians only.

CAUTION: To avoid any potential damage to the component or loss of data, ensure that an authorized service technician replaces the Field Replaceable Units (FRUs).

CAUTION: Dell Technologies recommends that these procedures be performed by trained technical repair specialists.

CAUTION: Your warranty does not cover damages that may occur during FRU repairs that are not authorized by Dell Technologies.

NOTE: The images in this document may differ from your computer depending on the configuration you ordered.

Heat sink

Removing the heat sink - for computers shipped with integrated graphics card

CAUTION: The information in this section is intended for authorized service technicians only.

Prerequisites

1. Follow the procedure in [Before working inside your computer](#).
2. Remove the [base cover](#).

About this task

The following image indicates the location of the heat sink and provides a visual representation of the removal procedure.



4x

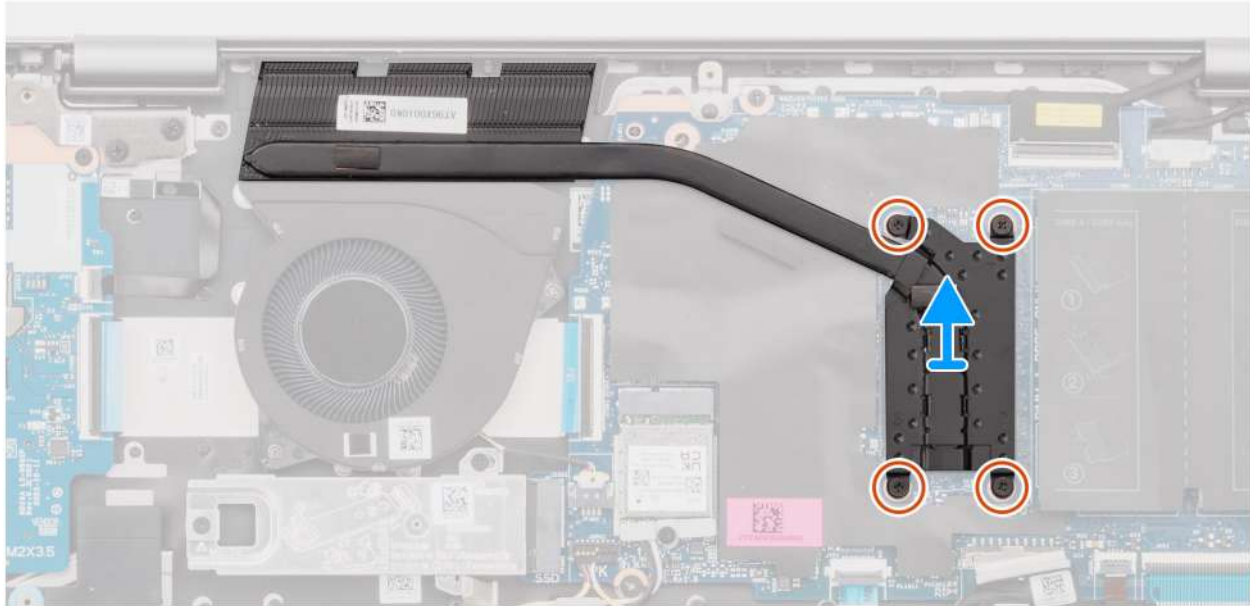

Figure 40. Removing the heat sink - for computers shipped with integrated graphics card

WARNING: The heat sink may become hot during normal operation. Allow sufficient time for the heat sink to cool before you touch it.

CAUTION: Do not touch the heat-transfer areas on the heat sink. The oils in your skin can reduce the heat-transfer capability of the thermal grease.

Steps

1. In reverse sequential order (4 → 3 → 2 → 1), loosen the four captive screws that secure the heat sink to the system board.

NOTE: The screw numbers are etched on the heat sink.

2. Lift the heat sink off the system board.

Installing the heat sink - for computers shipped with integrated graphics card

CAUTION: The information in this section is intended for authorized service technicians only.

Prerequisites

If you are replacing a component, remove the existing component before performing the installation procedure.

About this task

The following image indicates the location of the heat sink and provides a visual representation of the installation procedure.

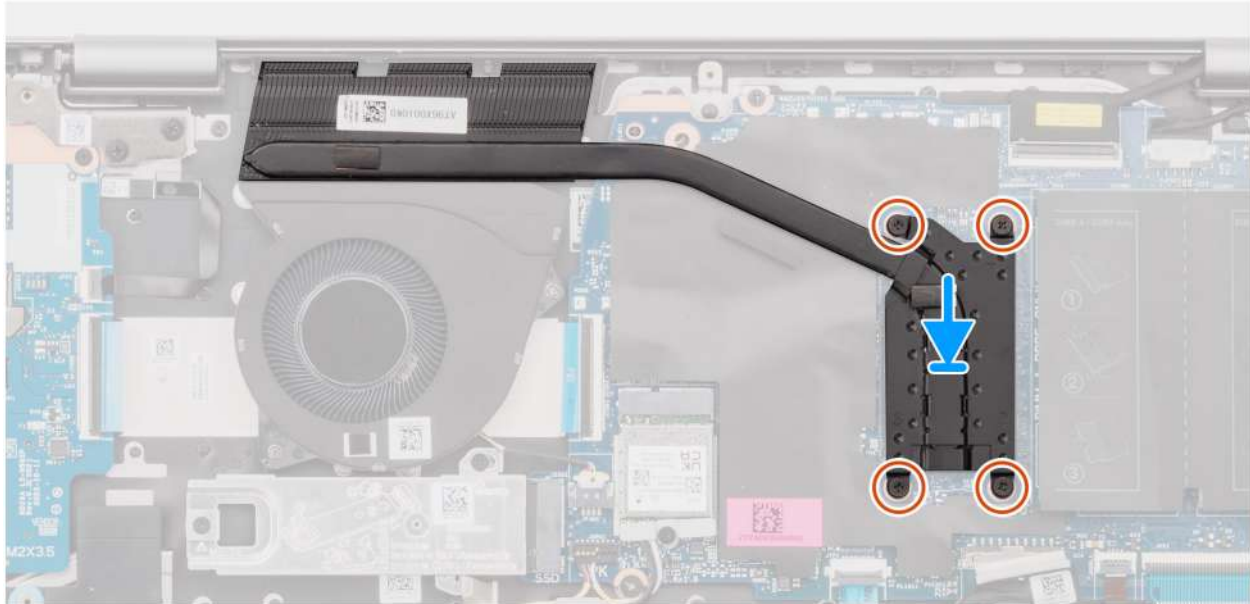

Figure 41. Installing the heat sink - for computers shipped with integrated graphics card

NOTE: If either the system board or the heat sink is replaced, use the thermal grease that is provided in the kit to ensure that thermal conductivity is achieved.

Steps

1. Place the heat sink in the slot on the system board.
2. Align the screw holes on the heat sink with the screw holes on the system board.
3. In sequential order (1 → 2 → 3 → 4), tighten the four captive screws to secure the heat sink to the system board.

NOTE: The screw numbers are etched on the heat sink.

Next steps

1. Install the [base cover](#).
2. Follow the procedure in [After working inside your computer](#).

Removing the heat sink - for computers shipped with discrete graphics card

CAUTION: The information in this section is intended for authorized service technicians only.

Prerequisites

1. Follow the procedure in [Before working inside your computer](#).
2. Remove the [base cover](#).

About this task

The following image indicates the location of the heat sink and provides a visual representation of the removal procedure.

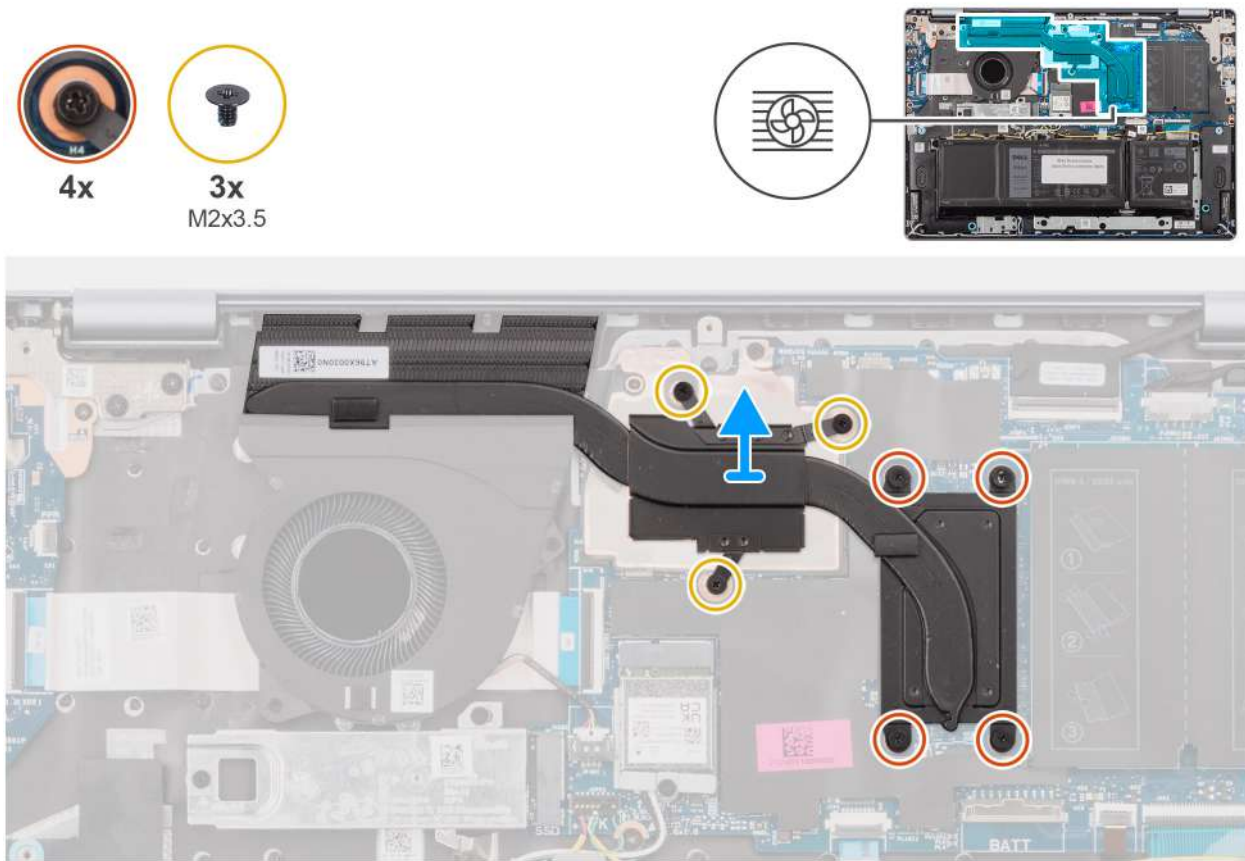

Figure 42. Removing the heat sink - for computers shipped with discrete graphics card

WARNING: The heat sink may become hot during normal operation. Allow sufficient time for the heat sink to cool before you touch it.

CAUTION: Do not touch the heat-transfer areas on the heat sink. The oils in your skin can reduce the heat-transfer capability of the thermal grease.

Steps

1. In reverse sequential order (7 → 6 → 5 → 4 → 3 → 2 → 1), loosen the four captive screws and remove the three screws (M2x3.5) that secure the heat sink to the system board.

NOTE: The screw numbers are etched on the heat sink.

NOTE: Screws numbered 1 to 3 are removable and those numbered 4 to 7 are captive.

2. Lift the heat sink off the system board.

Installing the heat sink - for computers shipped with discrete graphics card

CAUTION: The information in this section is intended for authorized service technicians only.

Prerequisites

If you are replacing a component, remove the existing component before performing the installation procedure.

About this task

The following image indicates the location of the heat sink and provides a visual representation of the installation procedure.

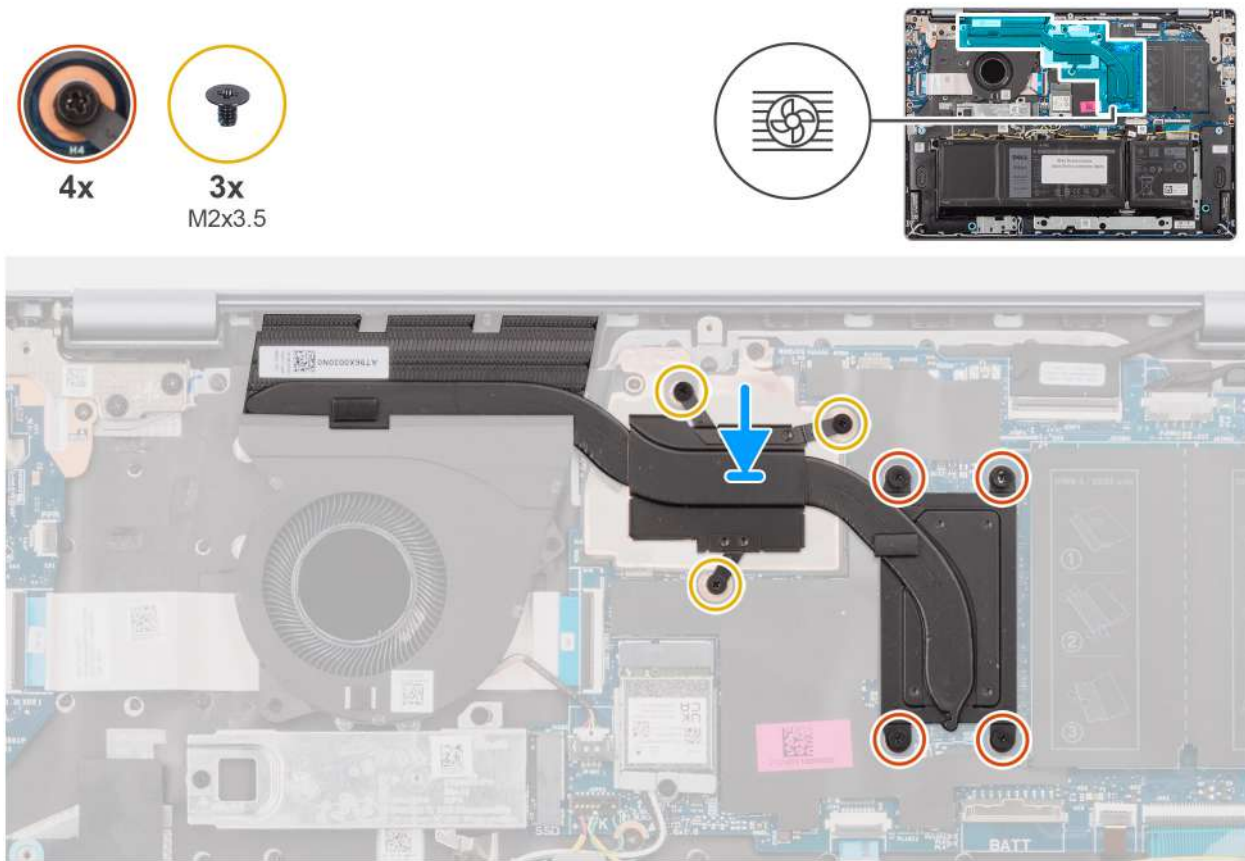

Figure 43. Installing the heat sink - for computers shipped with a discrete graphics card

NOTE: If either the system board or the heat sink is replaced, use the thermal grease provided in the kit to ensure that thermal conductivity is achieved.

Steps

1. Place the heat sink in the slot on the system board.
2. Align the screw holes on the heat sink with the screw holes on the system board.
3. In sequential order (1 → 2 → 3 → 4 → 5 → 6 → 7), tighten the four captive screws and replace the three screws (M2x3.5) to secure the heat sink to the system board.

NOTE: The screw numbers are etched on the heat sink.

NOTE: Screws numbered 1 to 3 are removable and those numbered 4 to 7 are captive.

Next steps

1. Install the [base cover](#).
2. Follow the procedure in [After working inside your computer](#).

Touchpad

Removing the touchpad

CAUTION: The information in this section is intended for authorized service technicians only.

Prerequisites

1. Follow the procedure in [Before working inside your computer](#).
2. Remove the [base cover](#).
3. Remove the [3-cell battery](#) or [4-cell battery](#), whichever is applicable.

About this task

The following images indicate the location of the touchpad and provide a visual representation of the removal procedure.

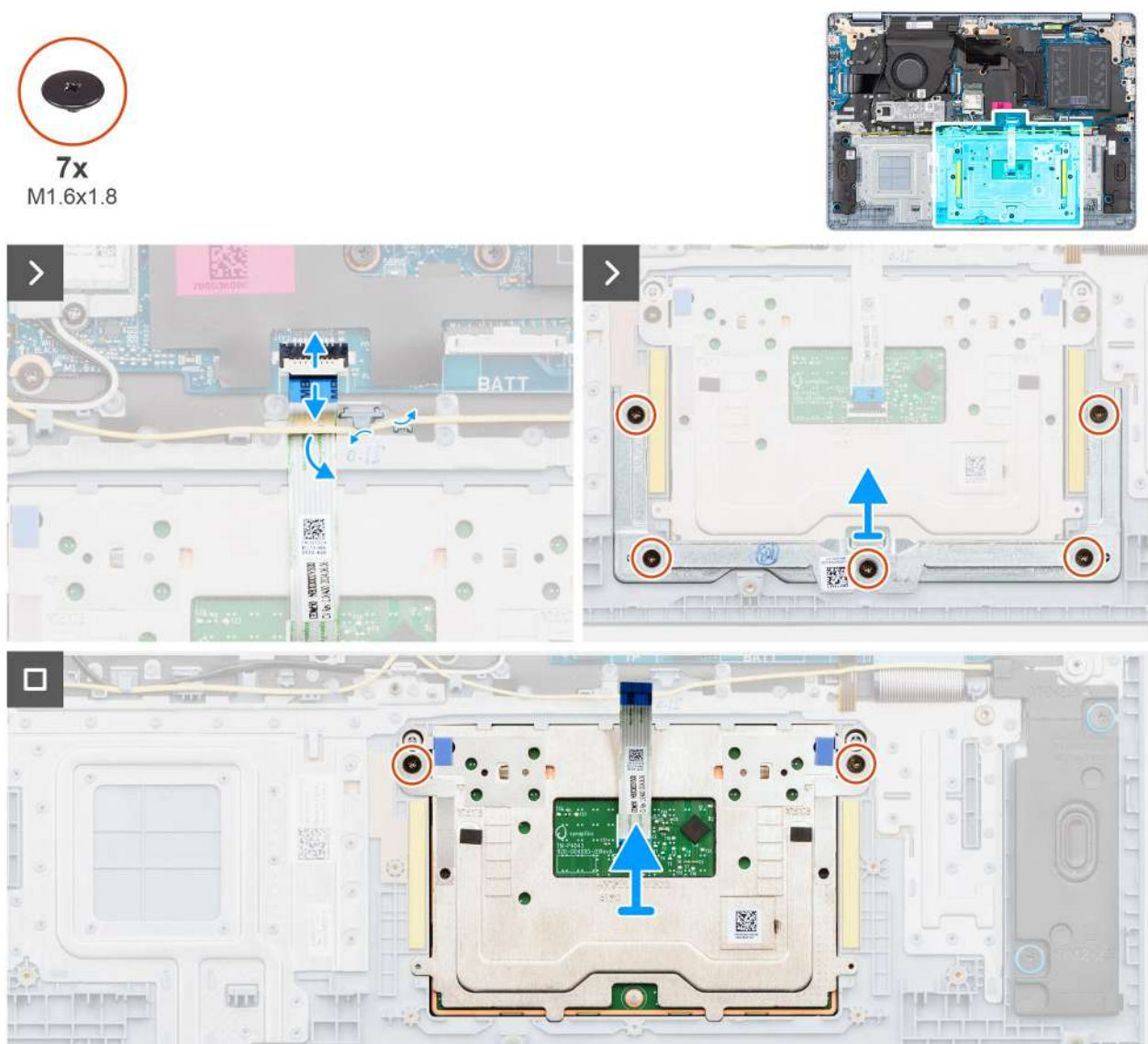



Figure 44. Removing the touchpad

Steps

1. Remove the speaker cable from the routing guides on the palm-rest and keyboard assembly.

2. Open the latch and disconnect the touchpad cable from the connector (TP) on the system board.
3. Slide and remove the touchpad cable from underneath the speaker cable.
4. Remove the five screws (M1.6x1.8) that secure the touchpad bracket to the palm-rest and keyboard assembly.
5. Lift the touchpad bracket off the touchpad.
6. Remove the two screws (M1.6x1.8) that secure the touchpad to the palm-rest and keyboard assembly.
7. Lift the touchpad, along with the touchpad cable, off the palm-rest and keyboard assembly.

 **NOTE:** The touchpad cable is assembled with the touchpad assembly as a service part and must not be removed from the touchpad assembly.

Installing the touchpad

 **CAUTION:** The information in this section is intended for authorized service technicians only.

Prerequisites

If you are replacing a component, remove the existing component before performing the installation procedure.

About this task

The following images indicate the location of the touchpad and provide a visual representation of the installation procedure.

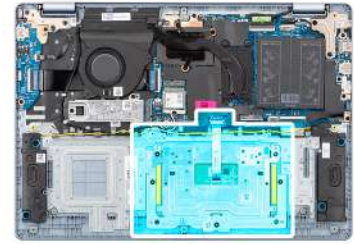

Figure 45. Installing the touchpad

NOTE: Ensure that the touchpad is aligned with the guides on the palm-rest and keyboard assembly, and the gap on either side of the touchpad is equal.

Steps

1. Align and place the touchpad, along with the touchpad cable, in the slot on the palm-rest and keyboard assembly.
2. Replace the two screws (M1.6x1.8) to secure the touchpad to the palm-rest and keyboard assembly.
3. Place the touchpad bracket in the slot on the palm-rest and keyboard assembly.
4. Align the screw holes on the touchpad bracket with the screw holes on the palm-rest and keyboard assembly.
5. Replace the five screws (M1.6x1.8) to secure the touchpad bracket to the palm-rest and keyboard assembly.
6. Slide the touchpad cable underneath the speaker cable.
7. Connect the touchpad cable to the connector (TP) on the system board and close the latch.
8. Route the speaker cable through the routing guides on the palm-rest and keyboard assembly.

Next steps

1. Install the [3-cell battery](#) or [4-cell battery](#), whichever is applicable.
2. Install the [base cover](#).
3. Follow the procedure in [After working inside your computer](#).

I/O-board cable

Removing the I/O-board cable

CAUTION: The information in this section is intended for authorized service technicians only.

Prerequisites

1. Follow the procedure in [Before working inside your computer](#).
2. Remove the [base cover](#).
3. Remove the [fan](#).

About this task

The following image indicates the location of the I/O-board cable and provides a visual representation of the removal procedure.

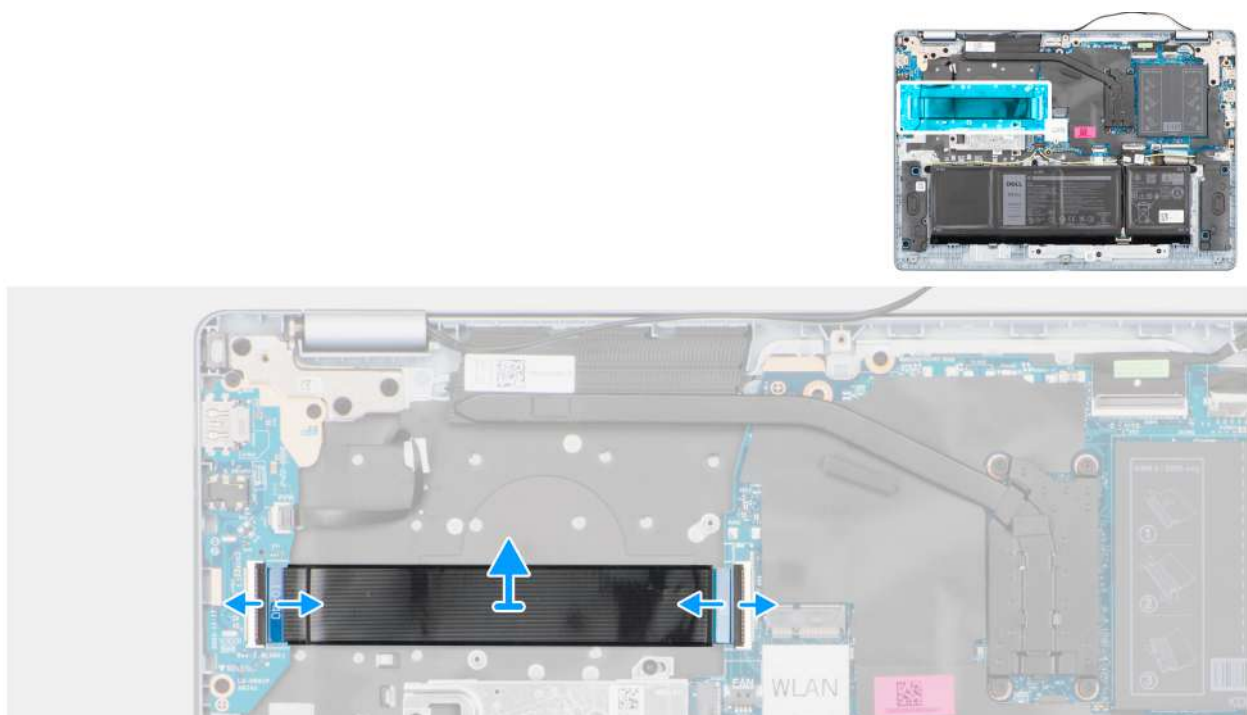

Figure 46. Removing the I/O-board cable

Steps

1. Open the latch and disconnect the I/O-board cable from the connector (IO) on the system board.
2. Open the latch and disconnect the I/O-board cable from the connector on the I/O-board.
3. Remove the I/O-board cable from the palm-rest and keyboard assembly.

Installing the I/O-board cable

CAUTION: The information in this section is intended for authorized service technicians only.

Prerequisites

If you are replacing a component, remove the existing component before performing the installation procedure.

About this task

The following image indicates the location of the I/O-board cable and provides a visual representation of the installation procedure.

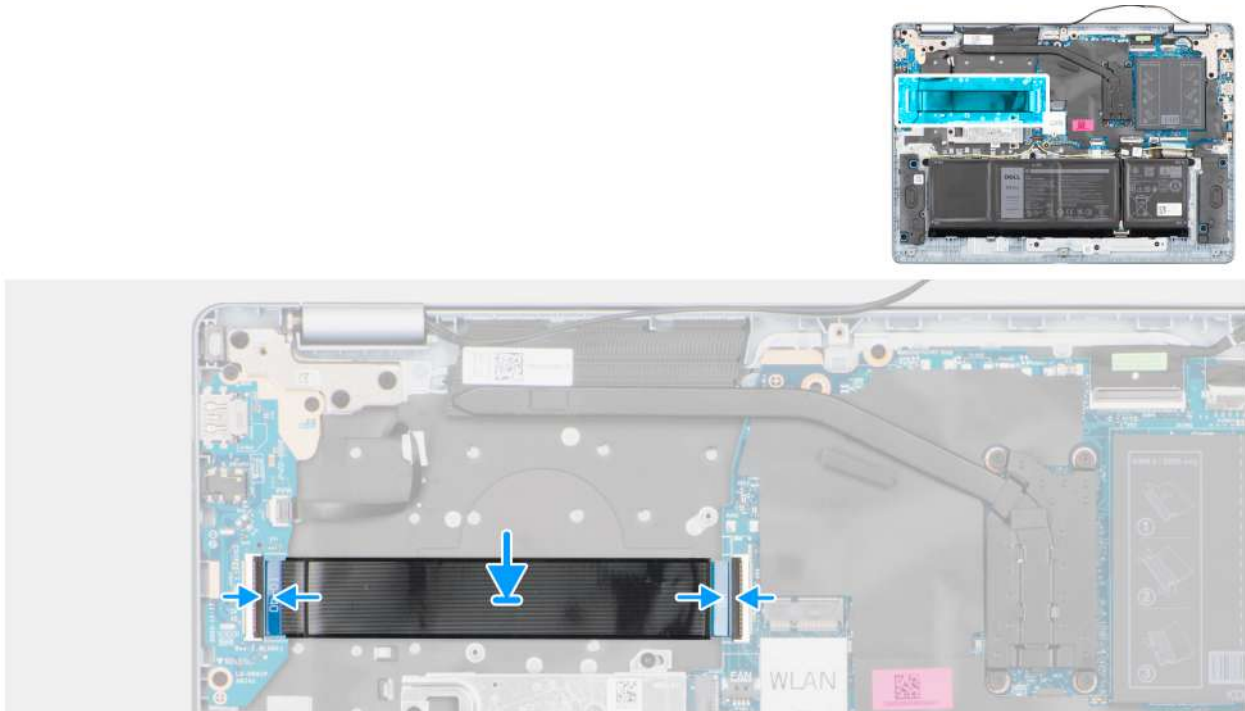

Figure 47. Installing the I/O-board cable

Steps

1. Place the I/O-board cable on the palm-rest and keyboard assembly.
2. Connect the I/O-board cable to the connector on the I/O board and close the latch.
3. Connect the I/O-board cable to the connector (IO) on the system board and close the latch.

Next steps

1. Install the [fan](#).
2. Install the [base cover](#).
3. Follow the procedure in [After working inside your computer](#).

I/O board

Removing the I/O board

CAUTION: The information in this section is intended for authorized service technicians only.

Prerequisites

1. Follow the procedure in [Before working inside your computer](#).
2. Remove the [base cover](#).

About this task

The following images indicate the location of the I/O board and provide a visual representation of the removal procedure.

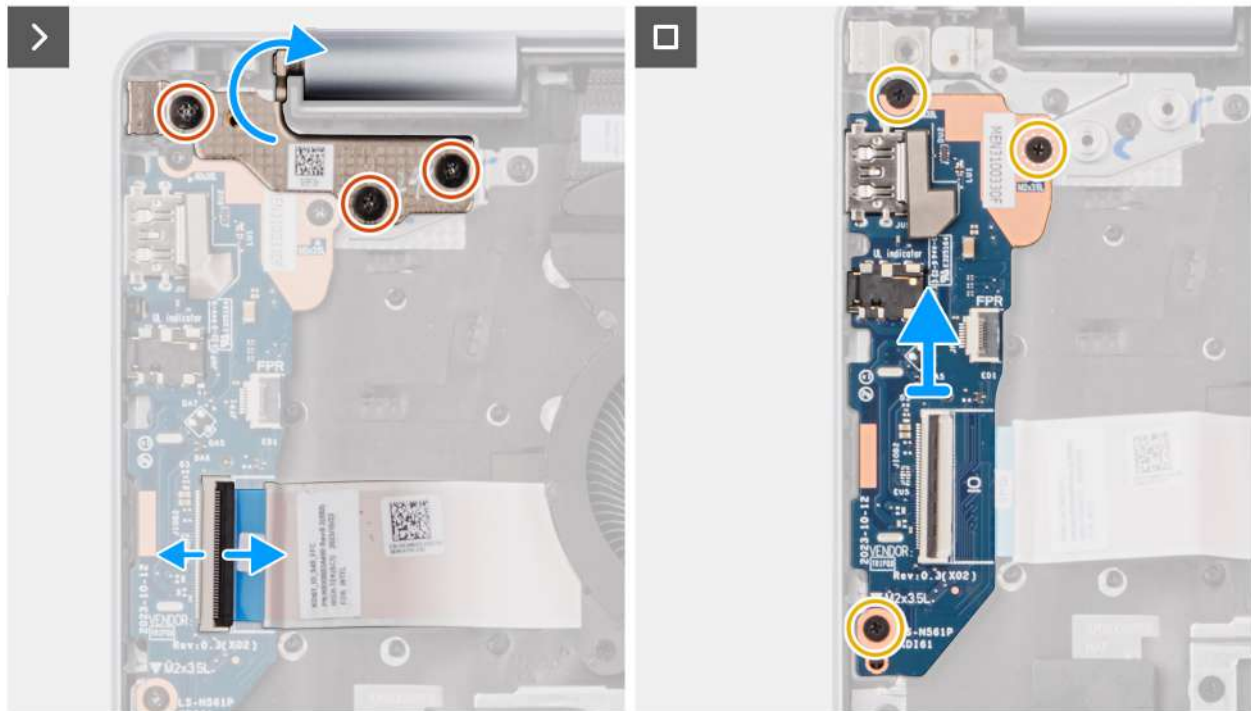

Figure 48. Removing the I/O board

Steps

1. Remove the three screws (M2.5x5) that secure the right-display hinge to the palm-rest and keyboard assembly.
2. Using a plastic scribe, lift and open the right-display hinge to an angle of 90 degrees from the palm-rest and keyboard assembly to access the I/O board.
3. Open the latch and disconnect the I/O-board cable from the connector on the I/O board.
4. For computers shipped with fingerprint reader installed, open the latch and disconnect the fingerprint-reader cable from the I/O board.
5. Remove the three screws (M2x3.5) that secure the I/O board to the palm-rest and keyboard assembly.
6. Carefully slide and lift the I/O board at an angle, moving it away from the port slots, and then remove it from the palm-rest and keyboard assembly.

Installing the I/O board

CAUTION: The information in this section is intended for authorized service technicians only.

Prerequisites

If you are replacing a component, remove the existing component before performing the installation procedure.

About this task

The following images indicate the location of the I/O board and provide a visual representation of the installation procedure.

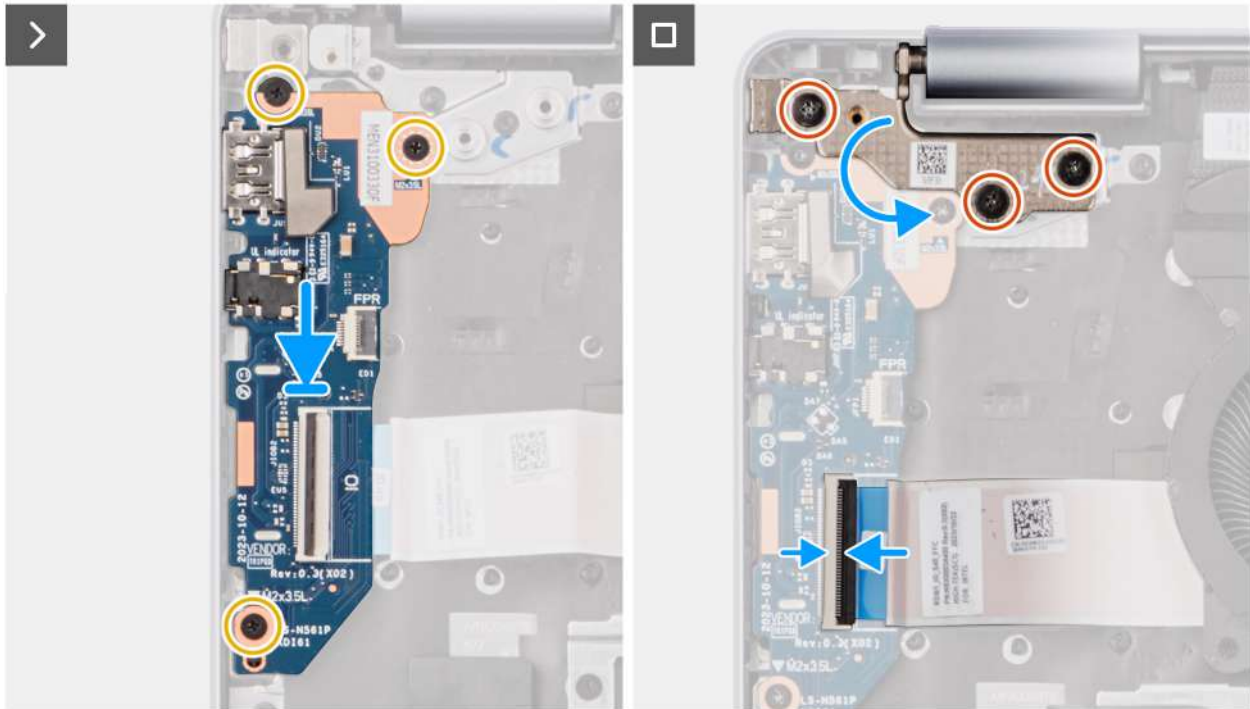

Figure 49. Installing the I/O board

Steps

1. Carefully slide and place the I/O board on the palm-rest and keyboard assembly.
2. Align the ports on the I/O board with the port slots on the palm-rest and keyboard assembly.
3. Replace the three screws (M2x3.5) to secure the I/O board to the palm-rest and keyboard assembly.
4. For computers shipped with fingerprint reader installed, connect the fingerprint-reader cable to the connector on the I/O board and close the latch.
5. Connect the I/O-board cable to the connector on the I/O board and close the latch.
6. Close the right-display hinge to align the screw holes of the right-display hinge to the screw holes on the palm-rest and keyboard assembly.
7. Replace the three screws (M2.5x5) to secure the right-display hinge to the palm-rest and keyboard assembly.

Next steps

1. Install the [base cover](#).
2. Follow the procedure in [After working inside your computer](#).

Display assembly

Removing the display assembly

CAUTION: The information in this section is intended for authorized service technicians only.

NOTE: The maximum operating angle for the display-panel hinge is 135 degrees.

Prerequisites

1. Follow the procedure in [Before working inside your computer](#).
2. Remove the [base cover](#).
3. Remove the [wireless card](#).

About this task

The following images indicate the location of the display assembly and provide a visual representation of the removal procedure.

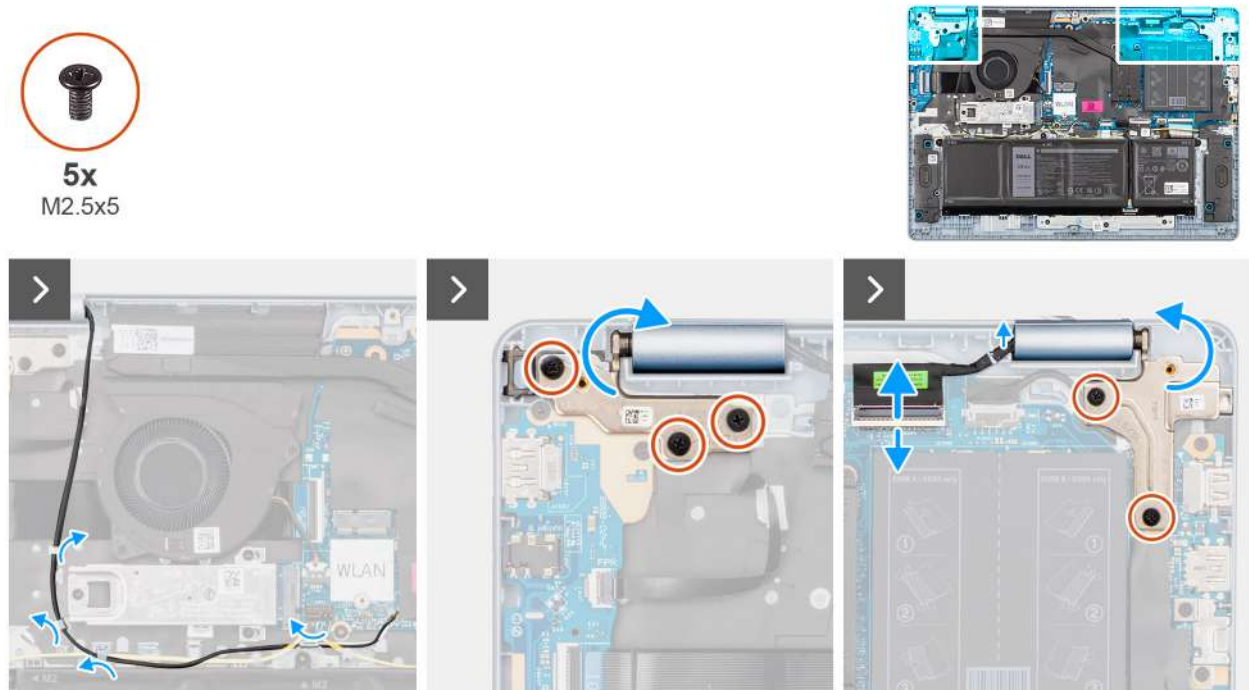

Figure 50. Removing the display assembly



Figure 51. Removing the display assembly

Steps

1. Remove the speaker cable from the routing guides on the palm-rest and keyboard assembly.
2. Remove the wireless-antenna cables from the routing guides on the palm-rest and keyboard assembly.
3. Remove the five screws (M2.5x5) that secure the left and right-display hinges to the palm-rest and keyboard assembly.
4. Using a plastic scribe, lift the display hinges to an angle of 90 degrees from the palm-rest and keyboard assembly.
5. Disconnect the display cable from the connector (eDP) on the system board.
6. Remove the display cable from the routing guides on the palm-rest and keyboard assembly.
7. Lift the palm-rest and keyboard assembly at an angle to free it from the hinges and remove it from the display assembly.

NOTE: The power-adapter port is secured in place by the left-display hinge. There is no screw, tape, or adhesive that secures the power-adapter port to the palm-rest and keyboard assembly. Therefore, it is important to verify that the power-adapter port has not been displaced during subsequent replacement procedures.

Installing the display assembly

CAUTION: The information in this section is intended for authorized service technicians only.

NOTE: The maximum operating angle for the display-panel hinge is 135 degrees.

Prerequisites

If you are replacing a component, remove the existing component before performing the installation procedure.

About this task

The following images indicate the location of the display assembly and provide a visual representation of the installation procedure.



5x
M2.5x5

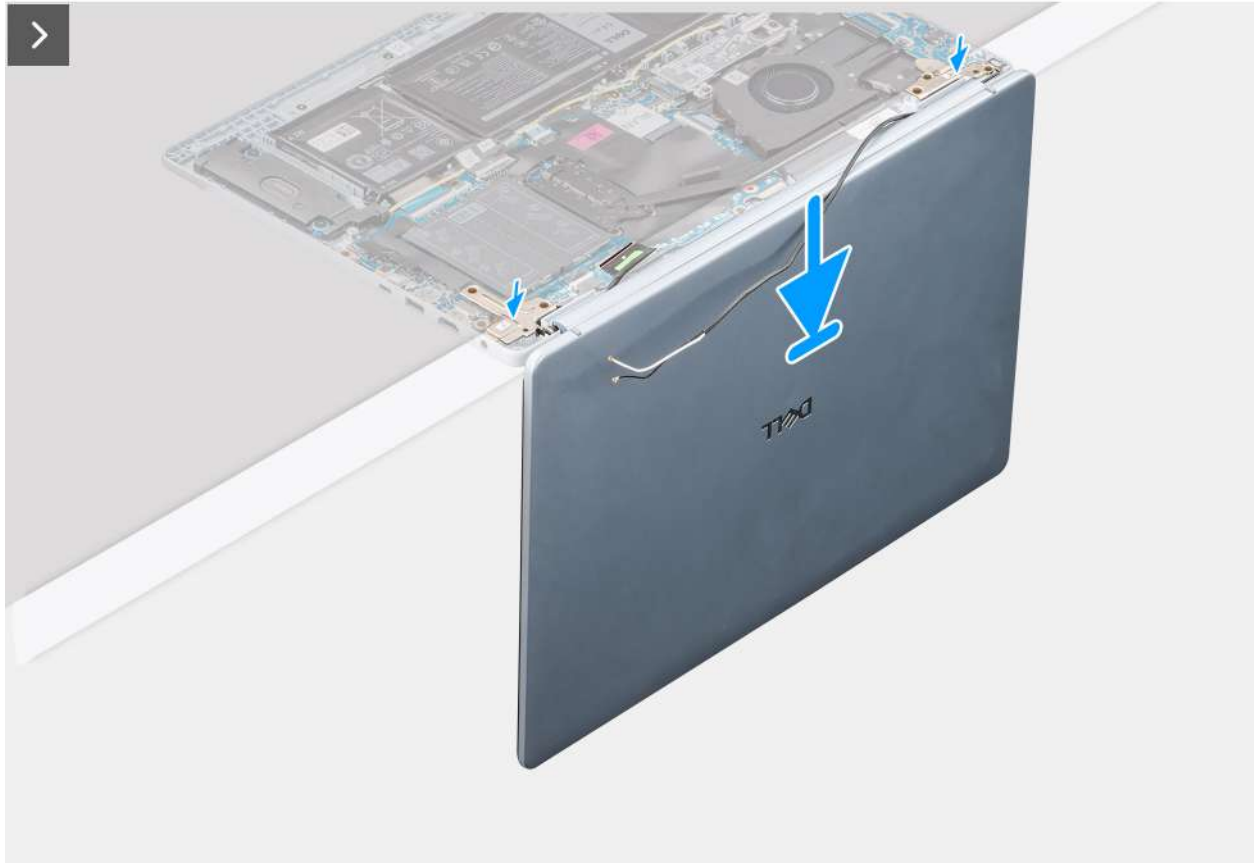

Figure 52. Installing the display assembly

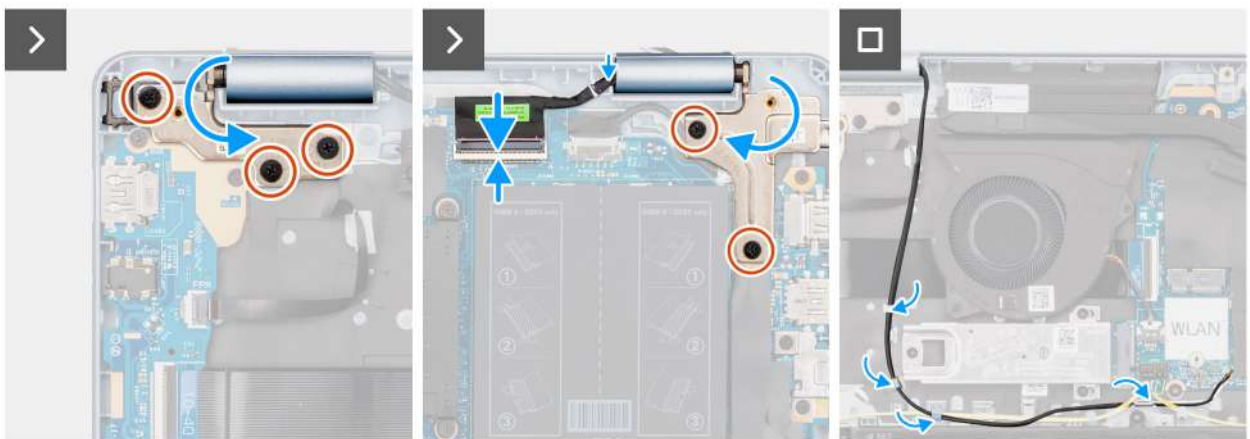



Figure 53. Installing the display assembly

NOTE: Ensure that the display hinges are opened to the maximum before replacing the display assembly on the palm-rest and keyboard assembly.

Steps

1. Place the display assembly on a clean and flat surface.
2. Carefully place the palm-rest and keyboard assembly at an angle on the display assembly.

 **CAUTION:** Do not slide the palm-rest and keyboard assembly over the display assembly to avoid damaging the display.

 **NOTE:** The power-adapter port is secured in place by the left-display hinge. There is no screw, tape, or adhesives that secure the power-adapter port to the palm-rest and keyboard assembly. Therefore, it is important to verify that the power-adapter port has not been displaced during subsequent replacement procedures.

3. Gently press to close the hinges and align the screw holes on the hinges with the screw holes on the palm-rest and keyboard assembly.
4. Replace the five screws (M2.5x5) to secure the left and right-display hinges to the palm-rest and keyboard assembly.
5. Route the display cable through the routing guides on the palm-rest and keyboard assembly.
6. Connect the display cable to the connector (eDP) on the system board.
7. Route the wireless-antenna cables through the routing guides over the palm-rest and keyboard assembly.
8. Route the speaker cable through the routing guides on the palm-rest and keyboard assembly.

Next steps

1. Install the [wireless card](#).
2. Install the [base cover](#).
3. Follow the procedure in [After working inside your computer](#).

Display bezel

Removing the display bezel

 **CAUTION:** The information in this section is intended for authorized service technicians only.

 **NOTE:** The display-hinge caps are a part of the display bezel.

Prerequisites

1. Follow the procedure in [Before working inside your computer](#).
2. Remove the [base cover](#).
3. Remove the [wireless card](#).
4. Remove the [display assembly](#).

About this task

The following images indicate the location of the display bezel and provide a visual representation of the removal procedure.

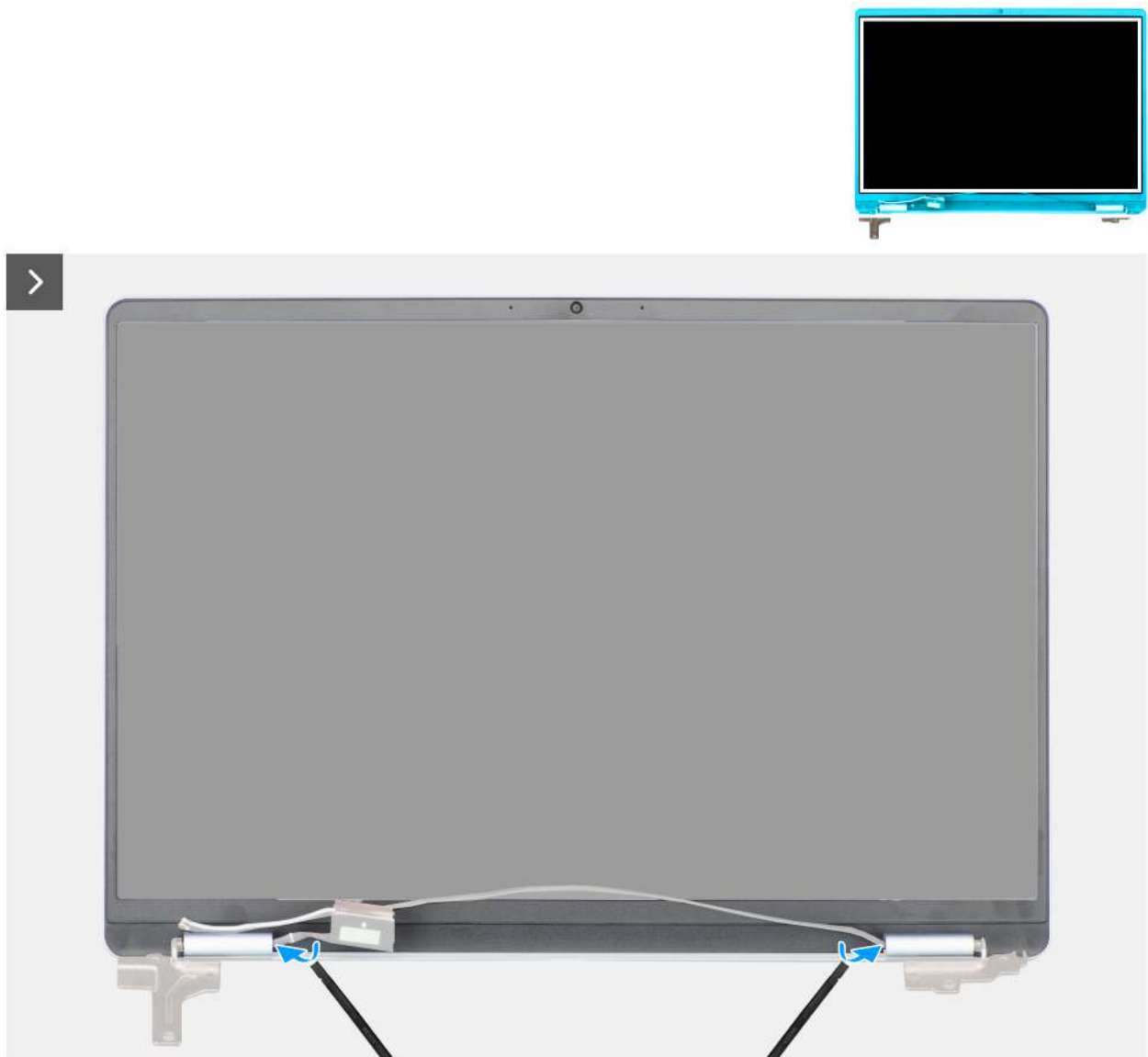

Figure 54. Removing the display bezel

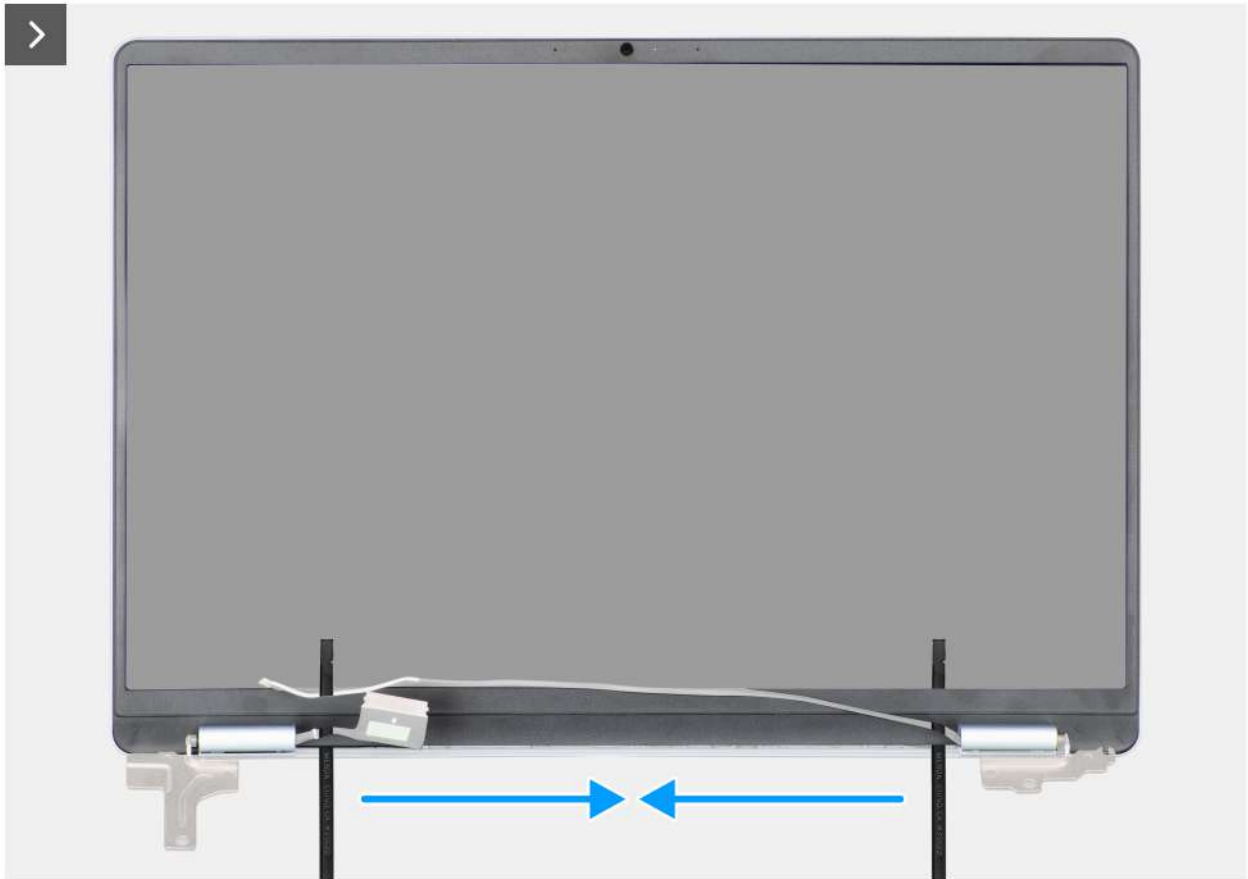

Figure 55. Removing the display bezel

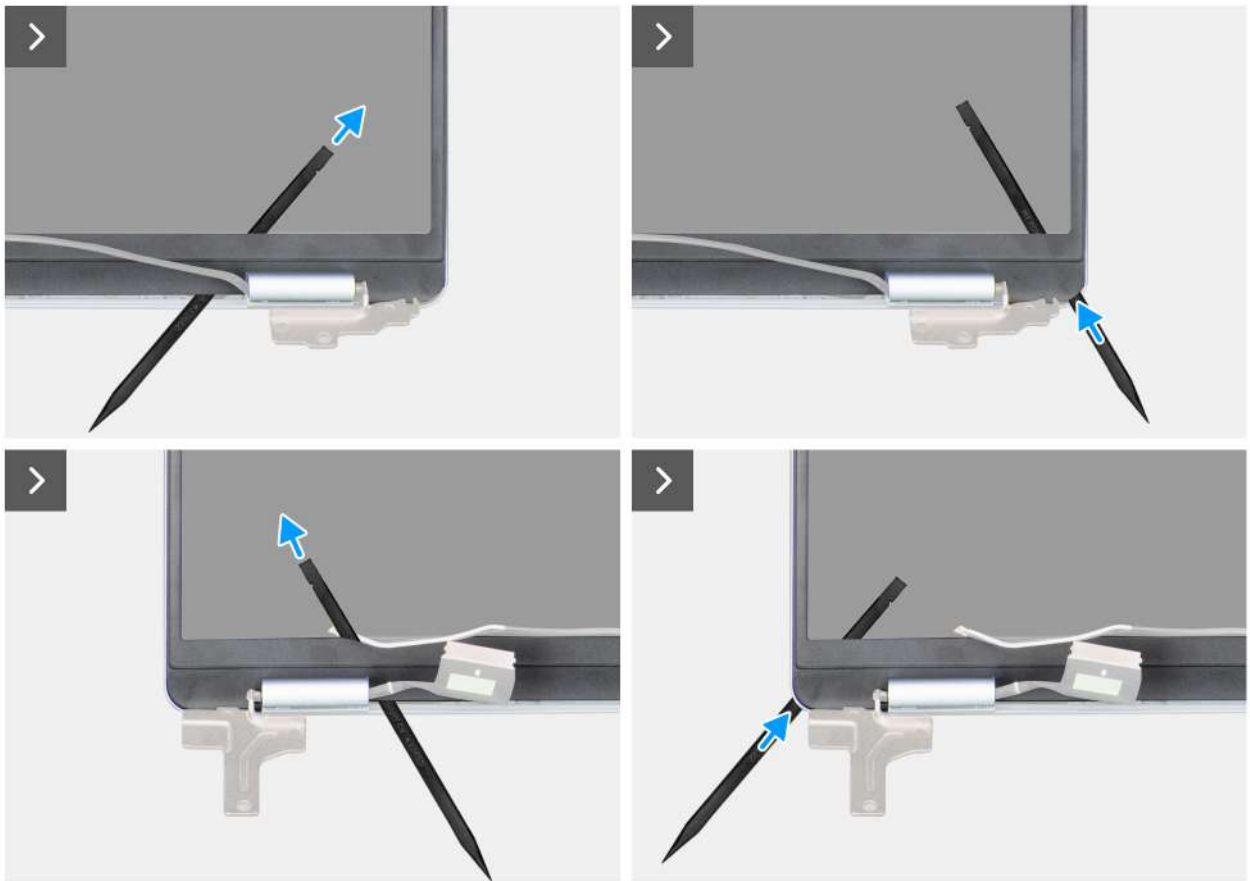

Figure 56. Removing the display bezel

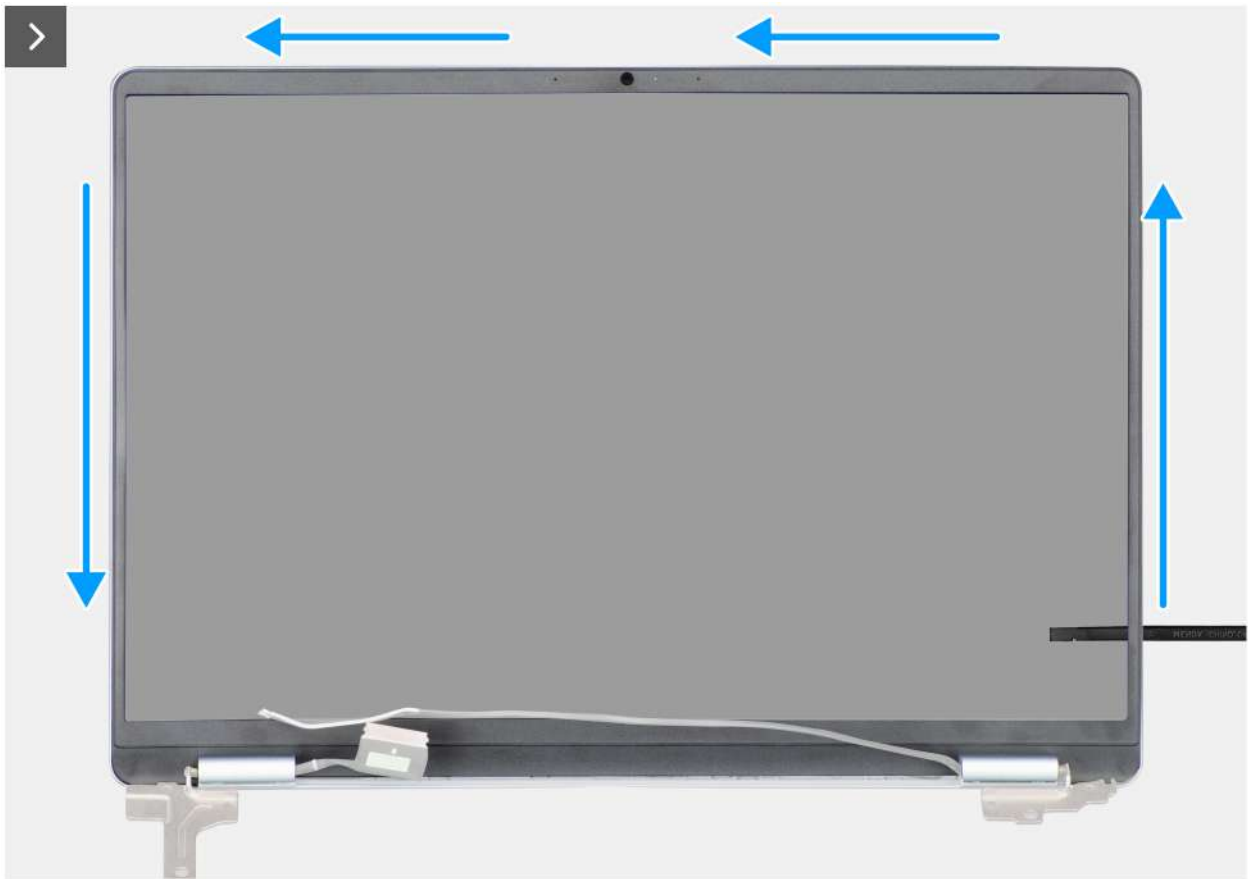

Figure 57. Removing the display bezel



Figure 58. Removing the display bezel

NOTE: The display bezel is a non-reusable component and must be replaced with a new bezel if it is removed from the computer.

Steps

1. Using a plastic scribe, pry open the display bezel from the outer edge of the openings at the bottom side of the display assembly, near the display hinges.
2. Carefully pry open the display bezel from the inner edge at the bottom-left and bottom-right corners of the display assembly.
3. Using the plastic scribe, pry open the outside edge of the left, right, and top sides of the display bezel.
4. Lift and remove the display bezel from the display assembly.

Installing the display bezel

CAUTION: The information in this section is intended for authorized service technicians only.

NOTE: The display-hinge caps are a part of the display bezel.

Prerequisites

If you are replacing a component, remove the existing component before performing the installation procedure.

About this task

The following images indicate the location of the display bezel and provide a visual representation of the installation procedure.



Figure 59. Installing the display bezel

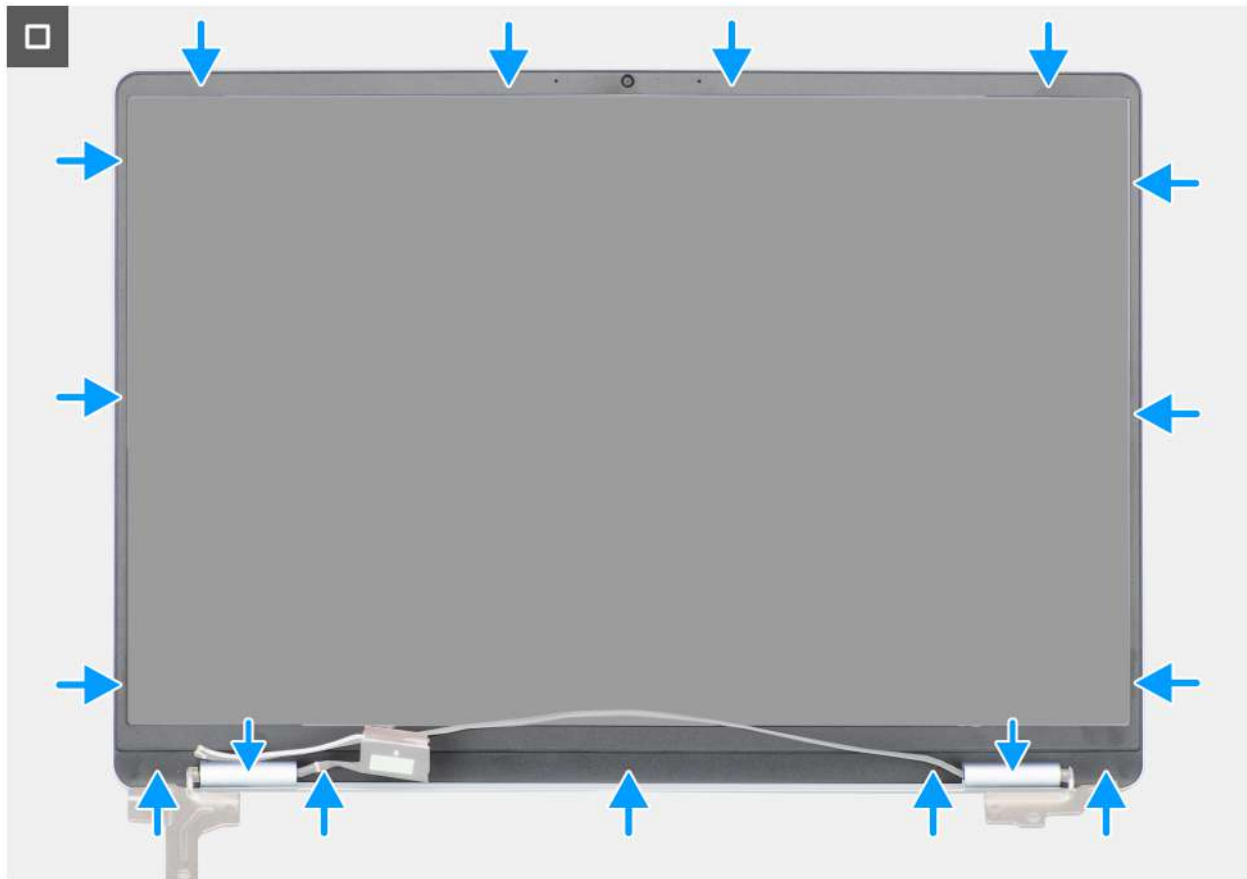

Figure 60. Installing the display bezel

Steps

1. Place the display assembly on a clean and flat surface.
2. Align and place the display bezel on the display assembly.
3. Starting from the top corner, press on the display bezel and work around the entire bezel until it snaps onto the display assembly.

Next steps

1. Install the [display assembly](#).
2. Install the [wireless card](#).
3. Install the [base cover](#).
4. Follow the procedure in [After working inside your computer](#).

Display panel

Removing the display panel

CAUTION: The information in this section is intended for authorized service technicians only.

NOTE: The display panel is assembled with the display brackets and display hinges as a single service part.

Prerequisites

1. Follow the procedure in [Before working inside your computer](#).
2. Remove the [base cover](#).

3. Remove the [wireless card](#).
4. Remove the [display assembly](#).
5. Remove the [display bezel](#).

About this task

The following images indicate the location of the display panel and provide a visual representation of the removal procedure.

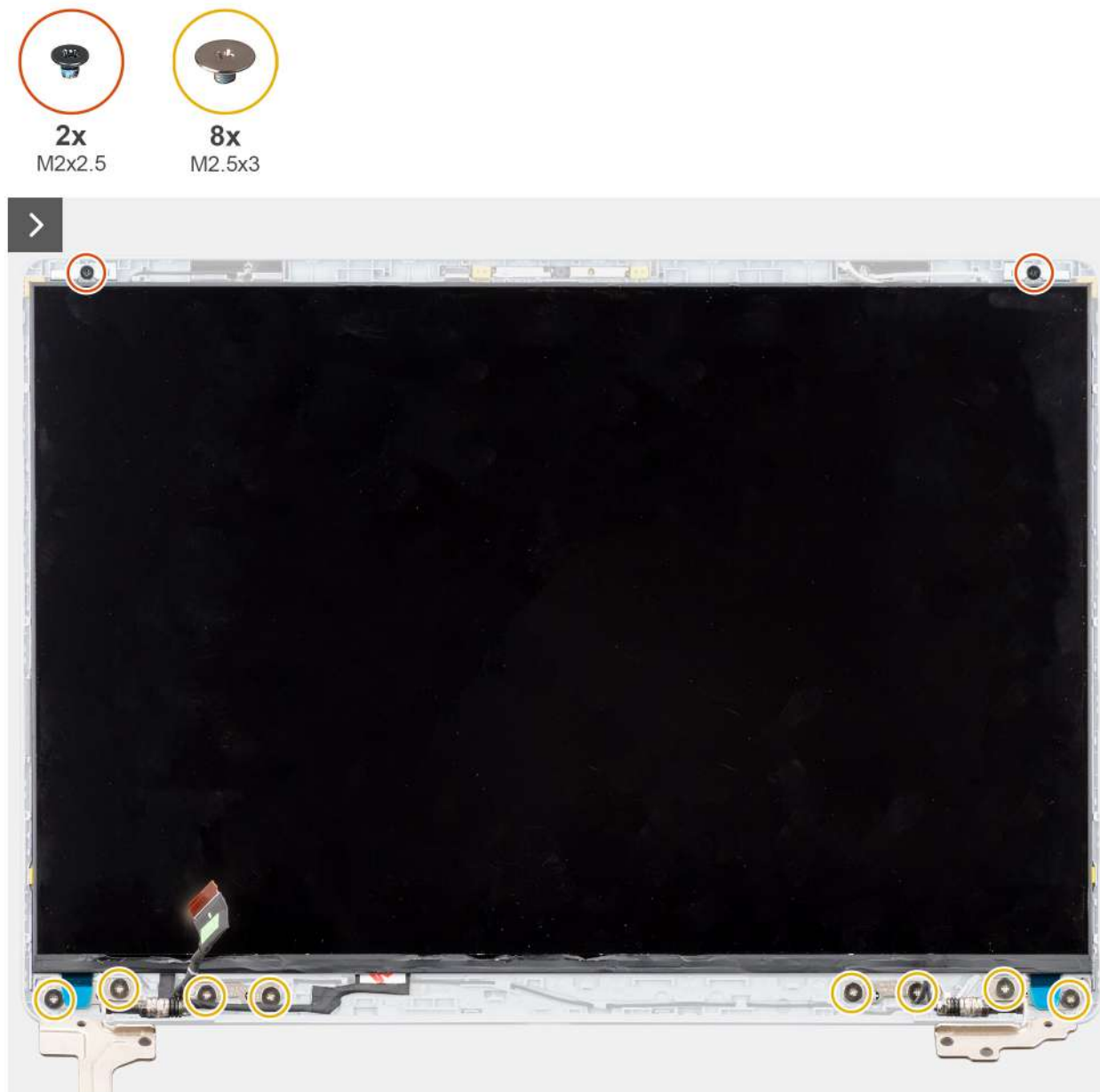

Figure 61. Removing the display panel

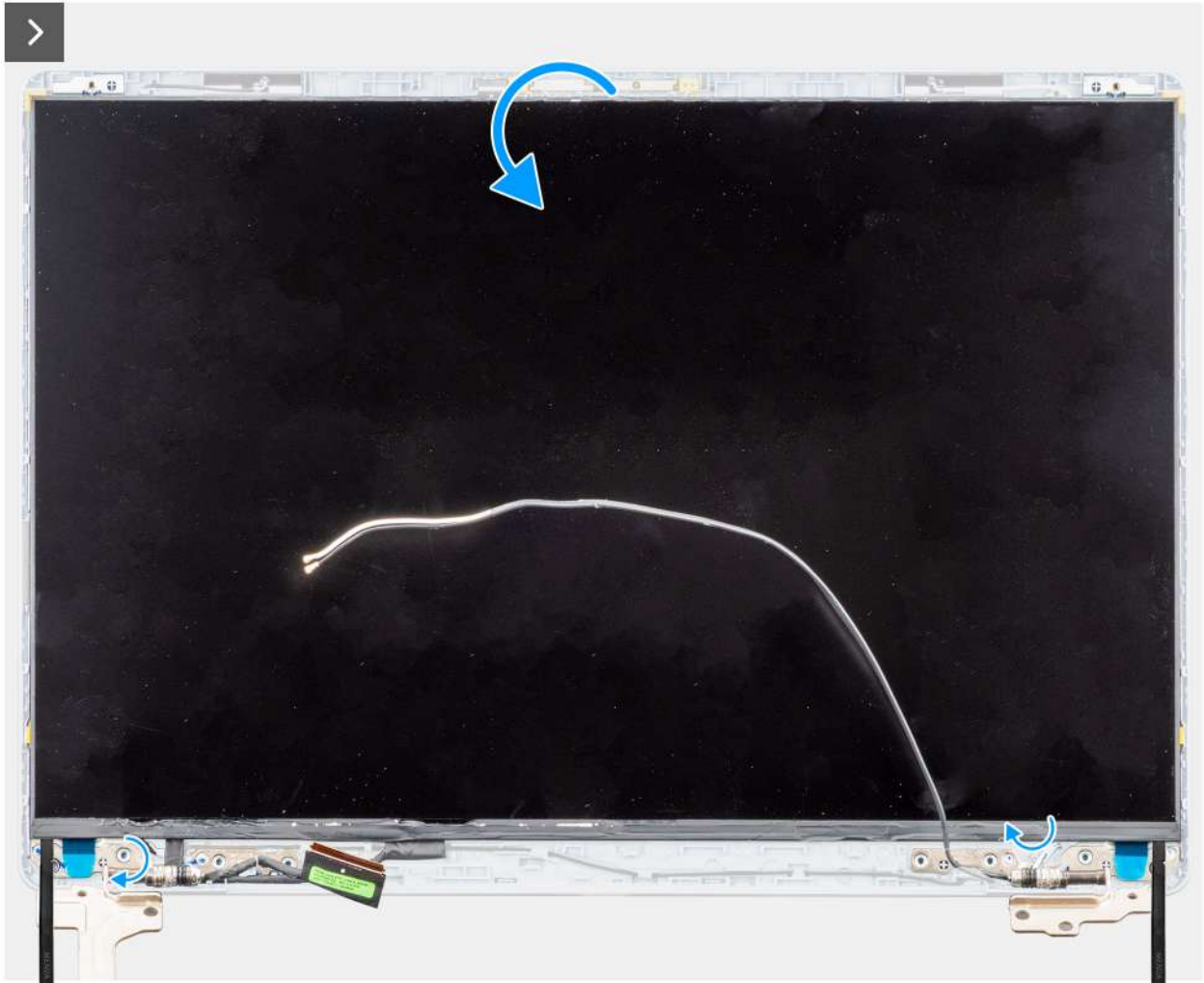

Figure 62. Removing the display panel

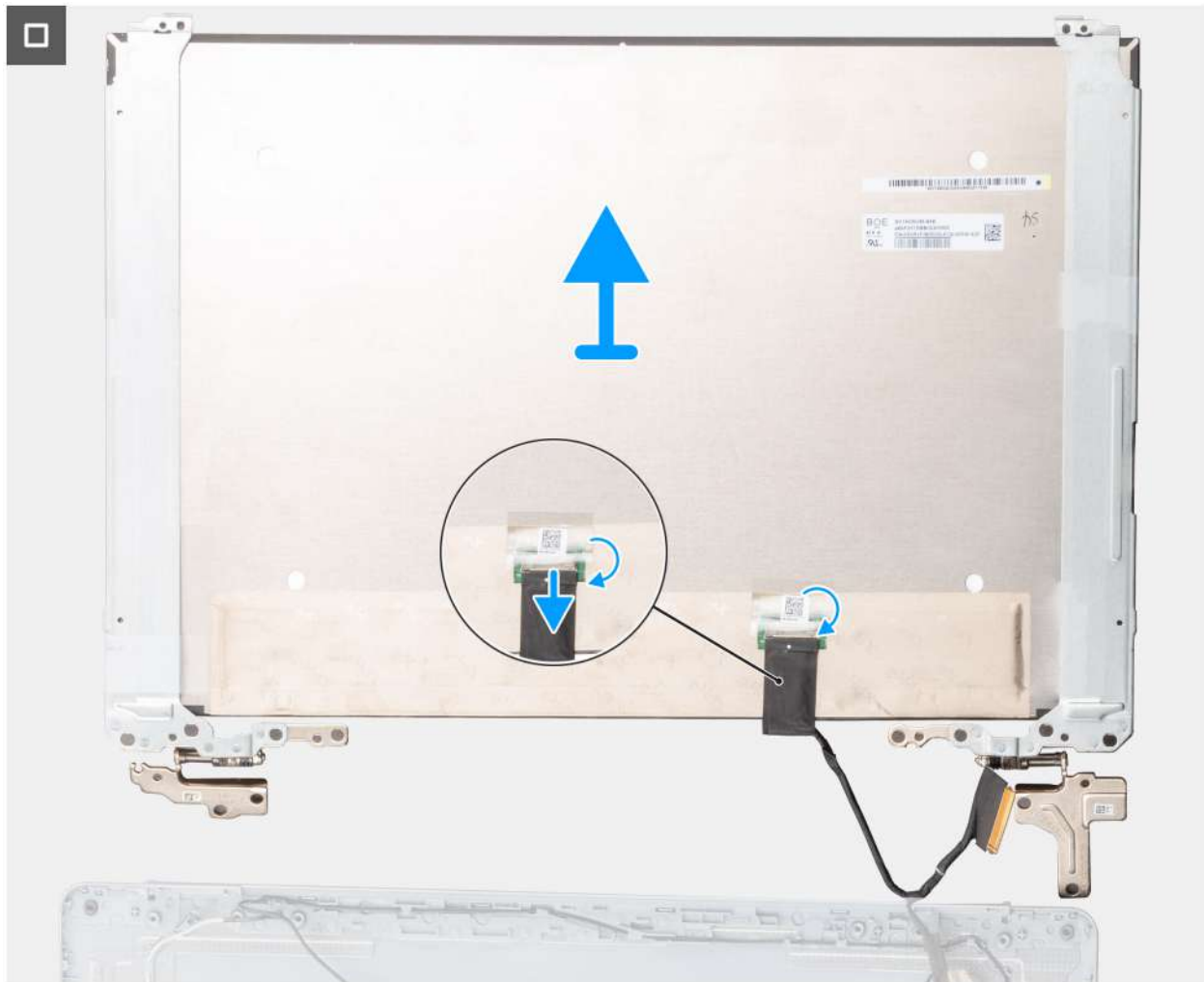

Figure 63. Removing the display panel

Steps

1. Remove the two screws (M2x2.5) and eight screws (M2.5x3) that secure the display panel to the display back-cover and antenna assembly.
2. Using a plastic scribe, pry the display panel from the bottom-right corner.
3. Using your hands, gently pry the display panel from the tabs along the right side of the display back-cover.
4. Repeat steps 2 and 3 to release the left side of the display panel.
5. Gently flip the display panel forward and peel back the Mylar tape that secures the display cable to the connector on the rear of the display panel.

NOTE: Ensure that the panel has a clean and smooth surface to rest on, to prevent damage.

6. Disconnect the display cable from the connector on the display panel.
7. Carefully unthread the display cable and wireless-antenna cable from the display hinges and remove the display panel.

CAUTION: The display panel is assembled with the display brackets and display hinges as a single-service part. Do not pull the two pieces of elastic tape and separate the brackets from the panel.

Installing the display panel

CAUTION: The information in this section is intended for authorized service technicians only.

NOTE: The display panel is assembled with the display brackets and display hinges as a single service part.

Prerequisites

If you are replacing a component, remove the existing component before performing the installation procedure.

About this task

The following images indicate the location of the display panel and provide a visual representation of the installation procedure.

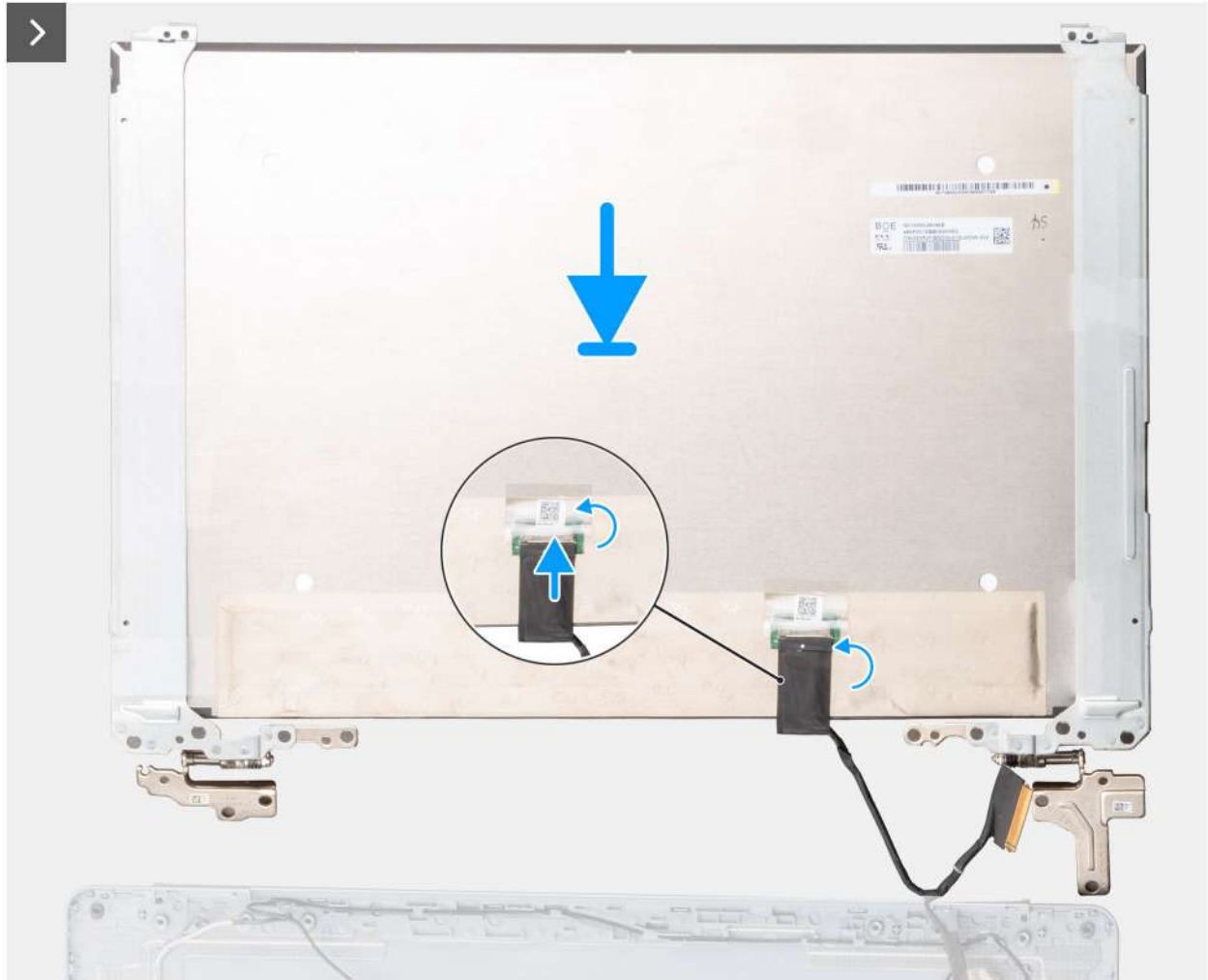

Figure 64. Installing the display panel

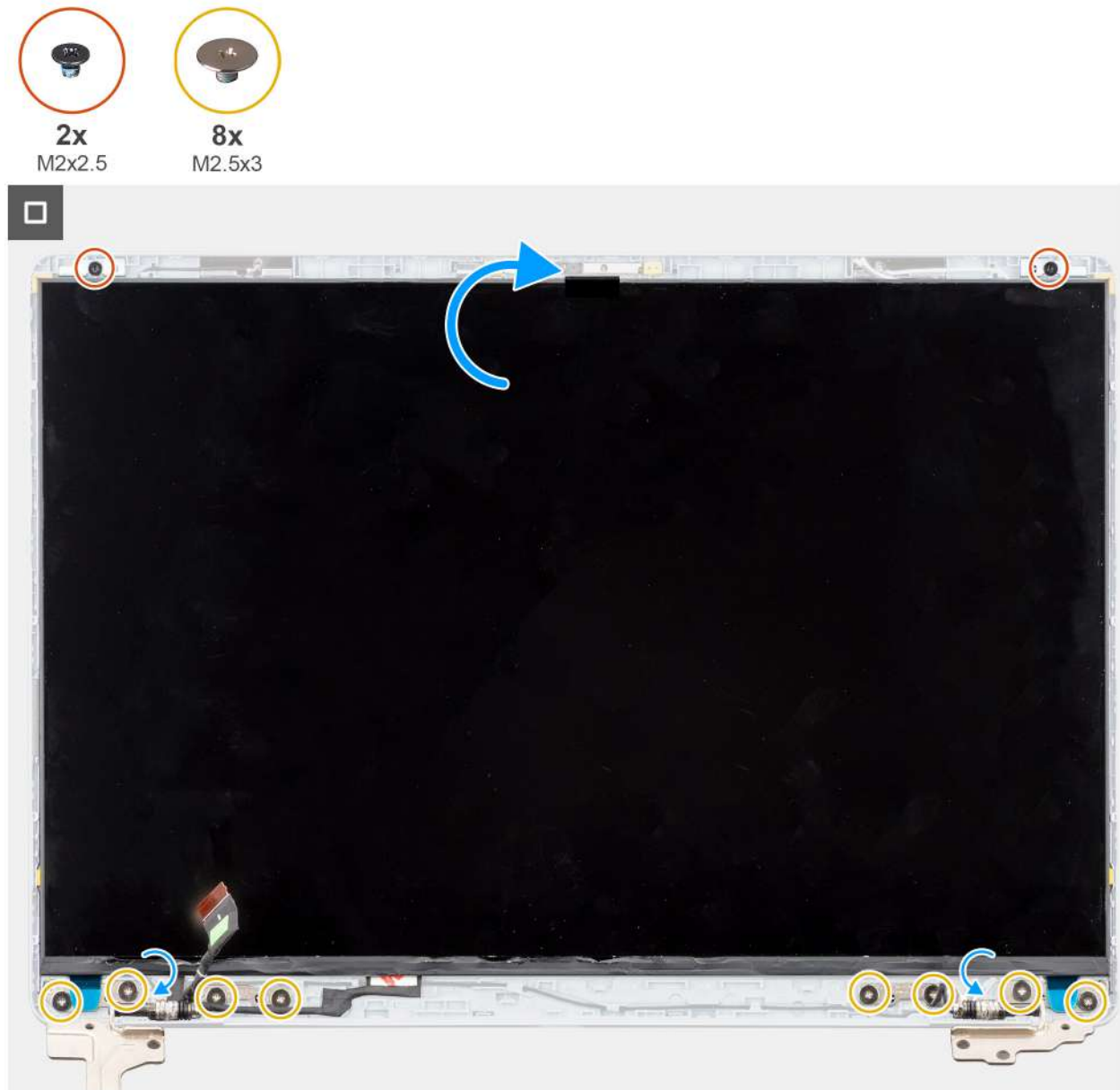

Figure 65. Installing the display panel

Steps

1. Place the display panel and display back-cover and antenna assembly on a clean and flat surface.
2. Carefully thread the display cable and wireless-antenna cables from the display hinges.
3. Connect the display cable to the connector on the display panel and close the latch.
4. Adhere the Mylar tape to secure the display cable to the connector on the display panel.
5. Gently flip the display panel and place the display panel on the display back-cover.
6. Gently push down on the edges of the display panel until it clicks into the tabs on the display back-cover.
7. Replace the two screws (M2x2.5) and eight screws (M2.5x3) to secure the display panel to the display back-cover and antenna assembly.

Next steps

1. Install the [display bezel](#).
2. Install the [display assembly](#).
3. Install the [wireless card](#).
4. Install the [base cover](#).

5. Follow the procedure in [After working inside your computer](#).

Display cable

Removing the display cable

 **CAUTION:** The information in this section is intended for authorized service technicians only.

Prerequisites

1. Follow the procedure in [Before working inside your computer](#).
2. Remove the [base cover](#).
3. Remove the [wireless card](#).
4. Remove the [display assembly](#).
5. Remove the [display bezel](#).
6. Remove the [display panel](#).

About this task

The following image indicates the location of the display cable and provides a visual representation of the removal procedure.

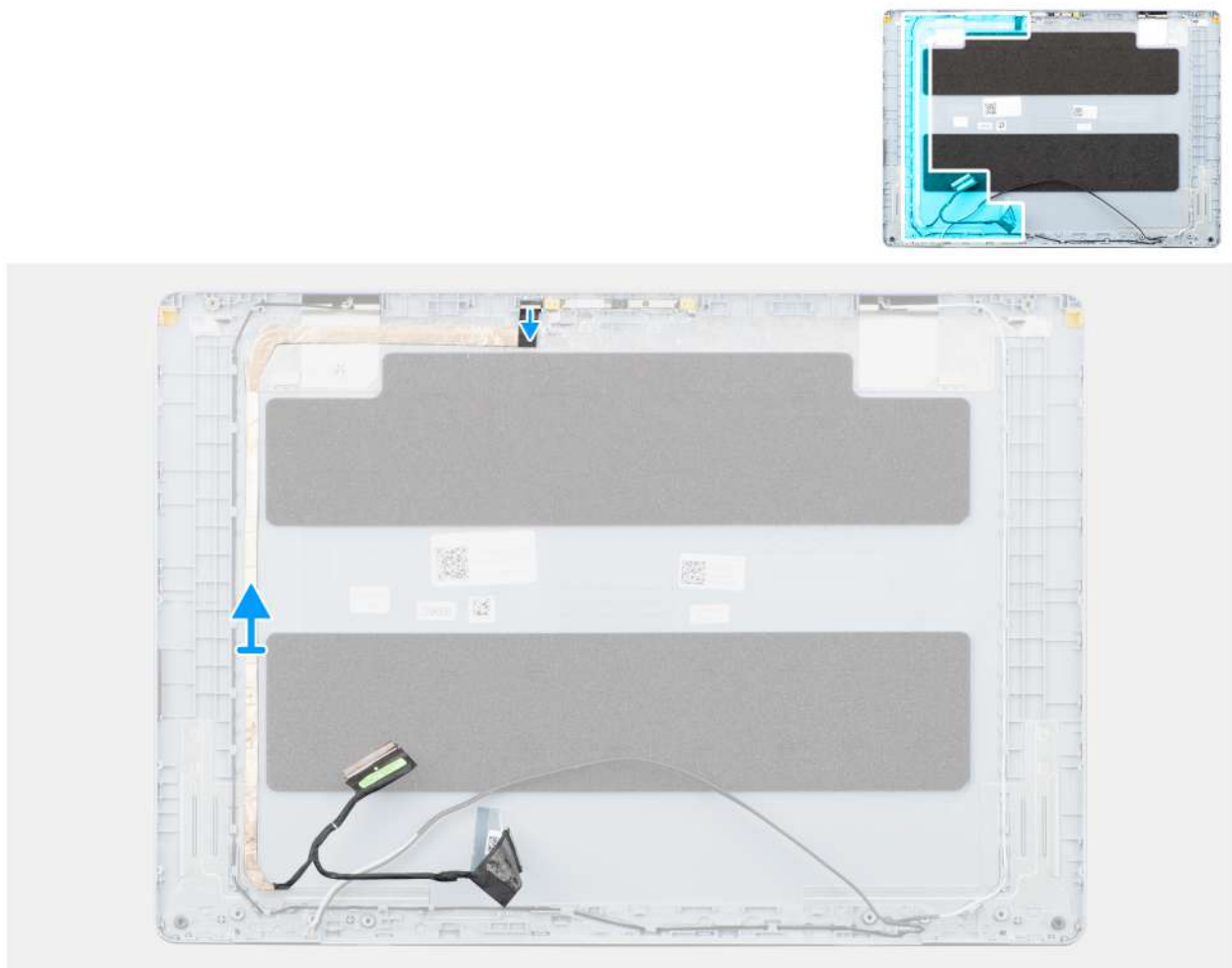

Figure 66. Removing the display cable

Steps

1. Disconnect the display cable from the connector on the camera.

- Carefully peel back and remove the display cable from the display back-cover.

Installing the display cable

CAUTION: The information in this section is intended for authorized service technicians only.

Prerequisites

If you are replacing a component, remove the existing component before performing the installation procedure.

About this task

The following image indicates the location of the display cable and provides a visual representation of the installation procedure.

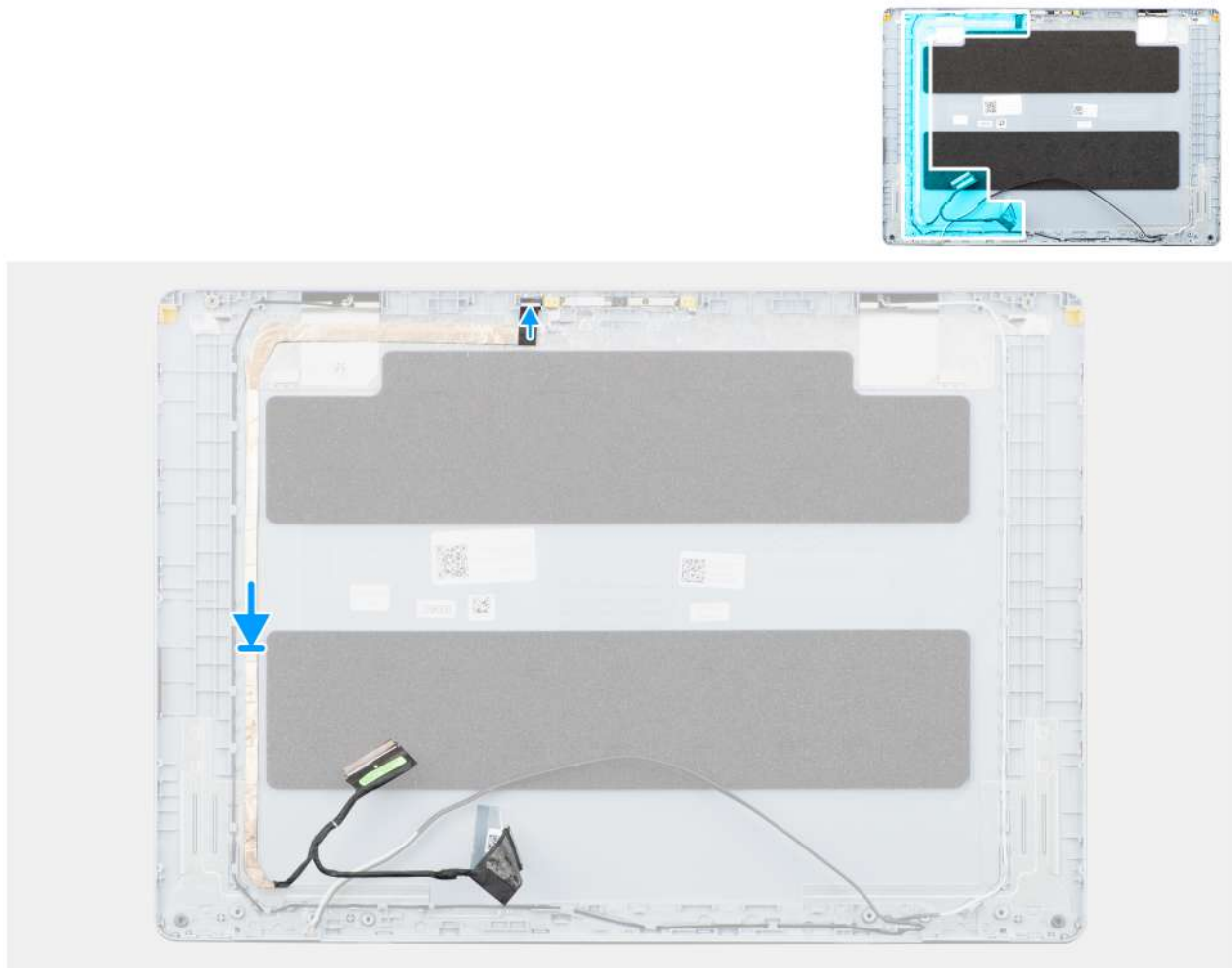

Figure 67. Installing the display cable

Steps

- Adhere the display cable to the display back-cover and antenna assembly.
- Connect the display cable to the connector on the camera.

Next steps

- Install the [display panel](#).
- Install the [display bezel](#).
- Install the [display assembly](#).
- Install the [wireless card](#).

5. Install the [base cover](#).
6. Follow the procedure in [After working inside your computer](#).

Camera

Removing the camera

⚠ CAUTION: The information in this section is intended for authorized service technicians only.

Prerequisites

1. Follow the procedure in [Before working inside your computer](#).
2. Remove the [base cover](#).
3. Remove the [wireless card](#).
4. Remove the [display assembly](#).
5. Remove the [display bezel](#).
6. Remove the [display panel](#).

About this task

The following image indicates the location of the camera and provides a visual representation of the removal procedure.

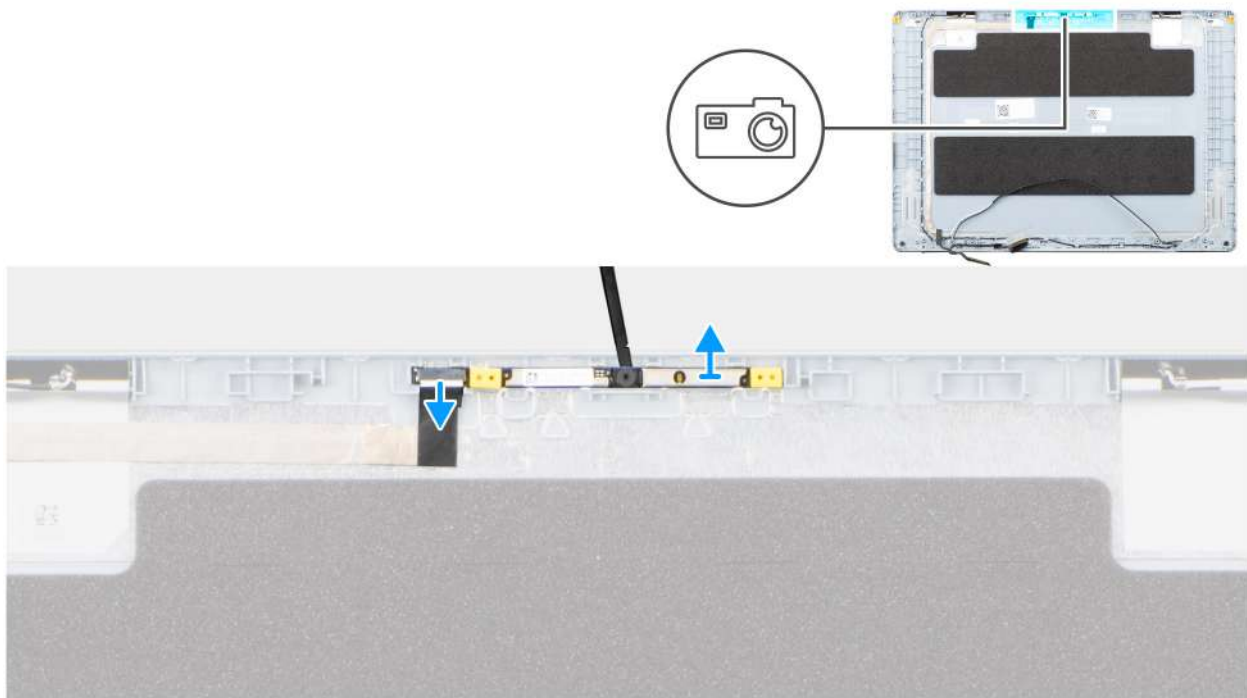

Figure 68. Removing the camera

Steps

1. Disconnect the display cable from the connector on the camera.
2. Using a plastic scribe, gently pry the camera from beneath off the display back-cover.
3. Remove the camera from the display back-cover.

Installing the camera

⚠ CAUTION: The information in this section is intended for authorized service technicians only.

Prerequisites

If you are replacing a component, remove the existing component before performing the installation procedure.

About this task

The following image indicates the location of the camera and provides a visual representation of the installation procedure.

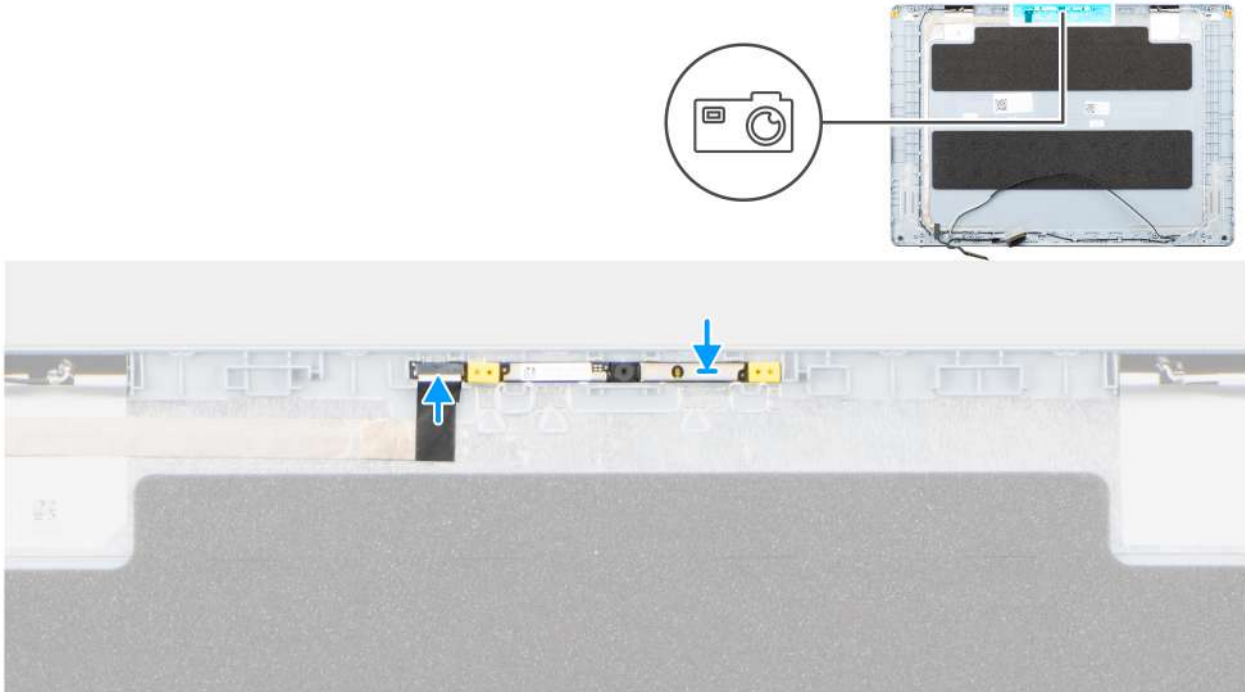

Figure 69. Installing the camera

Steps

1. Using the alignment post, adhere the camera on the display back-cover.
2. Connect the display cable to the connector on the camera.

Next steps

1. Install the [display panel](#).
2. Install the [display bezel](#).
3. Install the [display assembly](#).
4. Install the [wireless card](#).
5. Install the [base cover](#).
6. Follow the procedure in [After working inside your computer](#).

Display back-cover and antenna assembly

Removing the display back-cover and antenna assembly

⚠ CAUTION: The information in this section is intended for authorized service technicians only.

Prerequisites

1. Follow the procedure in [Before working inside your computer](#).
2. Remove the [base cover](#).
3. Remove the [wireless card](#).

4. Remove the [display assembly](#).
5. Remove the [display bezel](#).
6. Remove the [display panel](#).
7. Remove the [camera](#).
8. Remove the [display cable](#).

About this task

NOTE: The display back-cover and antenna assembly cannot be further disassembled once all the pre-removal parts procedures are completed. If the wireless antennas are malfunctioning and are required to be replaced, replace the entire display back-cover and antenna assembly.

The image below shows the display back-cover and antenna assembly after the **Prerequisites** have been performed for any display back-cover and antenna assembly replacement.

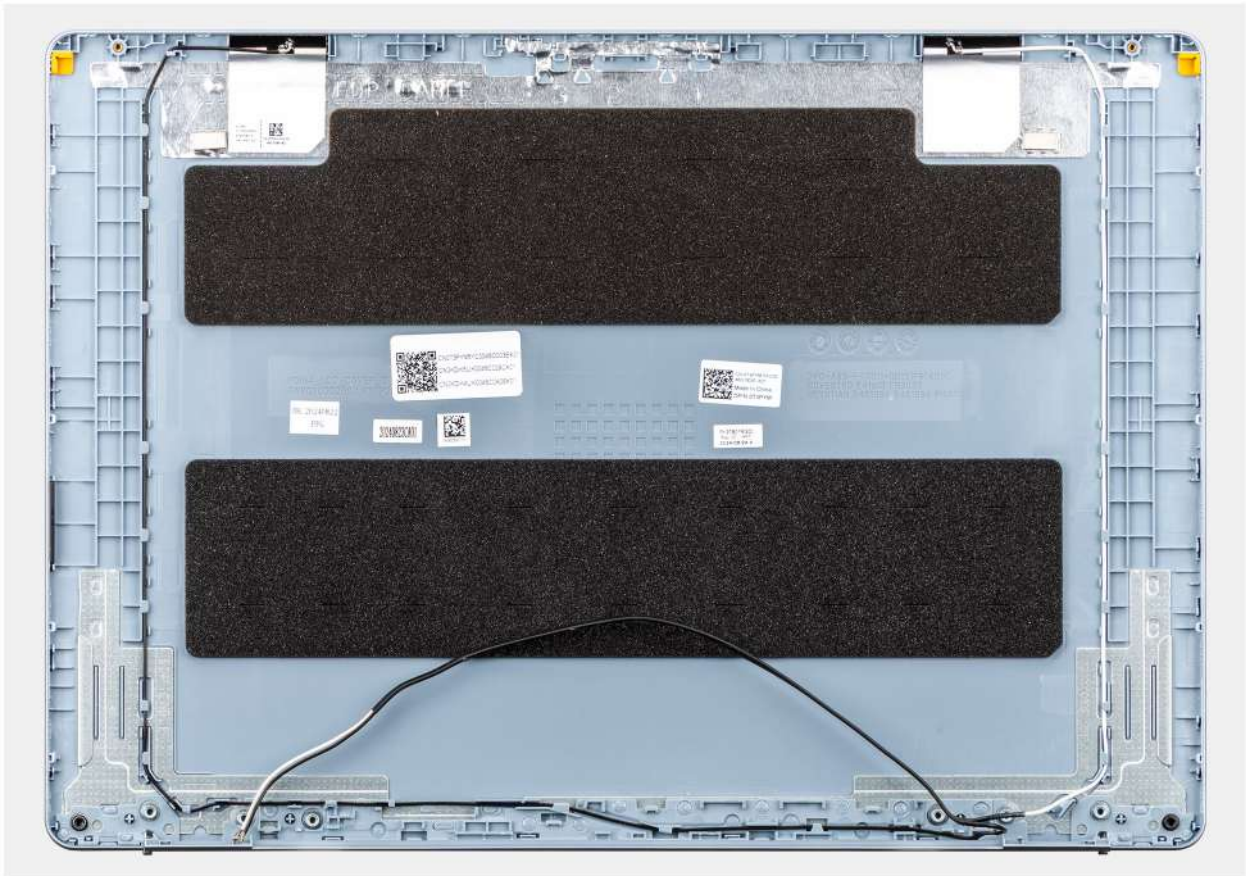

Figure 70. Display back-cover and antenna assembly

Steps

After performing the **Prerequisites**, you are left with the display back-cover and antenna assembly.

Installing the display back-cover and antenna assembly

CAUTION: The information in this section is intended for authorized service technicians only.

Prerequisites

If you are replacing a component, remove the existing component before performing the installation procedure.

About this task

The following image indicates the location of the display back-cover and antenna assembly and provides a visual representation of the installation procedure.

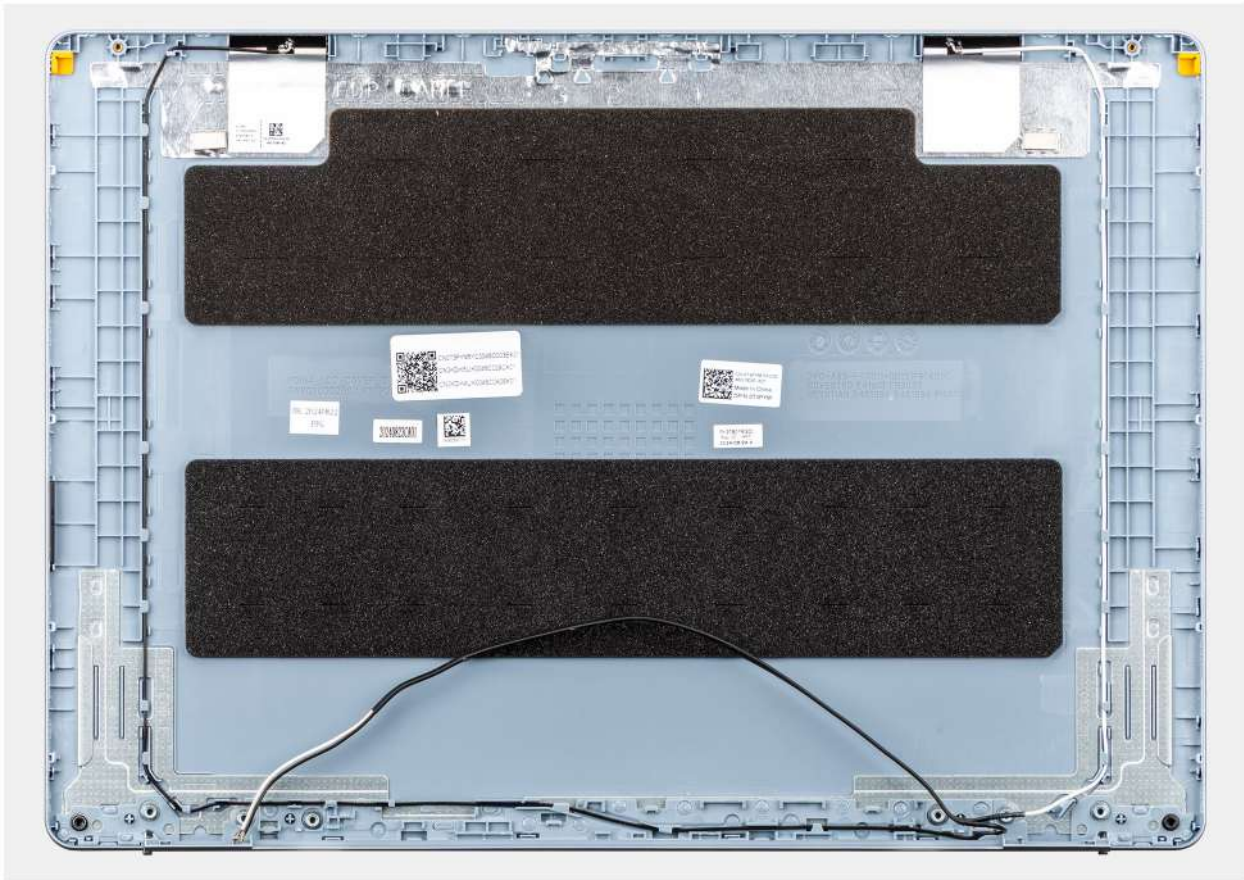

Figure 71. Display back-cover and antenna assembly

Steps

Place the display back-cover and antenna assembly on a flat surface and perform the **Next steps** to install the display back-cover and antenna assembly.

Next steps

1. Install the [display cable](#).
2. Install the [camera](#).
3. Install the [display panel](#).
4. Install the [display bezel](#).
5. Install the [display assembly](#).
6. Install the [wireless card](#).
7. Install the [base cover](#).
8. Follow the procedure in [After working inside your computer](#).

Power button

Removing the power button

CAUTION: The information in this section is intended for authorized service technicians only.

Prerequisites

1. Follow the procedure in [Before working inside your computer](#).
2. Remove the [base cover](#).
3. Remove the [I/O board](#).

About this task

The following image indicates the location of the power button and provides a visual representation of the removal procedure.



1x
M1.6x1.8

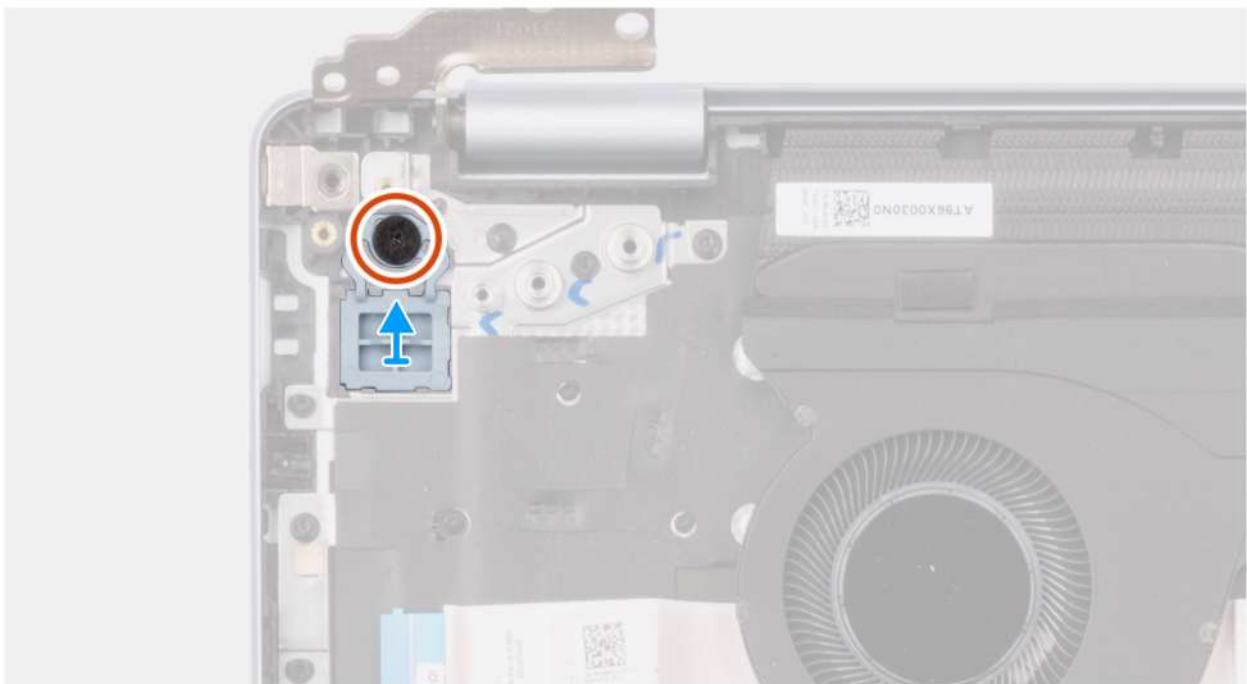

Figure 72. Removing the power button

Steps

1. Remove the screw (M1.6x1.8) that secures the power button to the palm-rest and keyboard assembly.
2. Lift the power button off the palm-rest and keyboard assembly.

Installing the power button

CAUTION: The information in this section is intended for authorized service technicians only.

Prerequisites

If you are replacing a component, remove the existing component before performing the installation procedure.

About this task

The following image indicates the location of the power button and provides a visual representation of the installation procedure.

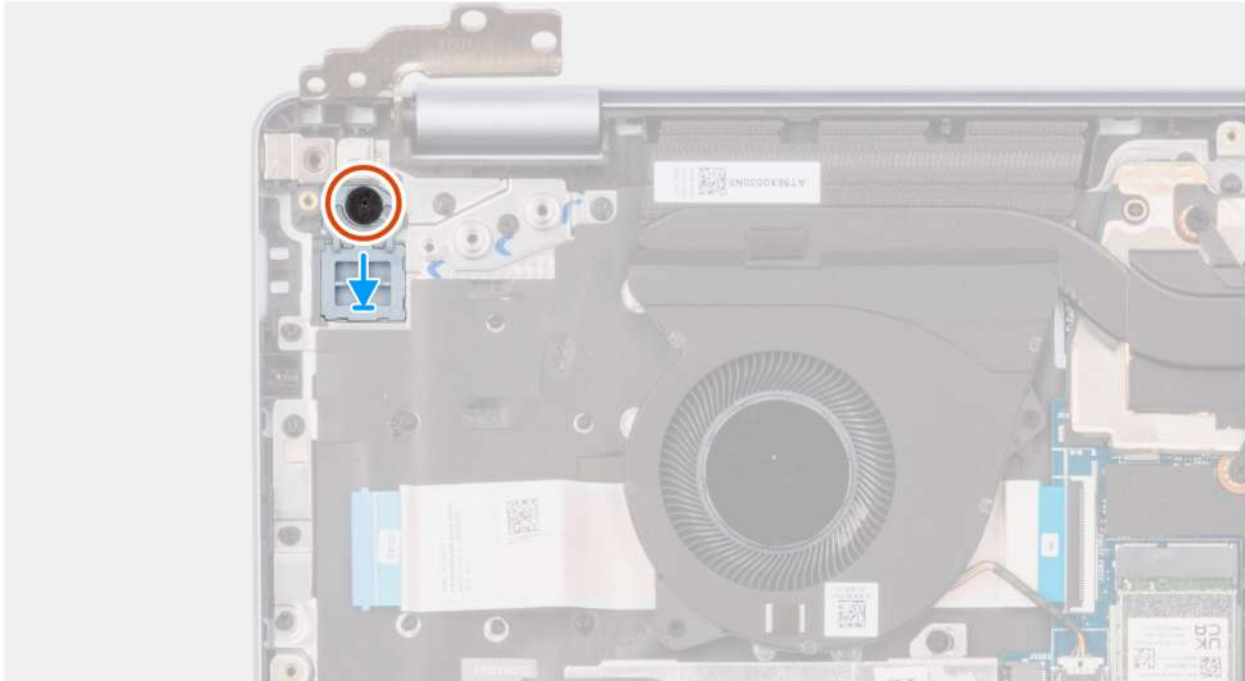

Figure 73. Installing the power button

Steps

1. Place the power button in the slot on the palm-rest and keyboard assembly.
2. Align the screw hole on the power button to the screw hole on the palm-rest and keyboard assembly.
3. Replace the screw (M1.6x1.8) to secure the power button to the palm-rest and keyboard assembly.

Next steps

1. Install the [I/O board](#).
2. Install the [base cover](#).
3. Follow the procedure in [After working inside your computer](#).

Power button with fingerprint reader

Removing the power button with fingerprint reader

 **CAUTION:** The information in this section is intended for authorized service technicians only.

Prerequisites

1. Follow the procedure in [Before working inside your computer](#).
2. Remove the [base cover](#).
3. Remove the [I/O board](#).

About this task

NOTE: This procedure applies only to computers shipped with a power button with fingerprint reader installed.

The following images indicate the location of the power button with fingerprint reader and provide a visual representation of the removal procedure.

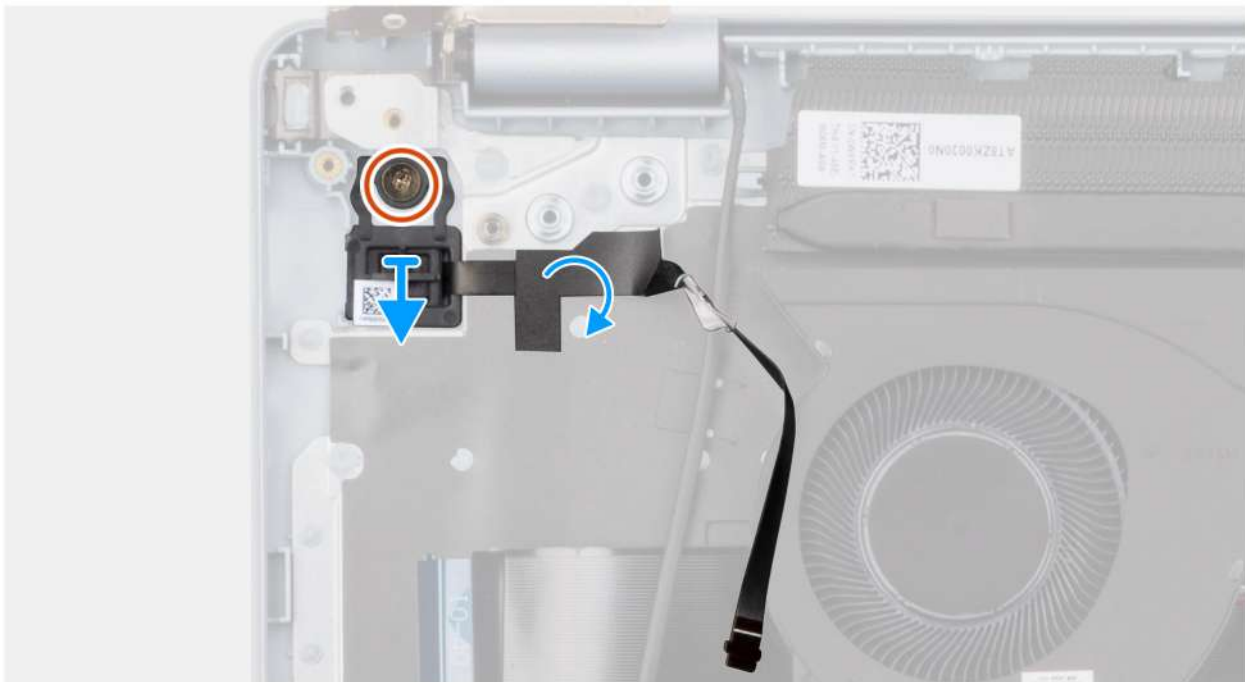

Figure 74. Removing the power button with fingerprint reader

Steps

1. Peel back the keyboard Mylar that covers the fingerprint-reader cable.
2. Peel back the fingerprint-reader cable from the palm-rest and keyboard assembly.
3. Remove the screw (M1.6x1.8) that secures the power button to the palm-rest and keyboard assembly.
4. Lift the power button, along with fingerprint-reader cable, off the slot on the palm-rest and keyboard assembly.

Installing the power button with fingerprint reader

CAUTION: The information in this section is intended for authorized service technicians only.

Prerequisites

If you are replacing a component, remove the existing component before performing the installation procedure.

About this task

NOTE: This procedure applies only to computers shipped with a power button with fingerprint reader installed.

The following image indicates the location of the power button with fingerprint reader and provides a visual representation of the installation procedure.



1x
M1.6x1.8

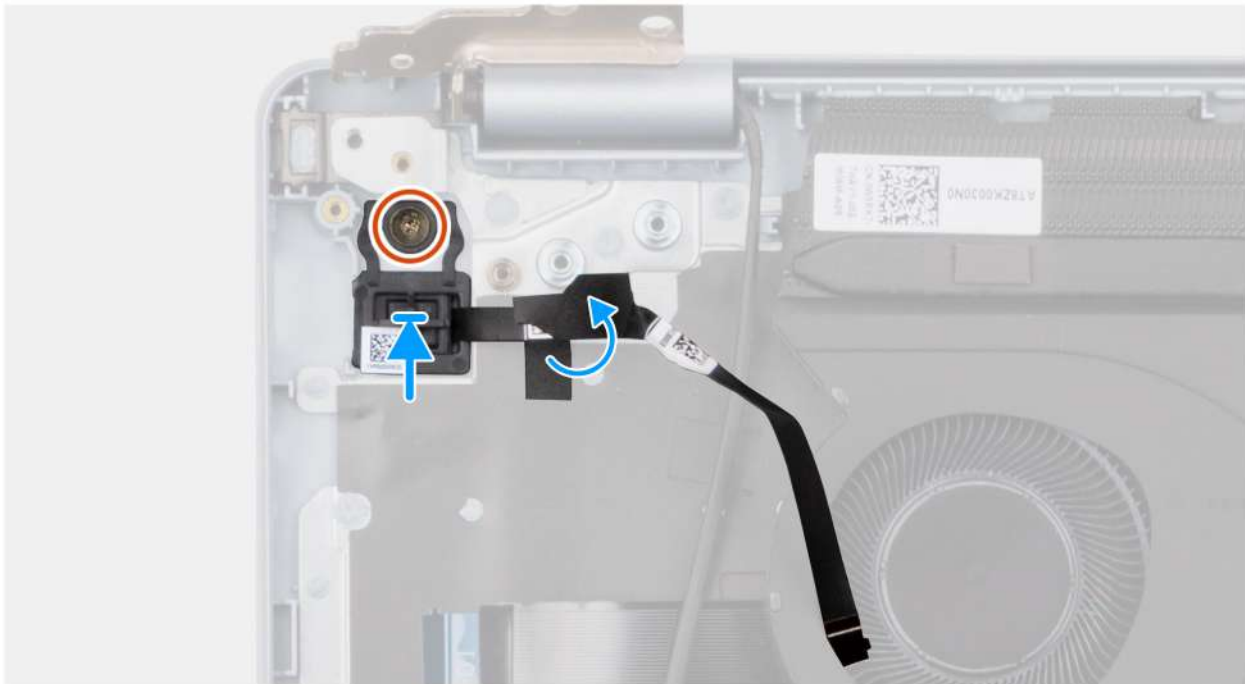

Figure 75. Installing the power button with fingerprint reader

Steps

1. Place the power button, along with fingerprint-reader cable, in the slot on the palm-rest and keyboard assembly.
2. Align the screw hole on the power button to the screw hole on the palm-rest and keyboard assembly.
3. Replace the screw (M1.6x1.8) to secure the power button to the palm-rest and keyboard assembly.
4. Adhere the fingerprint-reader cable to the palm-rest and keyboard assembly.

NOTE: Ensure that the grounding tape on the top side of the fingerprint-reader cable is adhered to the keyboard plate.

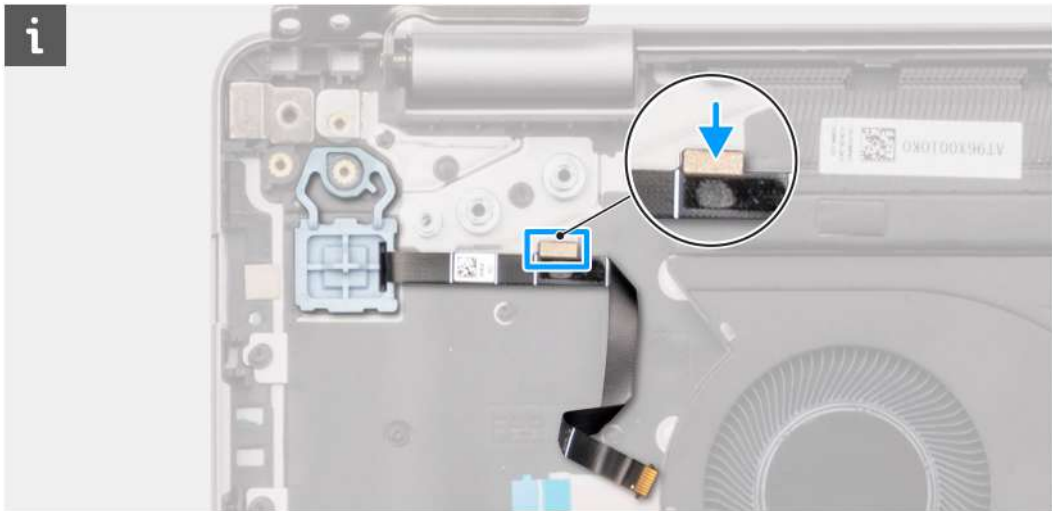

Figure 76. Adhering the finger-print cable to palm-rest and keyboard assembly

5. Adhere the keyboard Mylar to cover the fingerprint-reader cable.

Next steps

1. Install the [I/O board](#).
2. Install the [base cover](#).
3. Follow the procedure in [After working inside your computer](#).

Power-adapter port

Removing the power-adapter port

CAUTION: The information in this section is intended for authorized service technicians only.

Prerequisites

1. Follow the procedure in [Before working inside your computer](#).
2. Remove the [base cover](#).

About this task

The following images indicate the location of the power-adapter port and provide a visual representation of the removal procedure.



2x
M2.5x5

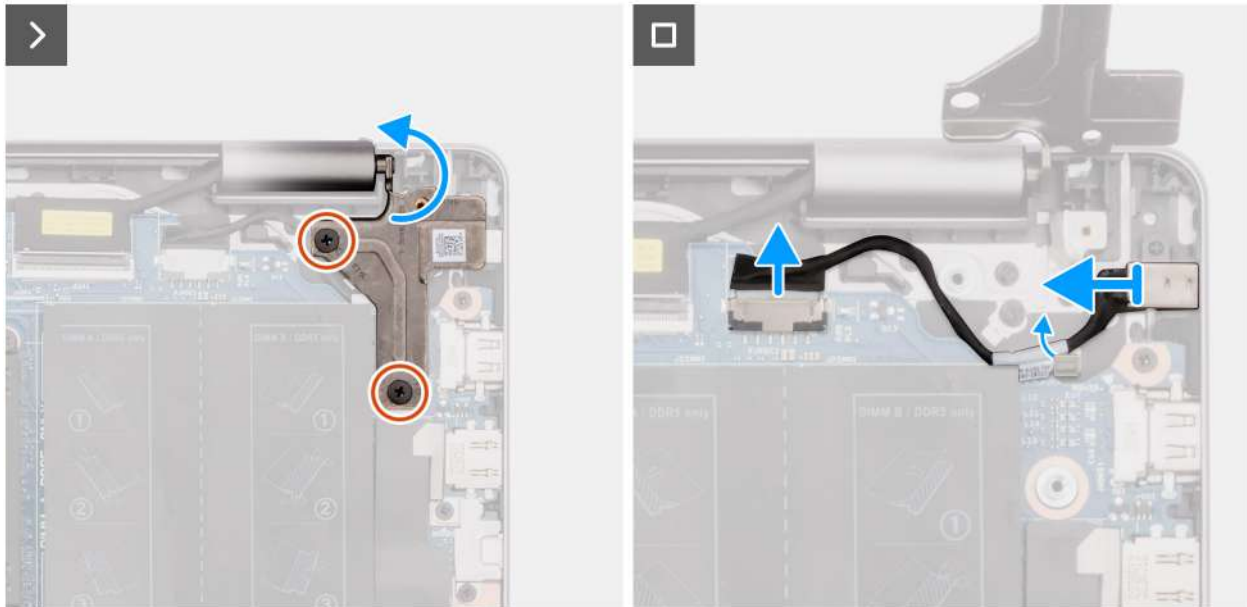

Figure 77. Removing the power-adapter port

Steps

1. Remove the two screws (M2.5x5) that secure the left-display hinge to the system board and the palm-rest and keyboard assembly.
2. Using a plastic scribe, lift the left-display hinge to an angle of 90 degrees from the palm-rest and keyboard assembly to access the power-adapter port.
3. Disconnect the power-adapter port cable from the connector (DCIN) on the system board.
4. Remove the power-adapter port cable from the routing guide on the palm-rest and keyboard assembly.
5. Remove the power-adapter port from the slot on the palm-rest and keyboard assembly.

Installing the power-adapter port

CAUTION: The information in this section is intended for authorized service technicians only.

Prerequisites

If you are replacing a component, remove the existing component before performing the installation procedure.

About this task

The following images indicate the location of the power-adapter port and provide a visual representation of the installation procedure.



2x
M2.5x5

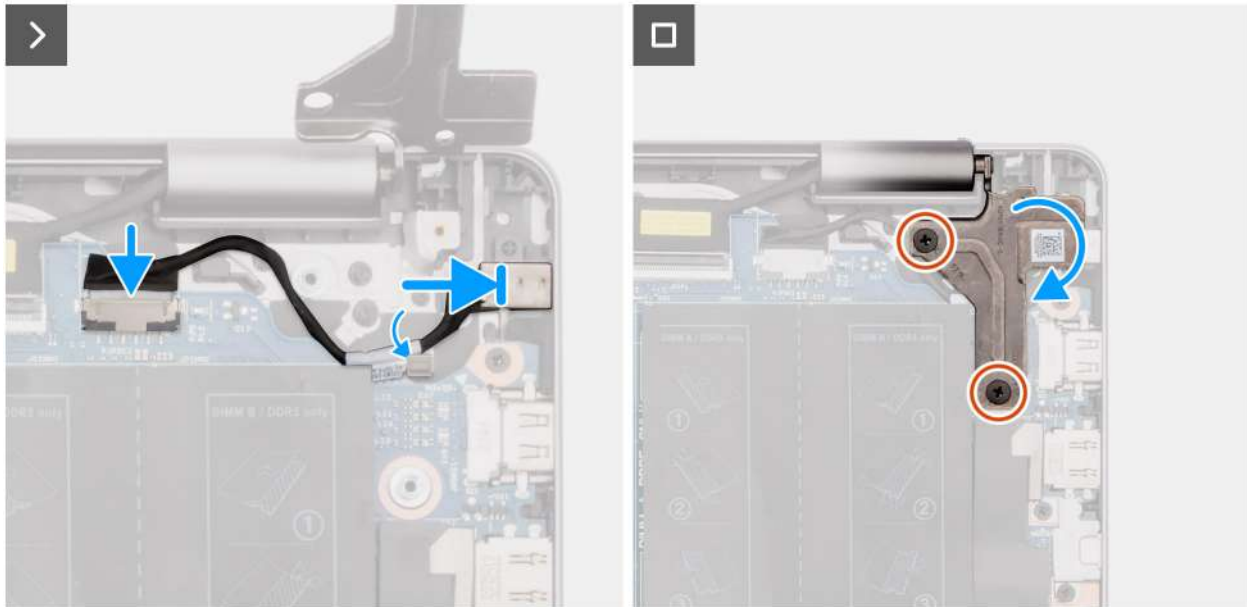

Figure 78. Installing the power-adapter port

Steps

1. Align and place the power-adapter port in the slot on the palm-rest and keyboard assembly.
2. Route the power-adapter port cable through the guide on the palm-rest and keyboard assembly.
3. Connect the power-adapter port cable to the connector (DCIN) on the system board.
4. Close the left-display hinge to align the screw holes on the left-display hinge to the screw holes on the system board and the palm-rest and keyboard assembly.
5. Replace the two screws (M2.5x5) to secure the left-display hinge to the system board and the palm-rest and keyboard assembly.

Next steps

1. Install the [base cover](#).
2. Follow the procedure in [After working inside your computer](#).

System board

Removing the system board

CAUTION: The information in this section is intended for authorized service technicians only.

Prerequisites

1. Follow the procedure in [Before working inside your computer](#).
2. Remove the [base cover](#).
3. Remove the [memory module](#).

4. Remove the [solid state drive](#).
5. Remove the [wireless card](#).
6. Remove the [heat sink - for computers shipped with integrated graphics card](#) or [heat sink - for computers shipped with discrete graphics card](#), whichever is applicable.

i NOTE: When removing the system board to replace or access other parts, the system board can be removed with the heat sink attached to it in order to simplify the procedure and preserve the thermal bond between the system board and heat sink.

About this task

The following image indicates the connectors on your system board.

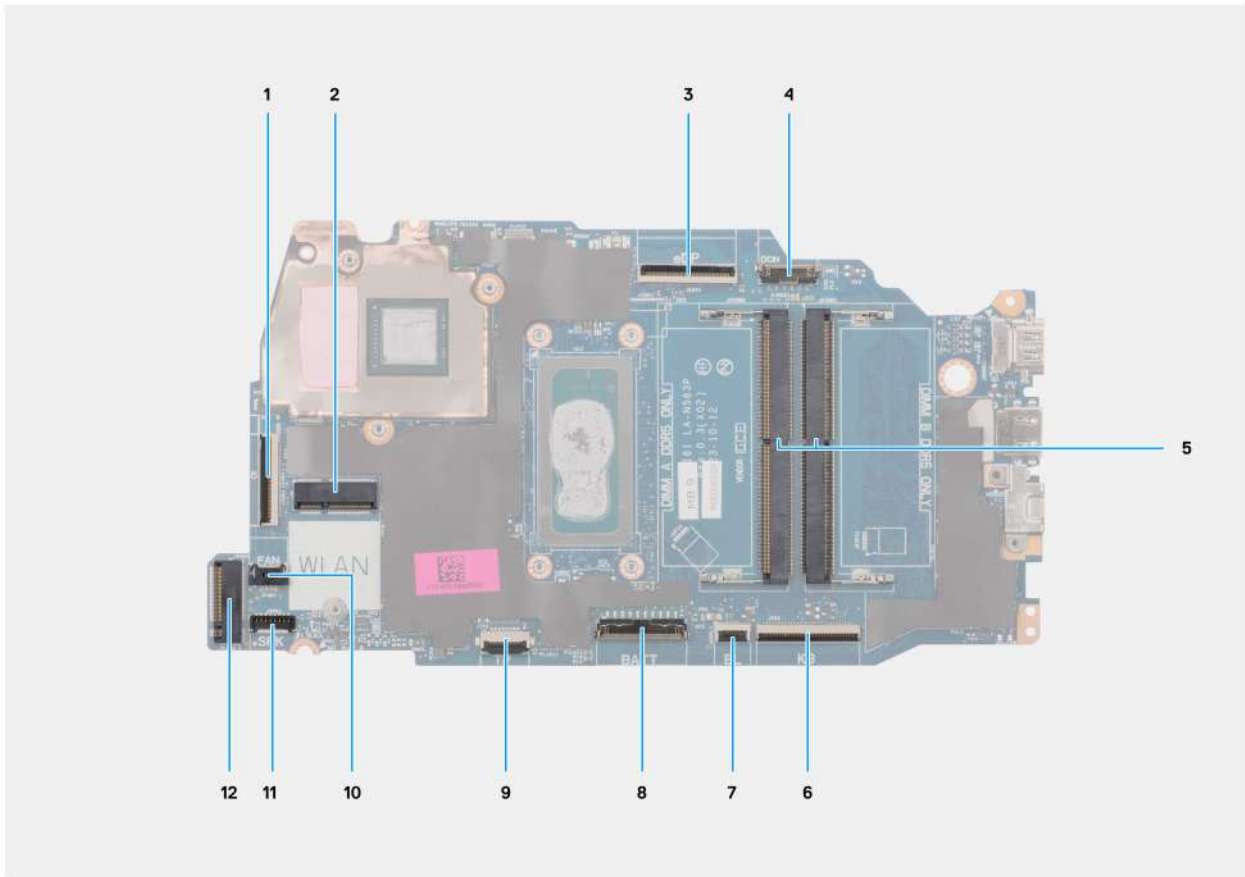

Figure 79. System board connectors

1. I/O-board cable (IO) connector
2. Wireless card (WLAN) connector
3. Display cable (eDP) connector
4. Power-adaptor port (DCIN) connector
5. Memory module x2 (DIMM A DDR5 ONLY + DIMM B DDR5 ONLY) connectors
6. Keyboard cable (KB) connector
7. Keyboard-backlight cable (BL) connector
8. Battery cable (BATT) connector
9. Touchpad cable (TP) connector
10. Fan cable (FAN) connector
11. Speaker cable (SPK) connector
12. Solid state drive (SSD) connector

The following images indicate the location of the system board and provide a visual representation of the removal procedure.

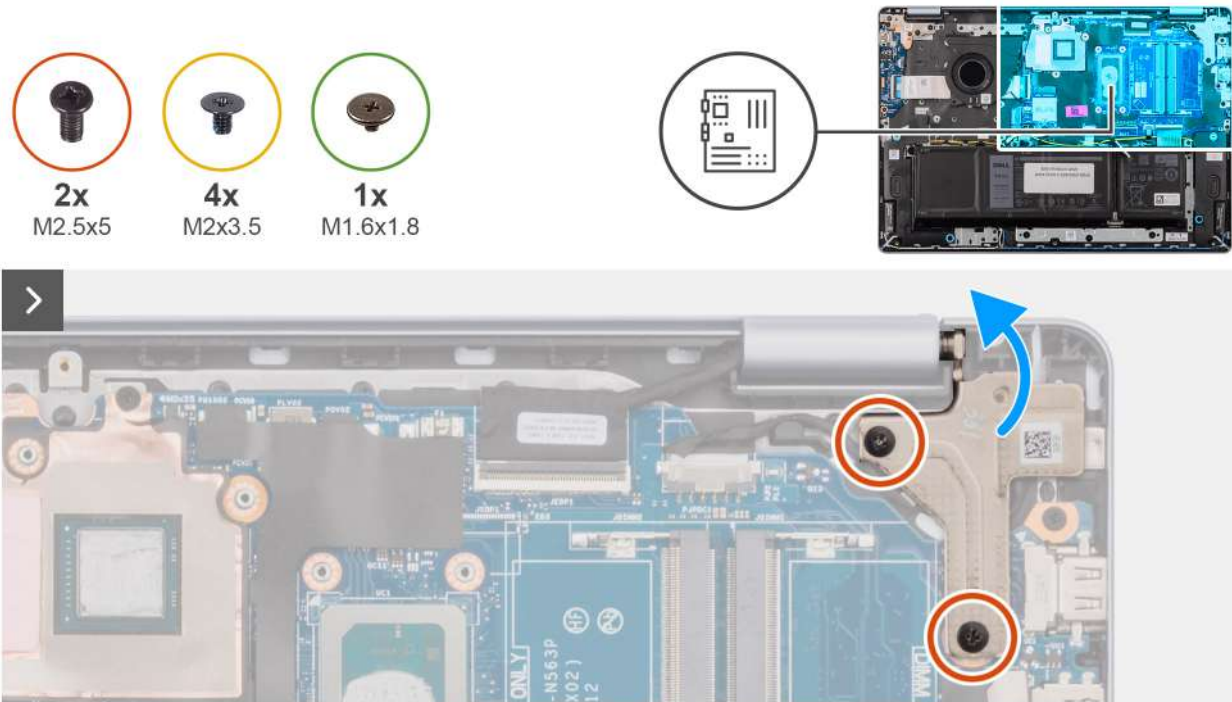

Figure 80. Removing the system board

Steps

1. Remove the two screws (M2.5x5) that secure the left-display hinge to the palm-rest and keyboard assembly.
2. Using a plastic scribe, lift the left-display hinge to an angle of 90 degrees from the palm-rest and keyboard assembly.
3. Disconnect the following cables on the system board:
 - a. display cable (eDP)
 - b. power-adapter port cable (DCIN)
 - c. keyboard cable (KB)
 - d. keyboard-backlight cable (BL)
 - e. battery cable (BATT)
 - f. touchpad cable (TP)
 - g. speaker cable (SPK)
 - h. fan cable (FAN)
 - i. I/O-board cable (IO)

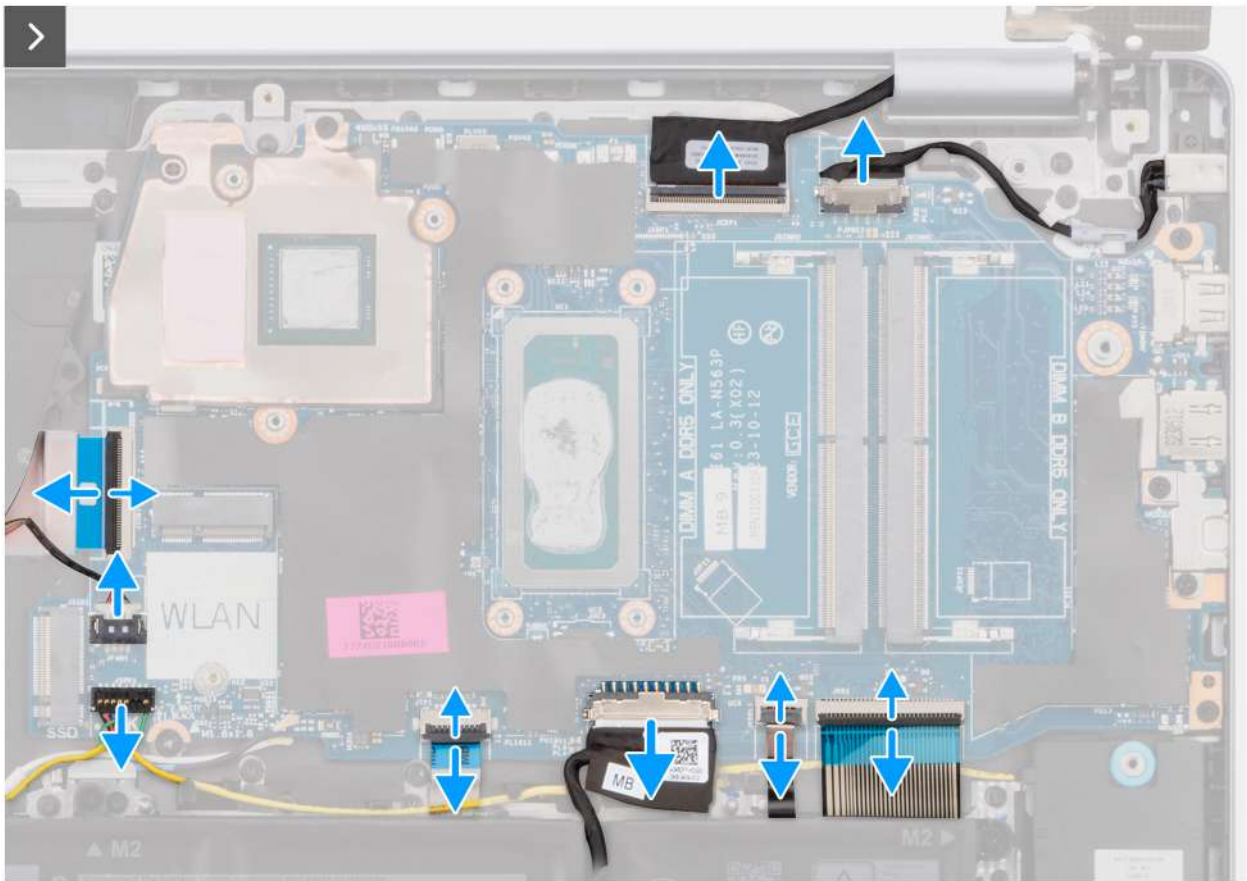

Figure 81. Removing the system board

4. Remove the screw (M1.6x1.8) and the four screws (M2x3.5) that secure the system board to the palm-rest and keyboard assembly.

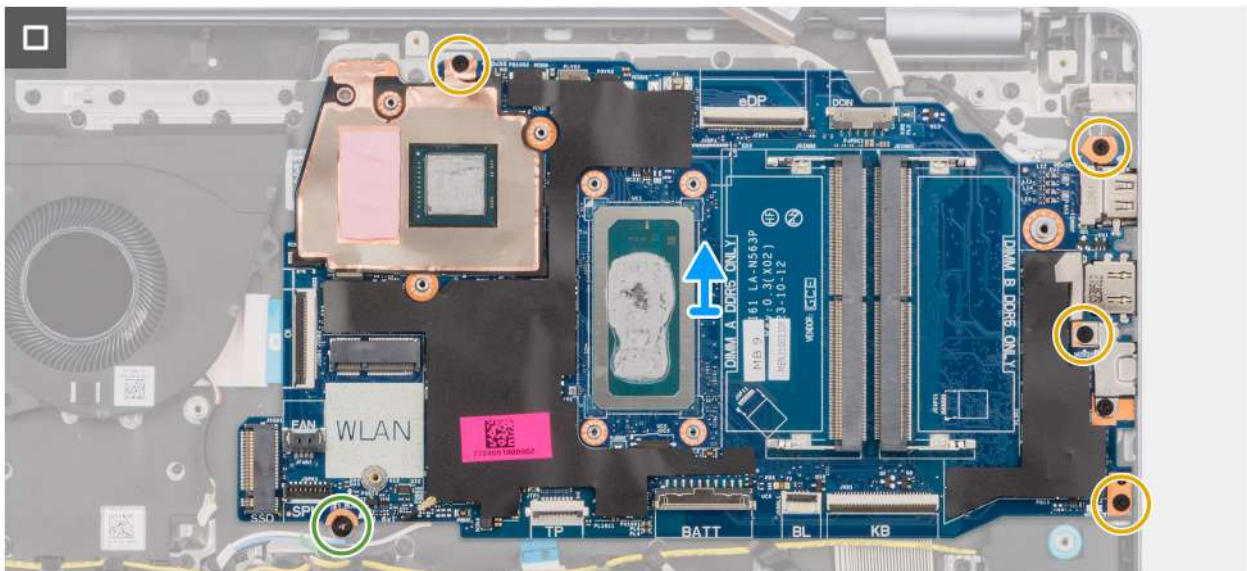

Figure 82. Removing the system board

NOTE: The USB Type-C bracket is secured to the system board with a single screw (M2x3.5). The bracket is attached with the system board as a service part and must not be removed from the system board.



Figure 83. System board - USB Type-C bracket

5. Carefully lift and remove the system board from the palm-rest and keyboard assembly.

Installing the system board

CAUTION: The information in this section is intended for authorized service technicians only.

Prerequisites

If you are replacing a component, remove the existing component before performing the installation procedure.

About this task

The following image indicates the connectors on your system board.

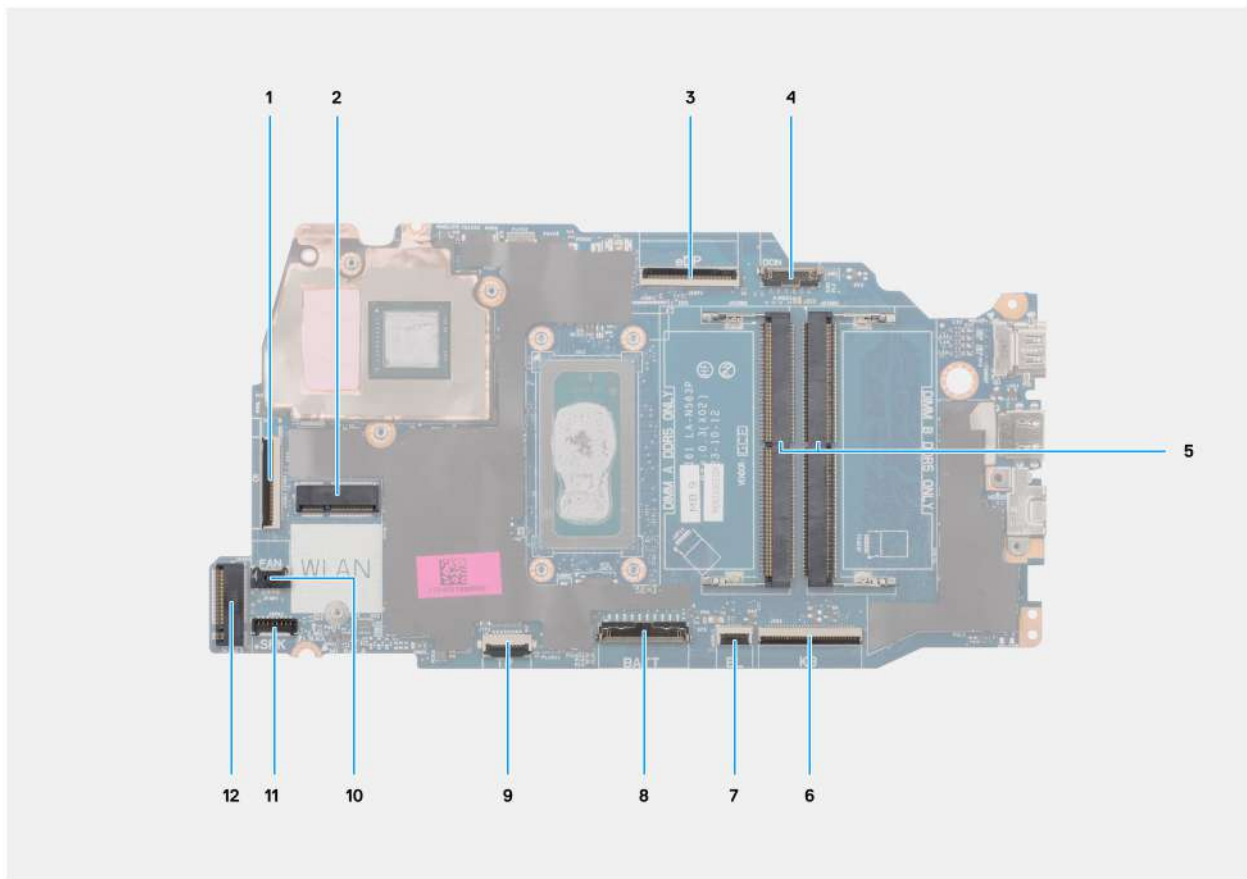

Figure 84. System board connectors

1. I/O-board cable (IO) connector
2. Wireless card (WLAN) connector
3. Display cable (eDP) connector
4. Power-adapter port (DCIN) connector
5. Memory module x2 (DIMM A DDR5 ONLY + DIMM B DDR5 ONLY) connectors
6. Keyboard cable (KB) connector
7. Keyboard-backlight cable (BL) connector
8. Battery cable (BATT) connector
9. Touchpad cable (TP) connector
10. Fan cable (FAN) connector
11. Speaker cable (SPK) connector
12. Solid state drive (SSD) connector

The following images indicate the location of the system board and provide a visual representation of the installation procedure.

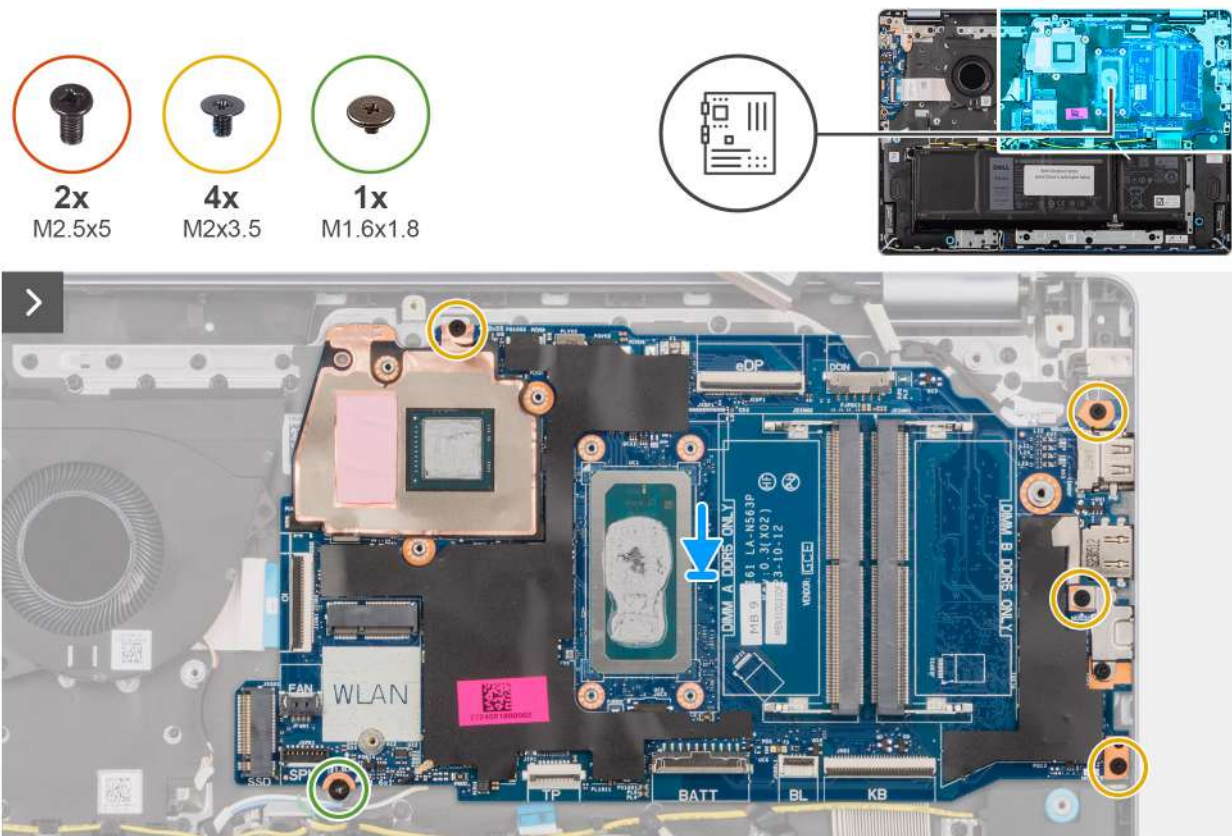

Figure 85. Installing the system board

Steps

1. At an angle, carefully slide and place the system board on the palm-rest and keyboard assembly.
2. Align the ports on the system board to the port slots on the palm-rest and keyboard assembly.
3. Align the screw holes on the system board with the screw holes on the palm-rest and keyboard assembly.
4. Replace the (M1.6x1.8) and the four screws (M2x3.5) to secure the system board to the palm-rest and keyboard assembly.
5. Connect the following cables to the system board:
 - a. display cable (eDP)
 - b. power-adapter port cable (DCIN)
 - c. keyboard cable (KB)
 - d. keyboard-backlight cable (BL)
 - e. battery cable (BATT)
 - f. touchpad cable (TP)
 - g. speaker cable (SPK)
 - h. fan cable (FAN)
 - i. I/O-board cable (IO)

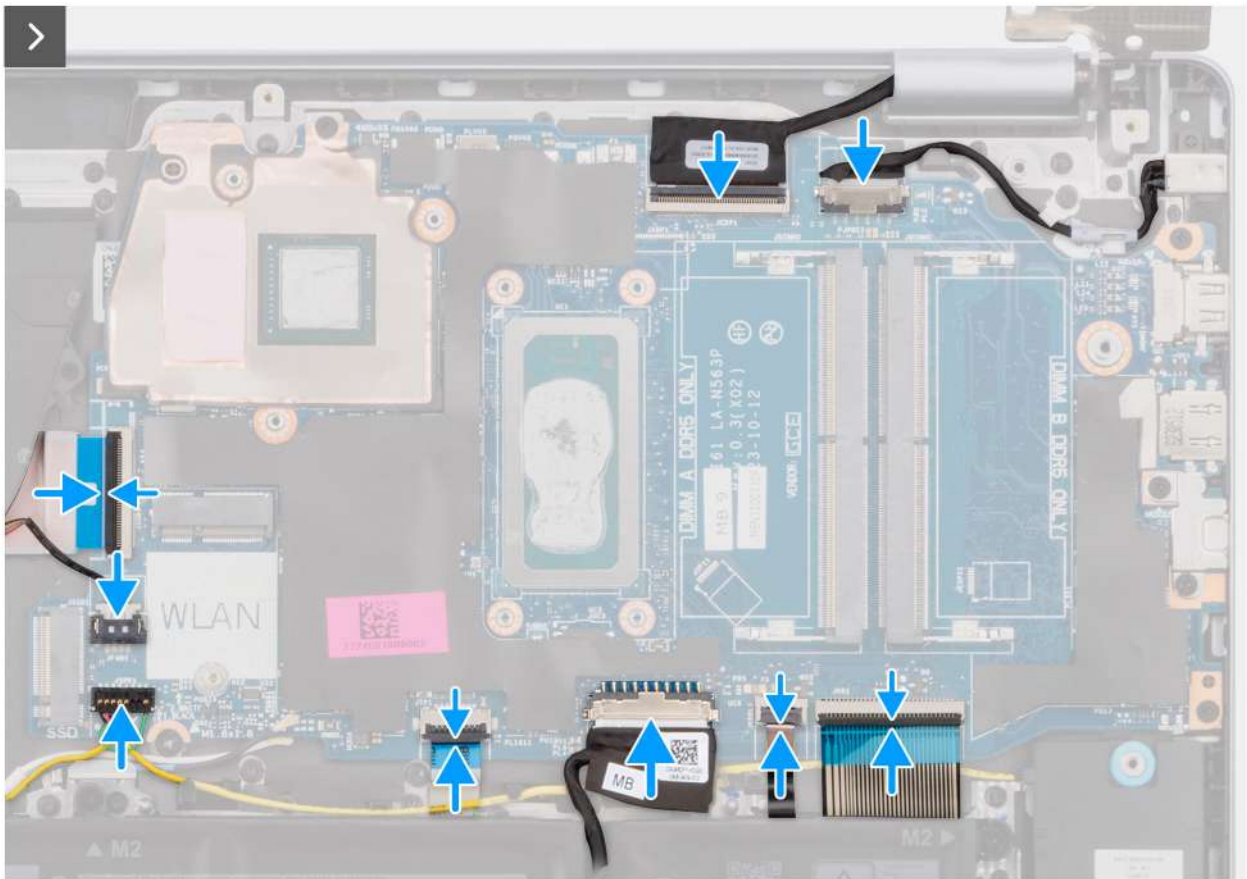

Figure 86. Installing the system board

6. Close the left-display hinge to align the screw holes on the left-display hinge with the screw holes on the system board and the palm-rest and keyboard assembly.
7. Replace the two screws (M2.5x5) that secure the left-display hinge to the palm-rest and keyboard assembly.



Figure 87. Installing the system board

Next steps

1. Install the [heat sink](#) - for computers shipped with integrated graphics card or [heat sink](#) - for computers shipped with discrete graphics card, whichever is applicable.
2. Install the [wireless card](#).
3. Install the [solid state drive](#).
4. Install the [memory module](#).

5. Install the [base cover](#).
6. Follow the procedure in [After working inside your computer](#).

Palm-rest and keyboard assembly

Removing the palm-rest and keyboard assembly

 **CAUTION:** The information in this section is intended for authorized service technicians only.

Prerequisites

1. Follow the procedure in [Before working inside your computer](#).
2. Remove the [base cover](#).
3. Remove the [3-cell battery](#) or [4-cell battery](#), whichever is applicable.
4. Remove the [memory module](#).
5. Remove the [solid state drive](#).
6. Remove the [wireless card](#).
7. Remove the [speakers](#).
8. Remove the [fan](#).
9. Remove the [heat sink - for computers shipped with integrated graphics card](#) or [heat sink - for computers shipped with discrete graphics card](#), whichever is applicable.
10. Remove the [touchpad](#).
11. Remove the [I/O-board cable](#).
12. Remove the [I/O board](#).
13. Remove the [display assembly](#).
14. Remove the [display bezel](#).
15. Remove the [display panel](#).
16. Remove the [display cable](#).
17. Remove the [camera](#).
18. Remove the [display back-cover and antenna assembly](#).
19. Remove the [power button](#) or the [power button with fingerprint reader](#), whichever is applicable.
20. Remove the [power-adaptor port](#).
21. Remove the [system board](#).

 **NOTE:** The system board can be removed with the heat sink attached to it in order to simplify the procedure and preserve the thermal bond between the system board and heat sink.

About this task

 **NOTE:** The palm-rest and keyboard assembly cannot be further disassembled once all the components in the **Prerequisites** have been removed. If the keyboard is malfunctioning and is required to be replaced, replace the entire palm-rest and keyboard assembly.

The image below shows the palm-rest and keyboard assembly after the **Prerequisites** have been performed.

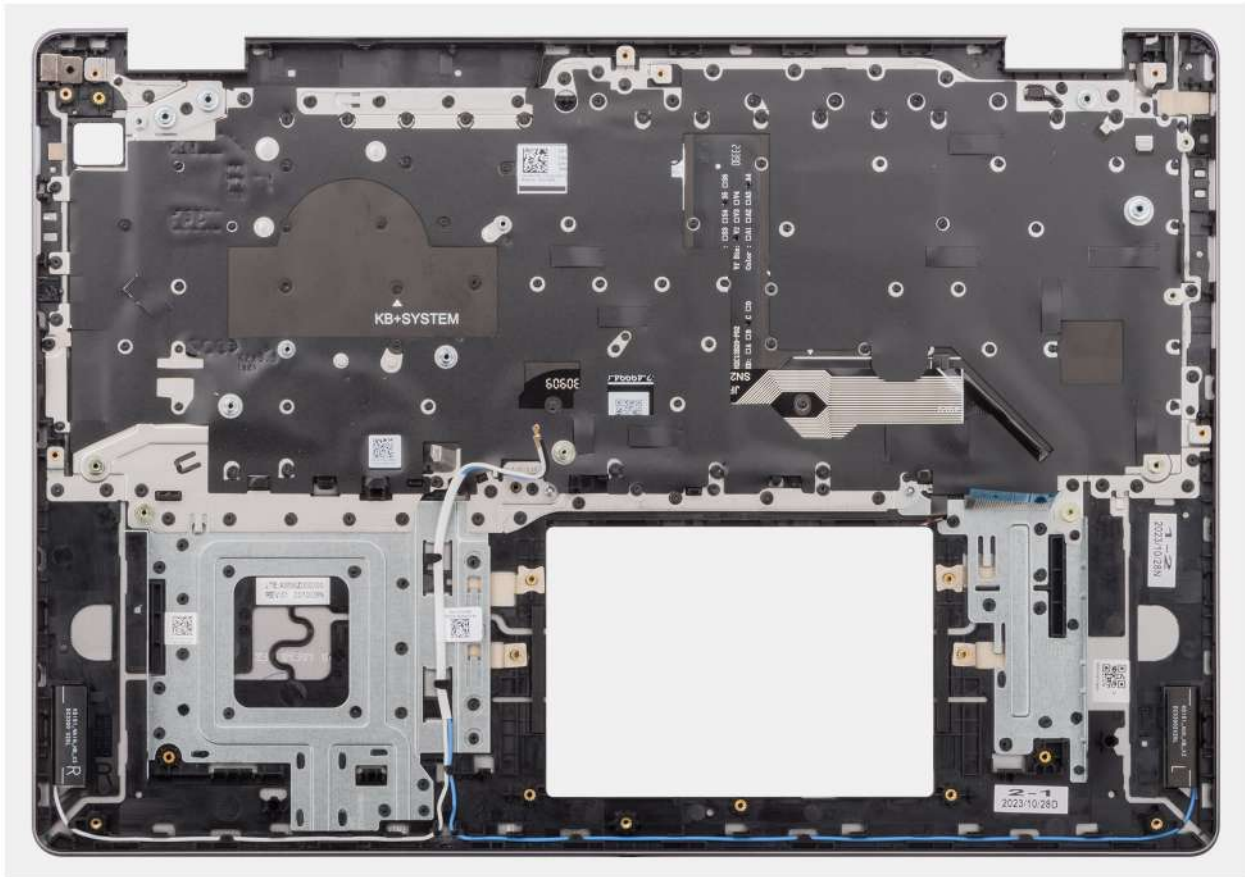

Figure 88. Palm-rest and keyboard assembly

Steps

After performing the **Prerequisites**, you are left with the palm-rest and keyboard assembly.

Installing the palm-rest and keyboard assembly

CAUTION: The information in this section is intended for authorized service technicians only.

Prerequisites

If you are replacing a component, remove the existing component before performing the installation procedure.

About this task

The following image indicates the location of the palm-rest and keyboard assembly and provides a visual representation of the installation procedure.

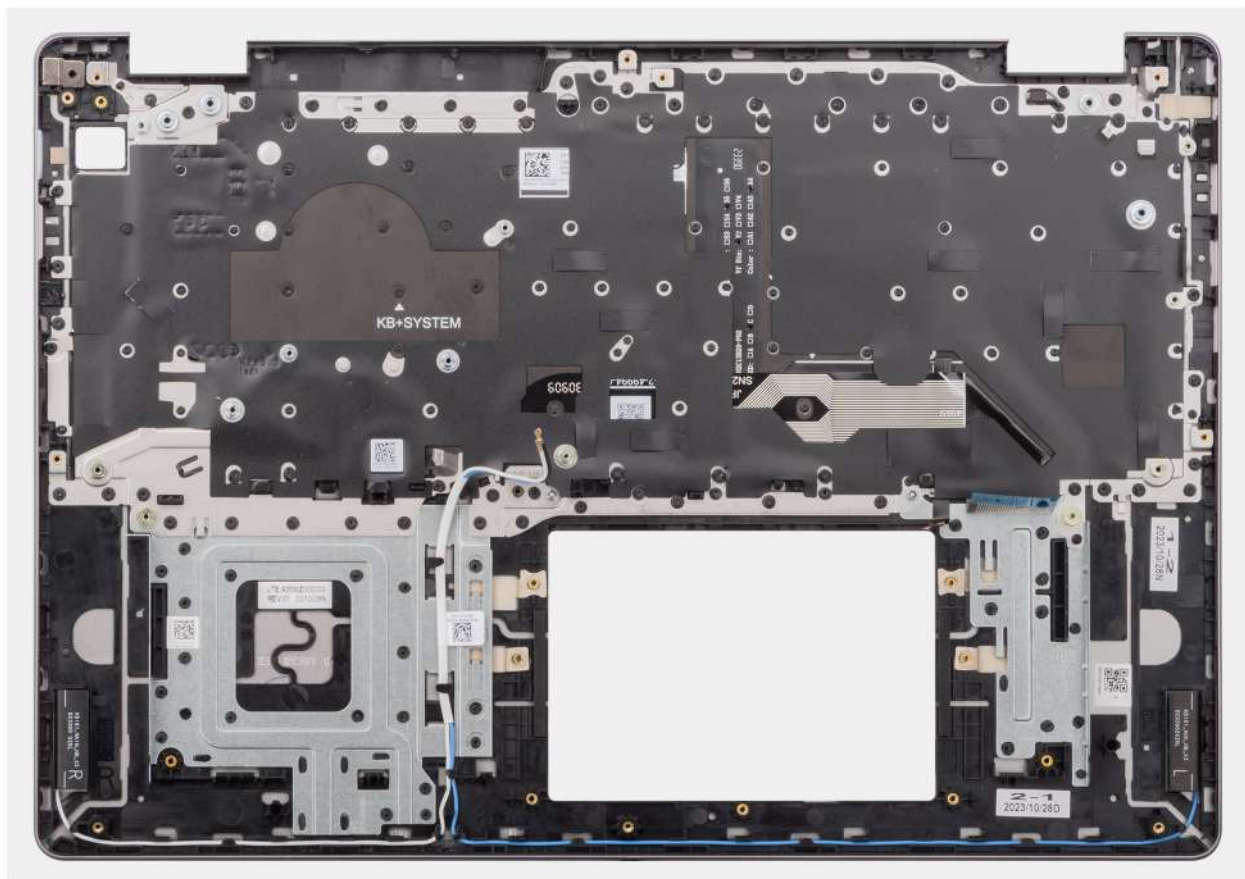

Figure 89. Palm-rest and keyboard assembly

Steps

Place the palm-rest and keyboard assembly on a flat surface and install the components listed in **Next steps** to complete the palm-rest and keyboard assembly installation.

Next steps

1. Install the [system board](#).
2. Install the [power-adapter port](#).
3. Install the [power button](#) or the [power button with fingerprint reader](#), whichever is applicable.
4. Install the [display back-cover and antenna assembly](#).
5. Install the [camera](#).
6. Install the [display cable](#).
7. Install the [display panel](#).
8. Install the [display bezel](#).
9. Install the [display assembly](#).
10. Install the [I/O board](#).
11. Install the [I/O-board cable](#).
12. Install the [touchpad](#).
13. Install the [heat sink - for computers shipped with integrated graphics card](#) or [heat sink - for computers shipped with discrete graphics card](#), whichever is applicable.
14. Install the [fan](#).
15. Install the [speakers](#).
16. Install the [wireless card](#).
17. Install the [solid state drive](#).
18. Install the [memory module](#).
19. Install the [3-cell battery](#) or [4-cell battery](#), whichever is applicable.
20. Install the [base cover](#).

21. Follow the procedure in [After working inside your computer](#).

Software

This chapter details the supported operating systems along with instructions on how to install the drivers.

Operating system

Your Dell 16 DC16250 supports the following operating systems:

- Windows 11 Pro
- Windows 11 Pro National Education
- Windows 11 Home
- Windows 11 Home (S Mode)
- Ubuntu Linux 24.04 LTS, 64-bit

Drivers and downloads

When troubleshooting, downloading, or installing drivers, it is recommended that you read the [Dell Knowledge Base article Drivers and Downloads FAQs](#).

BIOS Setup

CAUTION: Certain changes can make your computer work incorrectly. Before you change the settings in BIOS Setup, it is recommended that you note down the original settings for future reference.

NOTE: Depending on the computer and the installed devices, the options that are listed in this section may differ.

Use BIOS Setup for the following purposes:

- Get information about the hardware installed in your computer, such as the amount of RAM and the capacity of the storage device.
- Change the system configuration information.
- Set or change user-selectable options such as the user password, enabling or disabling base devices, and configuring hard drive settings.

Entering BIOS Setup program

Turn on or restart your computer and press F2 immediately.

Navigation keys

NOTE: For most of the BIOS Setup options, changes that you make are recorded but do not take effect until you restart the computer.

Table 31. Navigation keys

Keys	Navigation
Up arrow	Moves to the previous field.
Down arrow	Moves to the next field.
Enter	Selects a value in the selected field (if applicable) or follows the link in the field.
Spacebar	Expands or collapses a drop-down list, if applicable.
Tab	Moves to the next focus area.
Esc	Moves to the previous page until you view the main screen. Pressing Esc in the main screen displays a message that prompts you to save any unsaved changes and restart the computer.

F12 One Time Boot menu

To enter the One Time Boot menu, turn on or restart your computer, and then press F12 immediately.

NOTE: If you are unable to enter the One Time Boot menu, repeat the above action.

The One Time Boot menu displays the devices that you can boot from and also display the options to start diagnostics. The boot menu options are:

- Removable Drive (if available)
- STXXXX Drive (if available)

 **NOTE:** XXXX denotes the SATA drive number.

- Optical Drive (if available)
- SATA Hard Drive (if available)
- Diagnostics

The One Time Boot menu screen also displays the option to access BIOS Setup.

System setup options

 **NOTE:** Depending on your computer and its installed devices, the items that are listed in this section may or may not be displayed.

Table 32. System setup options—Overview menu

Overview	
Dell 16 DC16250	
BIOS Version	Displays the BIOS version number.
Service Tag	Displays the Service Tag of the computer.
Asset Tag	Displays the Asset Tag of the computer.
Manufacture Date	Displays the manufacture date of the computer.
Ownership Date	Displays the ownership date of the computer.
Express Service Code	Displays the Express Service Code of the computer.
Ownership Tag	Displays the Ownership Tag of the computer.
Battery Information	
Primary	Displays the primary battery of the computer.
Battery Level	Displays the battery level of the computer.
Battery State	Displays the battery state of the computer.
Health	Displays the battery health of the computer.
AC Adapter	Displays whether an AC adapter is connected. If connected, displays the type of AC adapter that is connected.
Battery Life Type	Displays the battery life of the computer.
Processor Information	
Processor Type	Displays the processor type.
Maximum Clock Speed	Displays the maximum processor clock speed.
Processor L2 Cache	Displays the processor L2 cache size.
Processor L3 Cache	Displays the processor L3 cache size.
Memory Information	
Memory Installed	Displays the total memory installed on the computer.
Memory Speed	Displays the memory speed.
DIMM A Size	Displays the size of the memory module installed in the DIMM A slot.
DIMM B Size	Displays the size of the memory module installed in the DIMM B slot.
Devices Information	
Panel Type	Displays the type of display panel available on the computer.

Table 32. System setup options—Overview menu (continued)

Overview	
Video Controller	Displays the type of video controller available on the computer.
Video Memory	Displays information about available video memory on the computer.
Wi-Fi Device	Displays information about available wireless device on the computer.
Native Resolution	Displays information about the native resolution of the display.
Audio Controller	Displays the type of audio controller available on the computer.
Bluetooth Device	Displays information about the wireless device available on the computer.
dGPU Video Controller	Displays the information about discrete graphic card available on the computer.

Table 33. System setup options—Boot Configuration menu



Boot Configuration	
Boot Sequence	
Boot Sequence	<p>Displays the boot sequence.</p> <p> NOTE: Legacy Boot mode is not supported on this platform.</p>
Secure Boot	
	<p>Secure Boot is a method of guaranteeing the integrity of the boot path by performing additional validation of the operating system. The computer stops booting to the operating system when a component is not authenticated during the boot process.</p>
Enable Secure Boot	<p>Enables the computer to boot using only validated boot software.</p> <p>By default, the Enable Secure Boot option is enabled.</p> <p>For additional security, Dell Technologies recommends keeping the Secure Boot option enabled to ensure that the UEFI firmware validates the operating system during the boot process.</p>
Enable Microsoft UEFI CA	<p>When disabled, the UEFI CA is removed from the BIOS UEFI Secure Boot database.</p> <p> CAUTION: When disabled, the Microsoft UEFI CA can cause your computer to not boot, computer graphics may not function, some devices may not function properly, and the computer could become unrecoverable.</p> <p>By default, the Enable Microsoft UEFI CA option is enabled.</p> <p>For additional security, Dell Technologies recommends keeping the Enable Microsoft UEFI CA option enabled to ensure the broadest compatibility with devices and operating systems.</p>
Secure Boot Mode	<p>Enables or disables the Secure Boot operation mode.</p> <p>By default, the Deployed Mode is selected.</p> <p> NOTE: Deployed Mode should be selected for normal operation of Secure Boot.</p>

Table 34. System setup options—Integrated Devices menu

Integrated Devices	
Date/Time	
Date	Sets the computer date in MM/DD/YYYY format. Changes to the date format take effect immediately.
Time	Sets the computer time in HH/MM/SS 24-hour format. You can switch between a 12-hour and 24-hour clock. Changes to the time format take effect immediately.

Table 34. System setup options—Integrated Devices menu (continued)

Integrated Devices	
USB Configuration	
Enable USB Boot Support	Enables booting from USB mass storage devices that are connected to external USB ports. By default, the Enable USB Boot Support option is enabled.

Table 35. System setup options—Storage menu

Storage	
Drive Information	
M.2 PCIe SSD-0	Displays information about the M.2 PCIe SSD-0 type and device.

Table 36. BIOS Setup options—Power menu

Power	
Lid Switch	
Enable Lid Switch	Enables or disables the Lid Switch. By default, the Enable Lid Switch option is enabled.

Table 37. System setup options—Security menu

Security	
Absolute	Absolute Software provides various cyber security solutions, some requiring software preloaded on Dell computers and integrated into the BIOS. To use these features, you must enable the Absolute BIOS setting and contact Absolute for configuration and activation. By default, the Absolute option is enabled. For additional security, Dell Technologies recommends keeping the Enable Absolute option enabled.  NOTE: When the Absolute features are activated, the Absolute integration cannot be disabled from the BIOS setup screen.

Table 38. System setup options—Passwords menu

Passwords	
Admin Password	Enables the user to set, change, or delete the administrator (admin) password. The administrator password enables several security features. Dell Technologies recommends using an administrator password to prevent unauthorized changes to BIOS setup options.
System Password	Enables the user to set, change, or delete the system password. The system password prevents the computer from booting to an operating system without entering the correct password. Dell Technologies recommends using the computer password in situations where it is likely that a computer may be lost or stolen.
M.2 PCIe SSD-0	Enables the user to set, change, or delete the M.2 PCIe SSD-0 password.

Table 39. System setup options—System Management menu

System Management	
Service Tag	Displays the Service Tag of the computer.

Table 40. System setup options—Keyboard menu

Keyboard	
Keyboard Illumination	<p>Configures the operating mode of the keyboard illumination feature.</p> <p>By default, the Bright option is selected. Enables the keyboard illumination feature at 50% brightness level.</p> <p>Use <Fn>+<F5> hotkey to change this setting during normal system operation.</p>
Keyboard Backlight Timeout on AC	<p>Sets the timeout value for the keyboard backlight when an AC adapter is connected to the computer.</p> <p>By default, the 1 minute option is selected.</p>
Keyboard Backlight Timeout on Battery	<p>Sets the timeout value for the keyboard backlight when the computer is running only on the battery power. The keyboard backlight timeout value is only effective when the backlight is enabled.</p> <p>By default, the 1 minute option is selected.</p>

Table 41. System setup options—Pre-boot Behavior menu

Preboot Behavior	
Adapter Warnings	
Enable Adapter Warnings	<p>Enables or disables the computer to display warning messages when adapters with too little power capacity are detected.</p> <p>By default, the option Enable Adapter Warnings is enabled.</p>
Warnings and Errors	<p>Enables or disables the action to be taken when a warning or error is encountered.</p> <p>By default, the Prompt on Warnings and Errors option is selected.</p> <p> NOTE: Errors deemed critical to the operation of the computer hardware stop the functioning of the computer.</p>

Table 42. System setup options—System Logs menu

System Logs	
BIOS Event Log	
Clear BIOS Event Log	<p>Allows you to select option to keep or clear BIOS events logs.</p> <p>By default, the Keep Log option is selected.</p>
Thermal Event Log	
Clear Thermal Event Log	<p>Allows you to select option to keep or clear thermal events logs.</p> <p>By default, the Keep Log option is selected.</p>
Power Event Log	
Clear Power Event Log	<p>Allows you to select option to keep or clear power events logs.</p> <p>By default, the Keep Log option is selected.</p>

Updating the BIOS

Updating the BIOS in Windows

About this task

CAUTION: If BitLocker is not suspended before updating the BIOS, the BitLocker key is not recognized the next time you reboot the computer. You will then be prompted to enter the recovery key to proceed, and the computer displays a prompt for the recovery key on each reboot. Failure to provide the recovery key can result in data loss or an operating system reinstall. For more information, see the Knowledge Base Resource [Updating the BIOS on Dell systems with BitLocker enabled](#).

CAUTION: Do not turn off the computer during the BIOS flash update process. The computer may not boot if you turn off your computer.

Steps

1. Go to [Dell Support Site](#).
2. Go to **Identify your product or ask support**. In the box, enter the product identifier, model, service request or describe what you are looking for, and then click **Search**.
 - NOTE:** If you do not have the Service Tag, click **Detect This PC**. The site automatically detects your device, and you can then click **Explore Product Support** to go to the support page for your device. You can also use the product ID or manually browse for your computer model.
3. Click **Drivers & Downloads**.
4. Select the operating system installed on your computer.
5. In the **Category** drop-down list, select **BIOS**.
6. Select the latest version of BIOS, and click **Download** to download the BIOS file for your computer.
7. After the download is complete, navigate to the folder where the BIOS update file has been saved.
8. Double-click the BIOS update file and follow the on-screen instructions.
For more information, search in the Knowledge Base Resource at [Dell Support Site](#).

Updating the BIOS using the USB drive in Windows

About this task

CAUTION: If BitLocker is not suspended before updating the BIOS, the BitLocker key is not recognized the next time you reboot the computer. You will then be prompted to enter the recovery key to proceed, and the computer displays a prompt for the recovery key on each reboot. Failure to provide the recovery key can result in data loss or an operating system reinstall. For more information, see the Knowledge Base Resource [Updating the BIOS on Dell systems with BitLocker enabled](#).

CAUTION: Do not turn off the computer during the BIOS flash update process. The computer may not boot if you turn off your computer.

Steps

1. Go to [Dell Support Site](#).
2. Go to **Identify your product or ask support**. In the box, enter the product identifier, model, service request or describe what you are looking for, and then click **Search**.
 - NOTE:** If you do not have the Service Tag, click **Detect This PC**. The site automatically detects your device, and you can then click **Explore Product Support** to go to the support page for your device. You can also use the product ID or manually browse for your computer model.
3. Click **Drivers & Downloads**.

4. Select the operating system installed on your computer.
5. In the **Category** drop-down list, select **BIOS**.
6. Select the latest version of BIOS, and click **Download** to download the BIOS file for your computer.
7. Create a bootable USB drive. For more information, search the Knowledge Base Resource at [Dell Support Site](#).
8. Copy the BIOS Setup program file to the bootable USB drive.
9. Connect the bootable USB drive to the computer that needs the BIOS update.
10. Restart the computer and press **F12**.
11. Select the USB drive from the **One Time Boot Menu**.
12. Type the BIOS Setup program filename and press **Enter**.
The **BIOS Update Utility** appears.
13. Follow the on-screen instructions to complete the BIOS update.

Updating the BIOS in Linux and Ubuntu

To update the system BIOS on a computer that is installed with Linux or Ubuntu, see [How to Update the Dell BIOS in the Ubuntu or Linux Environment](#) at [Dell Support Site](#).

Updating the BIOS from the One-Time boot menu

To update the BIOS from the One-Time boot menu, see Knowledge base article [000128928](#) at [Dell Support Site](#).

System and admin password

 **CAUTION:** The password features provide a basic level of security for the data on your computer.

 **CAUTION:** Ensure that your computer is locked when it is not in use. Anyone can access the data that is stored on your computer, when left unattended.

Table 43. System and admin password

Password type	Description
System password	Password that you must enter to boot to your operating system.
Admin password	Password that you must enter to access and change the BIOS settings of your computer.

You can create a system password and admin password to secure your computer.

 **NOTE:** The System and admin password feature is disabled by default.

Assigning a System Setup password

Prerequisites

You can assign a new System or Admin Password only when the status is set to **Not Set**. To enter BIOS System Setup, press F2 immediately after a power-on or reboot.

Steps

1. In the **System BIOS** or **System Setup** screen, select **Passwords** and press Enter.
The **Passwords** screen is displayed.
2. Select **System/Admin Password** and create a password in the **Enter the new password** field.
Use the following guidelines to create the system password:
 - Password can be up to 32 characters.

- Password must contain at least one special character: "(! " # \$ % & ' * + , - . / : ; < = > ? @ [\] ^ _ ` { | })"
 - The password can contain numbers from 0 to 9.
 - The password can contain alphabets A to Z and a to z.
3. Type the system password that you entered earlier in the **Confirm new password** field and click **OK**.
 4. Press Y to save the changes.
The computer restarts.

Deleting or changing an existing system password or admin password

Prerequisites

Ensure that the **Password Status** is Unlocked in the System Setup before attempting to delete or change the existing system password and/or admin password. You cannot delete or change an existing system password or admin password if the **Password Status** is Locked. To enter the System Setup, press F2 immediately after a power-on or reboot.

Steps

1. In the **System BIOS** or **System Setup** screen, select **Passwords** and press Enter.
The **Passwords** screen is displayed.
2. In the **Passwords** screen, verify that the **Password Status** is Unlocked.
3. Select **System Password**. Update or delete the existing system password, and press Enter or Tab.
4. Select **Admin Password**. Update or delete the existing admin password, and press Enter or Tab.
 **NOTE:** If you change the system password and/or Admin password, reenter the new password when prompted. If you delete the system password and/or Admin password, confirm the deletion when prompted.
5. Press Esc. A message prompts you to save the changes.
6. Press Y to save the changes and exit from **System Setup**.
The computer restarts.

Clearing system and admin passwords

About this task

To clear the system or admin passwords, contact Dell technical support as described at [Contact Support](#).

-  **NOTE:** For information about how to reset Windows or application passwords, see the documentation accompanying Windows or your application.

Troubleshooting

Handling swollen rechargeable Li-ion batteries

Like most laptops, Dell laptops use Lithium-ion batteries. One type of Lithium-ion battery is the rechargeable Li-ion battery. Rechargeable Li-ion batteries have increased in popularity in recent years and have become a standard in the electronics industry due to customer preferences for a slim form factor (especially with newer ultra-thin laptops) and long battery life. Inherent to rechargeable Li-ion battery technology is the potential for swelling of the battery cells.

A swollen battery may impact the performance of the laptop. To prevent possible further damage to the device enclosure or internal components leading to malfunction, discontinue the use of the laptop and discharge it by disconnecting the AC adapter and letting the battery drain.

Swollen batteries should not be used and must be replaced and disposed of properly. We recommend contacting Dell Support for options to replace a swollen battery under the terms of the applicable warranty or service contract, including options for replacement by a Dell authorized service technician.

The guidelines for handling and replacing rechargeable Li-ion batteries are as follows:

- Exercise caution when handling rechargeable Li-ion batteries.
- Discharge the battery before removing it from the laptop. To discharge the battery, unplug the AC adapter from the computer and operate the computer only on battery power. The battery is fully discharged when the computer no longer turns on when the power button is pressed.
- Do not crush, drop, mutilate, or penetrate the battery with foreign objects.
- Do not expose the battery to high temperatures, or disassemble battery packs and cells.
- Do not apply pressure to the surface of the battery.
- Do not bend the battery.
- Do not use tools of any type to pry on or against the battery.
- If a battery gets stuck in a device as a result of swelling, do not try to free it as puncturing, bending, or crushing a battery can be dangerous.
- Do not attempt to reassemble a damaged or swollen battery into a laptop.
- Swollen batteries that are covered under warranty should be returned to Dell in an approved shipping container (provided by Dell)—this is to comply with transportation regulations. Swollen batteries that are not covered under warranty should be disposed of at an approved recycling center. Contact Dell Support at [Dell Support Site](#) for assistance and further instructions.
- Using a non-Dell or incompatible battery may increase the risk of fire or explosion. Replace the battery only with a compatible battery purchased from Dell that is designed to work with your Dell computer. Do not use a battery from other computers with your computer. Always purchase genuine batteries from [Dell Site](#) or otherwise directly from Dell.

Rechargeable Li-ion batteries can swell for various reasons such as age, number of charge cycles, or exposure to high heat. For more information about how to improve the performance and lifespan of the laptop battery and to minimize the possibility of occurrence of the issue, search Dell laptop battery at [Dell Support Site](#).

Dell SupportAssist Pre-boot System Performance Check diagnostics

About this task

SupportAssist diagnostics (also known as system diagnostics) performs a complete check of your hardware. The Dell SupportAssist Pre-boot System Performance Check diagnostics is embedded within the BIOS and launched by the BIOS internally. The embedded system diagnostics provides options for particular devices or device groups allowing you to:

- Run tests automatically or in an interactive mode.
- Repeat the tests.
- Display or save test results.
- Run thorough tests to add more options and obtain details about any failed devices.

- View status messages that inform you when the tests are completed successfully.
- View error messages that inform you of problems encountered during testing.

NOTE: Some tests for specific devices require user interaction. Always ensure that you are present at the computer when the diagnostic tests are performed.

For more information, see [How to Run Dell Preboot Diagnostics and Hardware Tests on Your Dell Computer](#).

Running the SupportAssist Pre-Boot System Performance Check

Steps

1. Turn on your computer.
2. As the computer boots, press the F12 key.
3. On the boot menu screen, select **Diagnostics**.
The diagnostic quick test begins.
NOTE: For more information about running the SupportAssist Pre-Boot System Performance Check on a specific device, see [Dell Support Site](#).
4. If there are any issues, error codes are displayed.
Note the error code and validation number and contact Dell.

Built-in self-test (BIST)

Motherboard Built-In Self-Test (M-BIST)

M-BIST is the system board onboard self-test diagnostics tool that improves the diagnostics accuracy of system board Embedded Controller (EC) failures.

NOTE: M-BIST can be manually initiated before Power On Self-Test (POST).

How to run M-BIST

NOTE: Before initiating M-BIST, ensure that the computer is in a power-off state.

1. Press and hold both the **M** key and the power button to initiate M-BIST.
2. The battery-status light may exhibit two states:
 - Off: No fault was detected.
 - Amber and White: Indicates a problem with the system board.
3. If there is a failure with the system board, the battery-status light flashes one of the following error codes for 30 seconds:

Table 44. LED error codes

Blinking Pattern		Possible Problem
Amber	White	
2	1	CPU Failure
2	8	LCD Power Rail Failure
1	1	TPM Detection Failure
2	4	Memory/RAM failure

4. If there is no failure with the system board, the LCD cycles through the solid color screens (that are described in the LCD-BIST) for 30 seconds and then turn off.

Logic Built-in Self-test (L-BIST)

L-BIST is an enhancement to the single LED error code diagnostics and is automatically initiated during POST. L-BIST will check the LCD power rail. If there is no power being supplied to the LCD (that is if the L-BIST circuit fails), the battery status LED flashes either an error code [2,8] or an error code [2,7].

NOTE: If L-BIST fails, LCD-BIST cannot function as no power will be supplied to the LCD.

How to invoke the L-BIST

1. Turn on your computer.
2. If the computer does not start up normally, look at the battery status LED:
 - If the battery status LED flashes an error code [2,7], the display cable may not be connected properly.
 - If the battery status LED flashes an error code [2,8], there is a failure on the LCD power rail of the system board, hence there is no power that is supplied to the LCD.
3. For cases, when a [2,7] error code is shown, check to see if the display cable is properly connected.
4. For cases when a [2,8] error code is shown, replace the system board.

LCD Built-in Self-Test (LCD-BIST)

Dell laptops have a built-in diagnostic tool that helps you determine if the screen abnormality you are experiencing is an inherent problem with the LCD (screen) of the Dell laptop or with the video card (GPU) and computer settings.

When you notice screen abnormalities like flickering, distortion, clarity issues, fuzzy or blurry image, horizontal or vertical lines, color fade, it is always a good practice to isolate the LCD (screen) by running the LCD-BIST.

How to invoke the LCD-BIST

1. Turn off your computer.
2. Disconnect any peripherals that are connected to the computer. Connect only the AC adapter (charger) to the computer.
3. Ensure that the LCD (screen) is clean (no dust particles on the surface of the screen).
4. Press and hold the **D** key and press the power button to enter LCD-BIST mode. Continue to hold the **D** key until the computer boots up.
5. The screen displays solid colors and changes colors on the entire screen to white, black, red, green, and blue twice.
6. Then it displays the colors white, black, and red.
7. Carefully inspect the screen for abnormalities (any lines, fuzzy color, or distortion on the screen).
8. At the end of the last solid color (red), the computer shuts down.

NOTE: Dell SupportAssist Preboot diagnostics upon launch initiates an LCD-BIST first, expecting a user intervention to confirm functionality of the LCD.

System-diagnostic lights

This section lists the system-diagnostic lights of your Dell 16 DC16250.

Table 45. System-diagnostic lights

Blinking pattern		Problem description
Amber	White	
1	1	TPM detection failure
1	2	Unrecoverable SPI Flash Failure
1	3	Short in hinge cable tripped OCP1
1	4	Short in hinge cable tripped OCP2
1	5	EC unable to program i-Fuse

Table 45. System-diagnostic lights (continued)

Blinking pattern		Problem description
Amber	White	
1	6	Generic catch-all for ungraceful EC code flow errors
1	7	Non-RPMC Flash on Boot Guard fused system
1	8	Chipset "Catastrophic Error" signal has tripped
2	1	CPU failure
2	2	System board failure (included BIOS corruption or ROM error)
2	3	No memory or RAM detected
2	4	Memory or RAM failure
2	5	Invalid memory installed
2	6	System board or chipset error
2	7	LCD failure (SBIOS message)
2	8	LCD failure (EC detection of power rail failure)
3	2	PCI or Video card or chip failure
3	3	BIOS Recovery image not found
3	4	BIOS Recovery image found but invalid.
3	5	Power rail failure
3	6	Flash corruption is detected by SBIOS.
3	7	Timeout waiting on ME to reply to HECI message.
4	3	Display panel failure
4	4	Cable and display power rail failure
4	5	Display power rail, cable, and display panel failure
4	6	Display cable failure

NOTE: Blinking 3-3-3 LEDs on Lock LED (Caps-Lock or Num Lock), Power button LED (without Fingerprint reader), and Diagnostic LED indicates failure to provide input during LCD panel test on Dell SupportAssist Preboot System Performance. Check diagnostics.

Recovering the operating system

When your computer is unable to boot to the operating system even after repeated attempts, it automatically starts Dell SupportAssist OS Recovery.

Dell SupportAssist OS Recovery is a stand-alone tool that is preinstalled on Dell computers running the Windows operating system. It consists of tools to diagnose and troubleshoot issues that may occur before your computer boots to the operating system. It enables you to diagnose hardware issues, repair your computer, back up your files, and restore your computer to its factory state.

You can also download it from the Dell Support website to troubleshoot and fix your computer when it fails to boot into the primary operating system due to software or hardware failures.

For more information about the Dell SupportAssist OS Recovery, see *Dell SupportAssist OS Recovery User's Guide* at [Serviceability Tools at the Dell Support Site](#). Click **SupportAssist** and then click **SupportAssist OS Recovery**.

i **NOTE:** Windows 11 IoT Enterprise LTSC 2024 and Dell ThinOS 10 do not support Dell SupportAssist. For more information about recovering ThinOS 10, see [Recovery mode using R-Key](#).

Real-Time Clock (RTC Reset)

The Real-Time Clock (RTC) reset function enables you or the service technician to recover Dell computers from No POST/No Power/No Boot situations.

Start the RTC reset with the computer powered off and connected to AC power. Press and hold the power button for thirty seconds. The computer RTC Reset occurs after you release the power button.

Backup media and recovery options

It is recommended to create a recovery drive to troubleshoot and fix problems that may occur with Windows. Dell provides multiple options for recovering the Windows operating system on your Dell computer. For more information, see [Dell Windows Backup Media and Recovery Options](#).

Network power cycle

About this task

If your computer is unable to access the Internet due to network connectivity issues, reset your network devices by performing the following steps:

Steps

1. Turn off the computer.
2. Turn off the modem.
i **NOTE:** Some Internet service providers (ISPs) provide a modem and router combo device.
3. Turn off the wireless router.
4. Wait for 30 seconds.
5. Turn on the wireless router.
6. Turn on the modem.
7. Turn on the computer.

Drain flea power (perform hard reset)

About this task

Flea power is the residual static electricity that remains in the computer even after it has been powered off and the battery is removed.

For your safety, and to protect the sensitive electronic components in your computer, you must drain residual flea power before removing or replacing any components in your computer.

Draining flea power, also known as performing a "hard reset," is also a common troubleshooting step if your computer does not turn on or boot into the operating system.

Perform the following steps to drain the flea power:

Steps

1. Turn off the computer.
2. Disconnect the power adapter from the computer.

3. Remove the base cover.
4. Remove the battery.

 **CAUTION: The battery is a Field Replaceable Unit (FRU) and the removal and installation procedures are intended for authorized service technicians only.**

5. Press and hold the power button for 20 seconds to drain the flea power.
6. Install the battery.
7. Install the base cover.
8. Connect the power adapter to the computer.
9. Turn on the computer.

 **NOTE:** For more information about performing a hard reset, go to [Dell Support Site](#). On the menu bar at the top of the Support page, select Support > Support Library. In the Search field on the Support Library page, type the keyword, topic, or model number, and then click or tap the search icon to view the related articles.

Getting help and contacting Dell

Self-help resources

You can get information and help on Dell products and services using these self-help resources:

Table 46. Self-help resources

Self-help resources	Resource location
Information about Dell products and services	Dell Site
Contact Support	In Windows search, type <code>Contact Support</code> , and press Enter.
Online help for operating system	Windows Support Site Linux Support Site
Access top solutions, diagnostics, drivers and downloads, and learn more about your computer through videos, manuals, and documents.	Your Dell computer is uniquely identified using a Service Tag or Express Service Code. To view relevant support resources for your Dell computer, enter the Service Tag or Express Service Code at Dell Support Site . For more information about how to find the Service Tag for your computer, see Locate the Service Tag on your computer .
Dell knowledge base articles	<ol style="list-style-type: none"> 1. Go to Dell Support Site. 2. On the menu bar at the top of the Support page, select Support > Support Library. 3. In the Search field on the Support Library page, type the keyword, topic, or model number, and then click or tap the search icon to view the related articles.

Contacting Dell

To contact Dell for sales, technical support, or customer service issues, see [Dell Support Site](#).

 **NOTE:** Availability of the services may vary depending on the country or region, and product.

 **NOTE:** If you do not have an active Internet connection, you can find contact information in your purchase invoice, packing slip, bill, or Dell product catalog.

Revision history

Tracks all updates that are made to the document. It typically includes the date of change, version number, and a brief description of the modification. This log helps maintain transparency, accountability, and a clear timeline of progress.

Table 47. Revision history

Revision	Date	Description
A03	April 2026	Added Quebec requirement information.
A02	December 2025	Updated speaker removal and installation images.
A01	July 2025	Updated MyDell QR description in view section.
A00	May 2025	Original publish date.