

## NOTICE

- \* Please make sure that you have all parts indicated and they are in good condition before you begin assembly of this item. Refer to part list and hardware list below for guidance.
- \* This item should be assembled on a soft surface to prevent scratching the finish during assembly.
- \* This item may require periodic tightening.
- \* If you are having difficulty, our friendly Customer Care team is always here to help. Please email [customersupport@safavieh.com](mailto:customersupport@safavieh.com)















## PREPARATION

- \* Before beginning assembly of product, make sure all parts are present. Compare parts with part contents list and hardware contents list.
- \* If any part is missing or damaged, do not attempt to assemble the product.
- \* Estimated Assembly Time: **20 minutes**.
- \* Tools Required for Assembly (included): **Allen Key, Key**

## CARE AND MAINTENANCE

Store outdoor furniture indoors or cover well when not in use. Remove wooden furniture from standing water. Dust regularly with small brush or vacuum. Spills should be taken care of immediately before they harden or stain with a slightly dampened sponge. Do not use bleach solutions

## Part List and Hardware List

PIECE	DESCRIPTION	PICTURE	QUANTITY
A	Right Bench 3S Frame		1X
B	Left Bench 3S Frame		1X
F	Support Leg		2X
G	Bench Leg		4X
CSH1	Back Cushion		3X
CSH2	Seat Cushion 1		1X
CSH3	Seat Cushion 2		2X
HW1	Allen Bolt: M6 x 0.5 x 20 mm		16X
HW2	Allen Bolt: M6 x 0.5 x 25 mm		1X
HW3	Allen Bolt: M6 x 0.5 x 45 mm		2X
HW4	Flat Washer: M6 x 1 mm		23X
HW5	Plastic Cover		1X
HW6	Nut M6		4X
HW7	Allen Key		1X
HW8	Key		1X

 **SAFAVIEH**  
O U T D O O R

Model# PAT7742

Product Dimensions

77.56"W x 28.35"D x 26.38"H (Bench 3S)

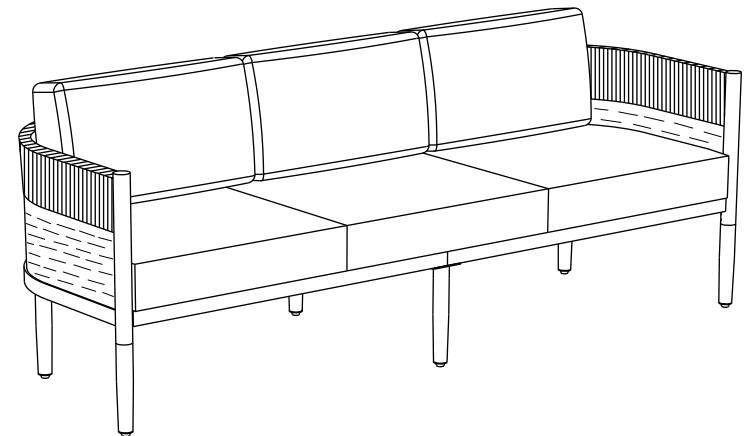

Weight Capacity : 880 lbs (Bench 3S)

Warning : Do not stand on Bench

Warning : Do not over torque bolts/screws

# PREPARATION

- \* Before beginning assembly of product, make sure all parts are present. Compare parts with part contents list and hardware contents list.
- \* If any part is missing or damaged, do not attempt to assemble the product.
- \* Estimated Assembly Time: **25 minutes.**
- \* Tools Required for Assembly (included): **Allen Key, Key**
- \* If you are having difficulty, our friendly Customer Care team is always here to help. Please email [customersupport@safavieh.com](mailto:customersupport@safavieh.com)

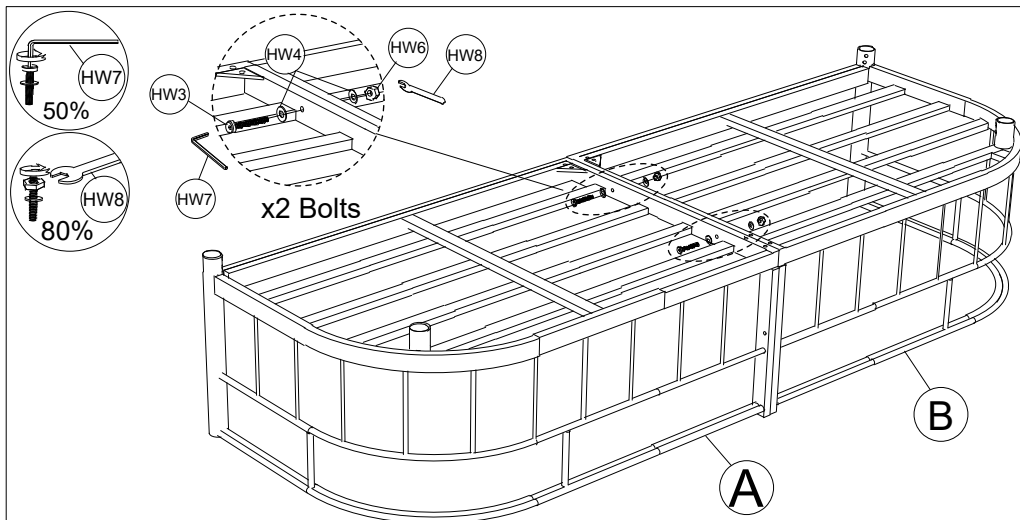

**STEP 1 :** Connect Right Bench 3S Frame (A) & Left Bench 3S Frame (B) by Bolt on frame & tighten Bolt (HW3), Flat Washer (HW4), Nut M6 (HW6) with Alley Key (HW7),Key (HW8).

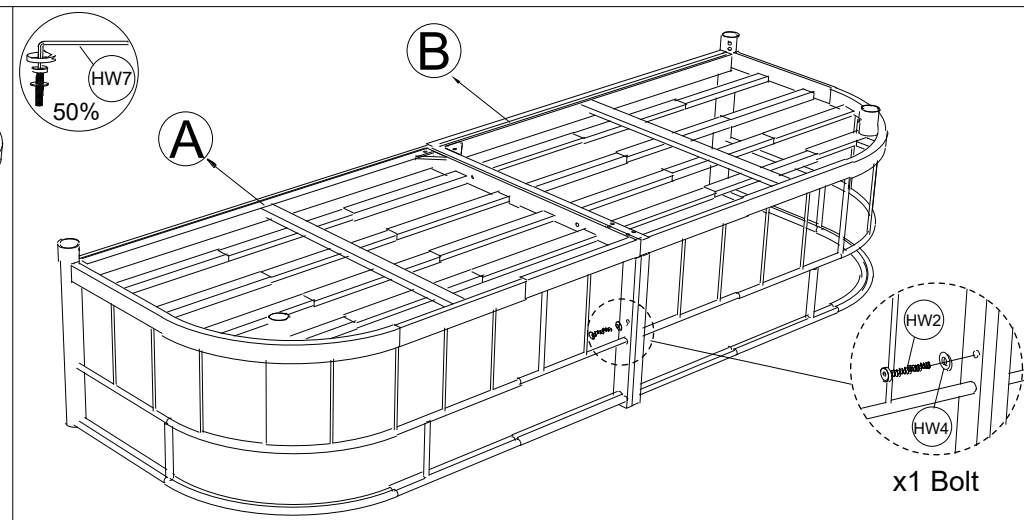

**STEP 2 :** Hold & Connect the part in Step 1, tighten Bolt (HW2), Flat Washer (HW4), with Allen Key (HW7).

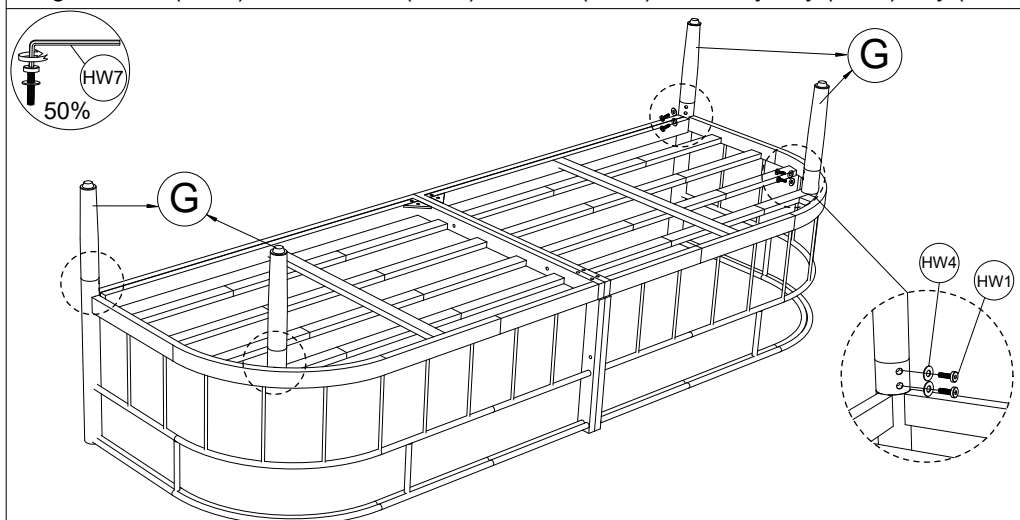

**STEP 3 :** Connect the part from step 2 & Bench Leg (G), tighten Bolt (HW1), Flat Washer (HW4) with Allen Key (HW7).

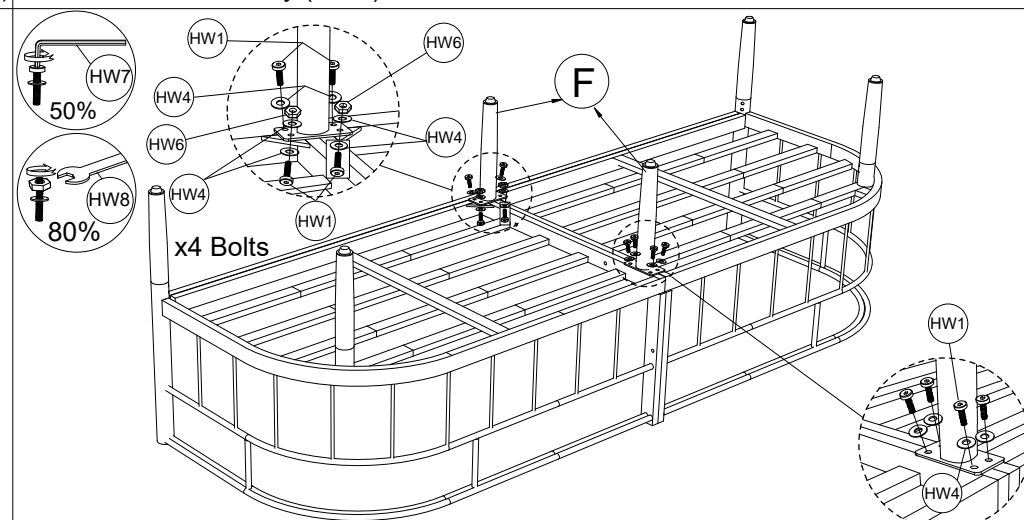

**STEP 4 :** Connect the part from Step 3 & Support Leg (F), tighten Bolt (HW1), Flat Washer (HW4), Nut (HW6) with Allen Key (HW7), Key (HW8).

## PREPARATION

- \* Before beginning assembly of product, make sure all parts are present. Compare parts with part contents list and hardware contents list.
- \* If any part is missing or damaged, do not attempt to assemble the product.
- \* Estimated Assembly Time: **20 minutes.**
- \* Tools Required for Assembly (included): **Allen Key, Key**
- \* If you are having difficulty, our friendly Customer Care team is always here to help. Please email [customersupport@safavieh.com](mailto:customersupport@safavieh.com)

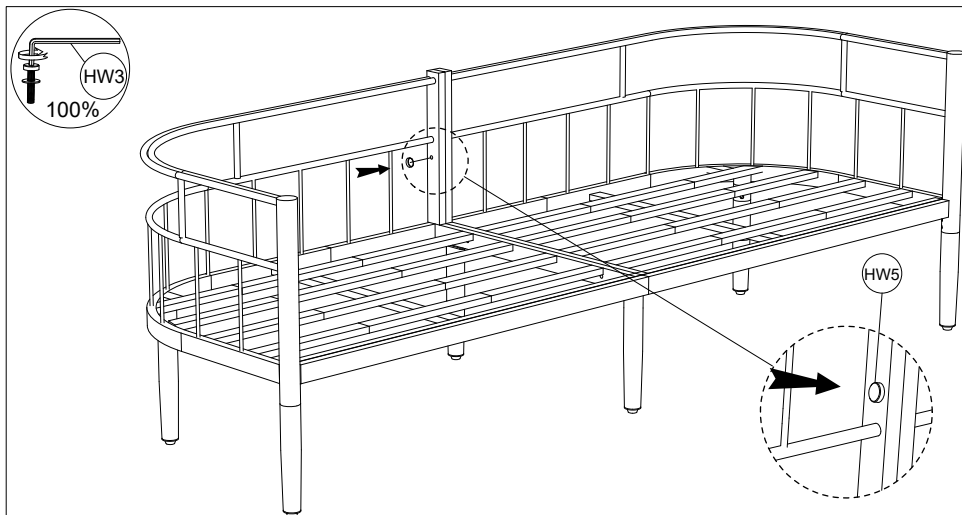

**STEP 5:** Firmly tighten all the Bolts with Allen Key (HW7). Put the Bench upright & tighten the Plastic Cover (HW5) on the Back.

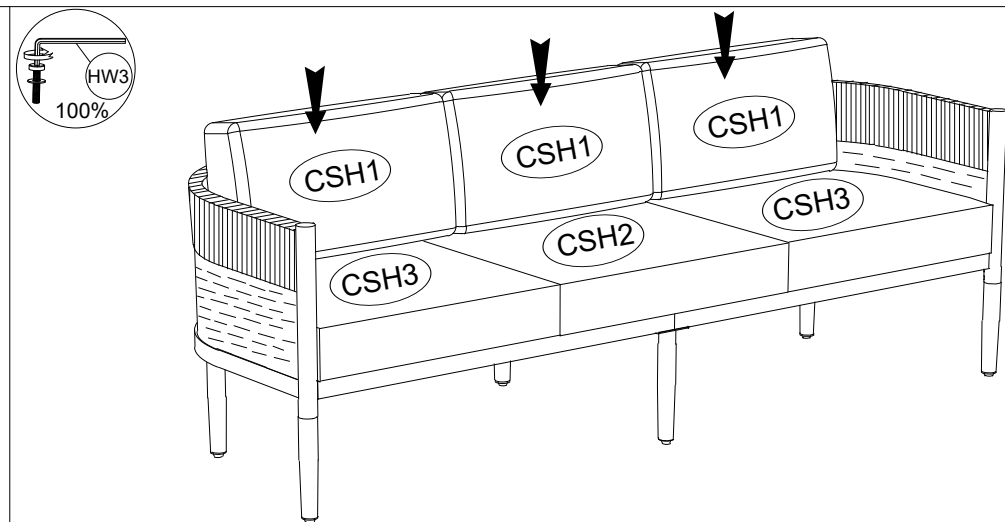

**STEP 6:** Put the Cushion (CSH1), (CSH2), (CSH3) on the Bench 3S.

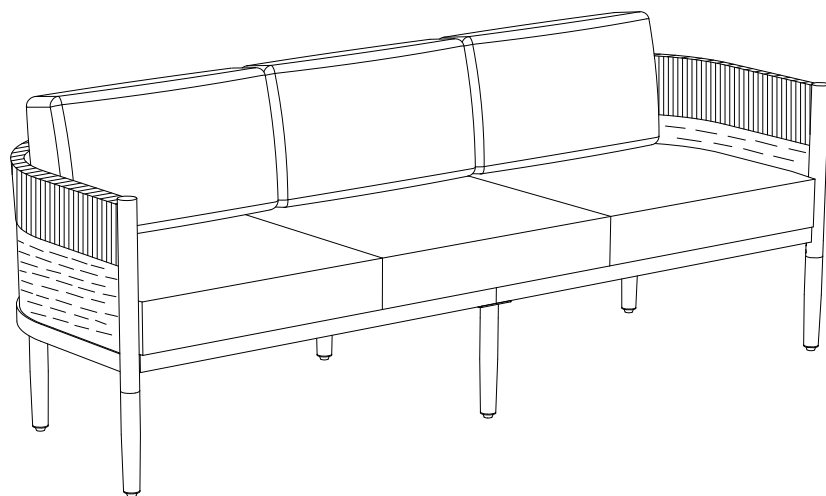

Finish Bench 3S.