

# FREEMOTION<sup>®</sup>

## GLUTE

Model No. ES820.0

Serial No. \_\_\_\_\_

Write the serial number in the space above for reference.

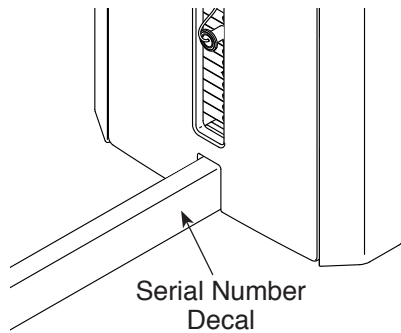

### QUESTIONS?

If you have questions, or if parts are damaged or missing, please see **HOW TO CONTACT CUSTOMER CARE** on the back cover of this manual.

### CAUTION

Read all precautions and instructions in this manual before using this equipment. Keep this manual for future reference.

## OWNER'S MANUAL

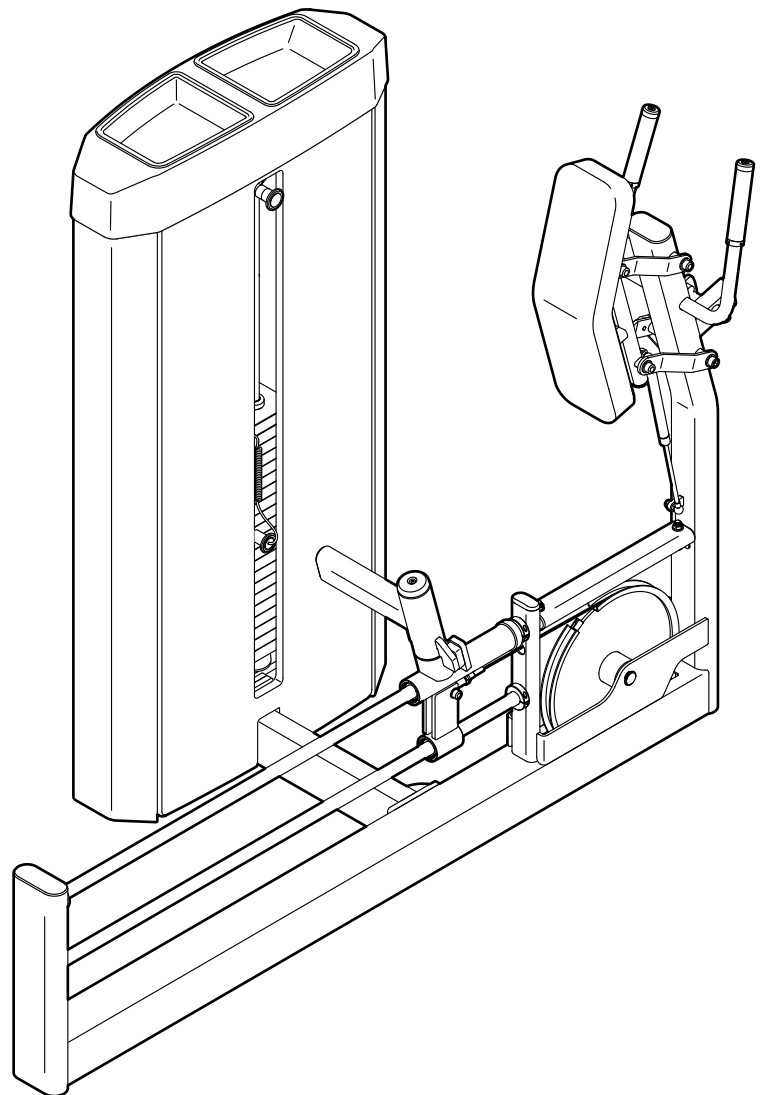

---

# TABLE OF CONTENTS

IMPORTANT PRECAUTIONS.....	3
WARNING DECAL PLACEMENT .....	4
BEFORE YOU BEGIN.....	5
PART IDENTIFICATION CHART.....	6
ASSEMBLY.....	7
ADJUSTMENT .....	15
MAINTENANCE AND TROUBLESHOOTING.....	16
CABLE DIAGRAM.....	18
PART LIST .....	21
EXPLODED DRAWING.....	22
HOW TO CONTACT CUSTOMER CARE.....	Back Cover
LIMITED WARRANTY.....	Back Cover

FREEMOTION is a registered trademark of ICON Health & Fitness, Inc.  
FORMULA 409 is a registered trademark of The Clorox Company.  
SIMPLE GREEN is a registered trademark of Sunshine Makers, Inc.  
Teflon is a registered trademark of E. I. du Pont de Nemours and Company.

---

# IMPORTANT PRECAUTIONS

**⚠️WARNING:** To reduce the risk of serious injury, read all important precautions and instructions in this manual and all warnings on your strength equipment before using your strength equipment. Freemotion Fitness assumes no responsibility for personal injury or property damage sustained by or through the use of this product.

1. It is the responsibility of the owner to ensure that all users of the strength equipment are adequately informed of all precautions, have read and understood all warning and caution labels, and are informed of how to use the strength equipment properly.
2. Before beginning any exercise program, consult your physician. This is especially important for persons over age 35 or persons with pre-existing health problems.
3. Use the strength equipment only as described in this manual.
4. It is the responsibility of the owner to ensure that there is enough space around the strength equipment for the intended exercise.
5. Use the strength equipment only on a level surface. Cover the floor beneath the strength equipment to protect the floor.
6. Anchor the strength equipment to the floor with the anchor strap where required or where possible to provide maximum stability.
7. All users of the strength equipment should be instructed to report any injury or strength equipment irregularity to facility staff immediately.
8. Keep children under age 16 and pets away from the strength equipment at all times.
9. The strength equipment is designed to support a maximum user weight of 350 lbs. (159 kg).
10. Always wear athletic shoes for foot protection while exercising.
11. Keep hands and feet away from moving parts. Do not lean on or rest your hands on the strength equipment while it is in use.
12. Make sure that the weight pin is completely inserted into one of the weights.
13. Make sure that the handles are attached securely before each use of the strength equipment.
14. Check each cable, cable connection, and pulley before each use of the strength equipment. Make sure that all parts are properly tightened. Replace any worn parts immediately.
15. Make sure that each cable remains on the pulleys at all times. If a cable binds while you are exercising, stop immediately and make sure that the cable is on the pulleys and that nothing is interfering with the cable or the pulleys.
16. Over exercising may result in serious injury or death. If you feel faint or if you experience pain while exercising, stop immediately and cool down.

# WARNING DECAL PLACEMENT

This drawing shows the location(s) of the warning decal(s). If a decal is missing or illegible, see the back cover of this manual and request a free replacement decal. Apply the decal in the location shown. Note: The decal(s) may not be shown at actual size.

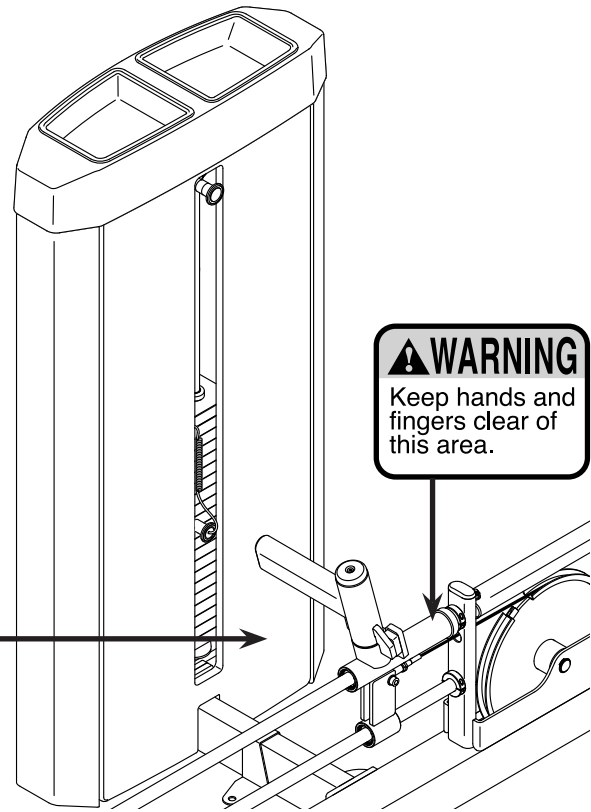

**⚠ WARNING**

- Read and follow all warnings and instructions and obtain proper instruction prior to use.
- Before beginning an exercise program, consult your physician.
- Inspect the machine, cables, straps, and their connections before use. Do not use machine if any component appears to be worn or damaged.
- Back panel must be in place before machine use.
- Keep body and clothing clear of all moving parts.
- Do not use dumbbells or other means to increase the weight resistance, other than those provided by the manufacturer.
- Do not allow children on machine. Machine use by teenagers and adults must be supervised by a qualified adult.
- Do not remove this label; replace if damaged.
- Max user weight: 350 lbs/159kg.

**⚠ WARNING**

- Keep hands and clothing clear of all moving parts.
- Selector pin must be fully inserted into the weight plate.
- Never insert selector pin between weight plates. Never use the machine if found in this condition.
- Failure to heed these warnings could result in personal injury.

**⚠ WARNING**  
Keep hands and fingers clear of this area.

# BEFORE YOU BEGIN

Thank you for selecting the FREEMOTION® GLUTE strength equipment. With natural motion, the GLUTE strength equipment enables you to work your body's muscle groups more effectively and efficiently.

**For your benefit, read this manual carefully before using the strength equipment.** If you have questions after reading this manual, please see the back cover

of this manual. To help us assist you, note the product model number and serial number before contacting us. The model number and the location of the serial number decal are shown on the front cover of this manual.

Before reading further, please review the drawing below and familiarize yourself with the parts that are labeled.

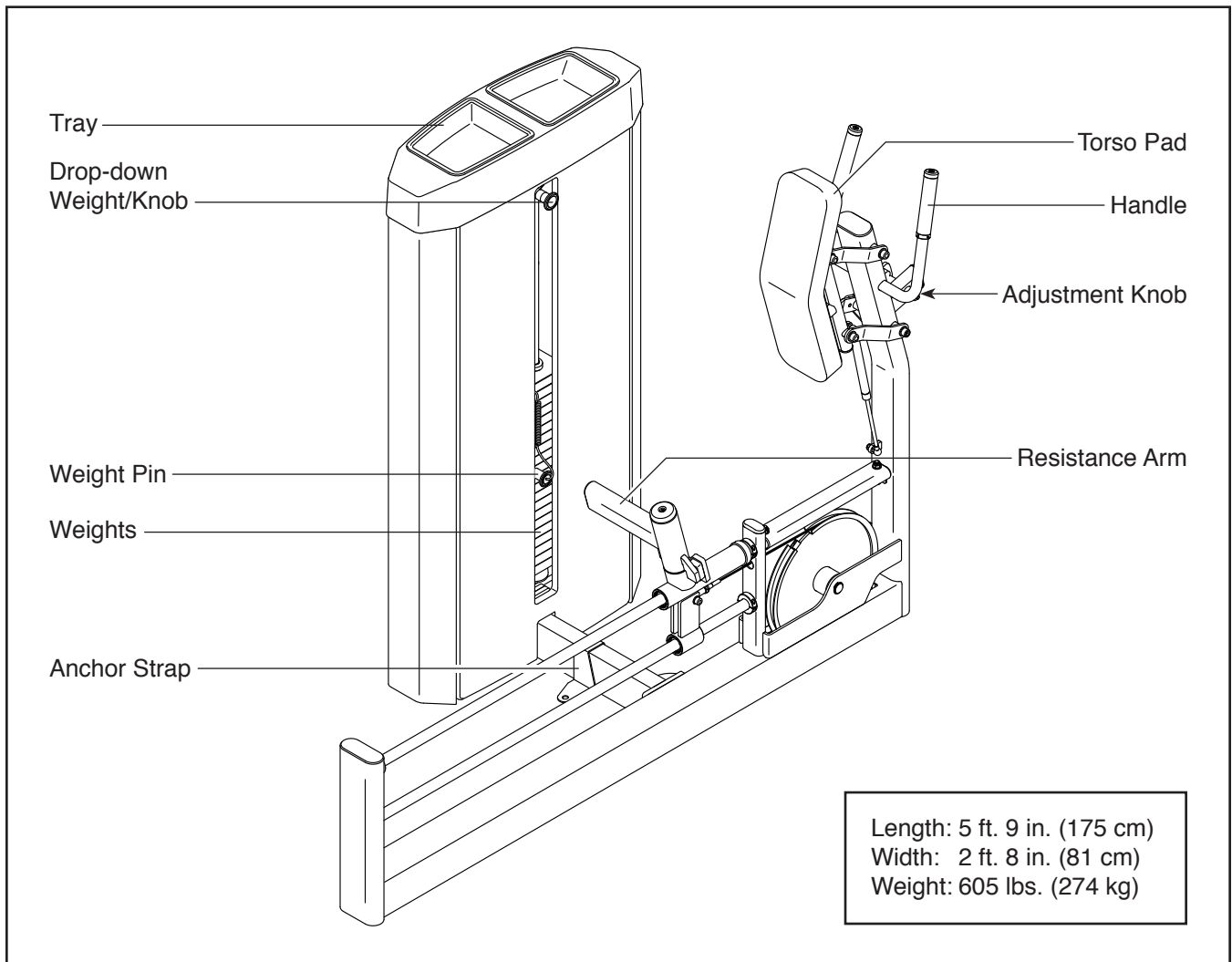

# PART IDENTIFICATION CHART

Use the drawings below to identify small parts used for assembly. The number in parentheses by each drawing is the key number of the part, from the PART LIST near the end of this manual. The number following the parentheses is the quantity needed for assembly. **Note: If a part is not in the hardware kit, check to see whether it has been preattached.**

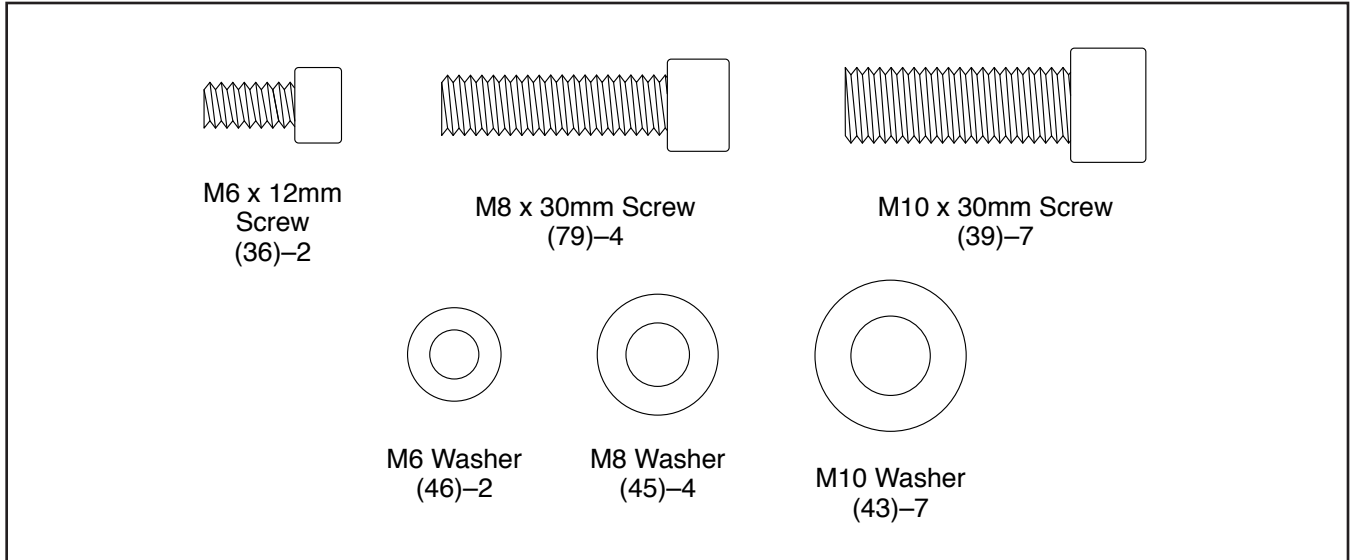

# ASSEMBLY

- Assembly requires two persons.
- Because of its weight and size, assemble the strength equipment in the location where it will be used. Make sure that there is enough clearance around the strength equipment.
- Place all parts in a cleared area and remove the packing materials. Do not dispose of the packing materials until assembly is completed.
- For help identifying small parts, see page 6.

- The following tools (not included) are required for assembly:

one adjustable wrench



one Phillips screwdriver



a set of metric hex keys



Assembly may be more convenient if you have your own set of wrenches. To avoid damaging parts, do not use power tools.

1. Orient the Main Frame (28) and the Connecting Frame (7) as shown. **Have a second person hold the Main Frame to prevent it from falling until you complete step 2.**

Remove the indicated parts (42, 38, 43, 24) from the pulley bracket on the Connecting Frame (7).

Next, locate the Long Cable (31) in the Main Frame (28). Insert the Long Cable through the Connecting Frame (7) as shown.

Then, attach the Large Pulley (24) that you just removed inside the pulley bracket on the Connecting Frame (7) with the M10 x 50mm Bolt (38), the two M10 Washers (43), and the M10 Locknut (42) that you just removed.

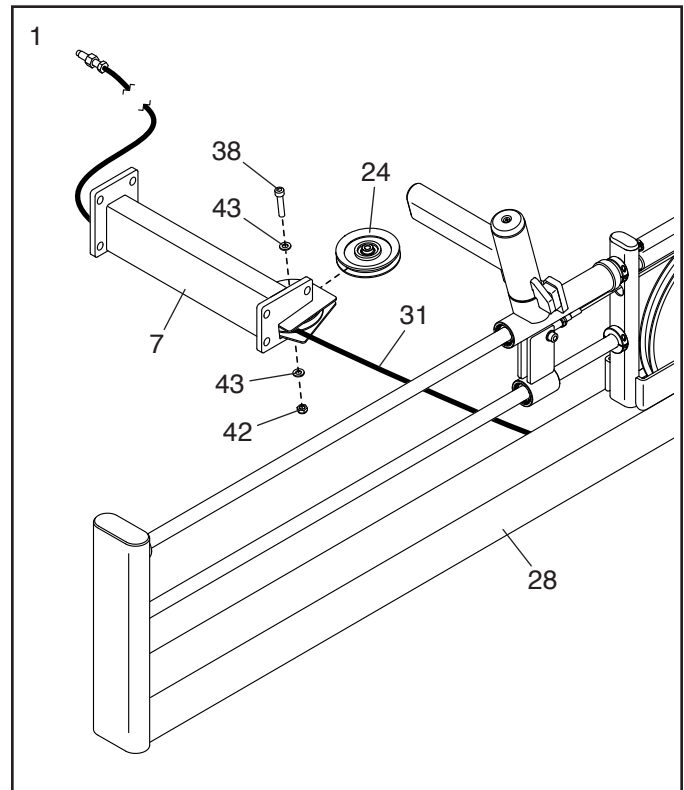

2. Attach the Connecting Frame (7) to the Main Frame (28) with three M10 x 30mm Screws (39) and three M10 Washers (43); **do not tighten the Screws yet.**

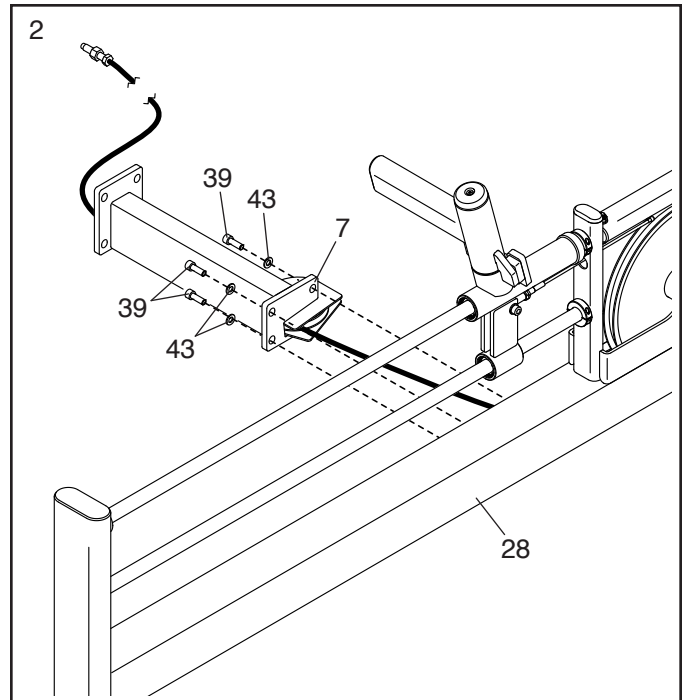

3. Orient the Tower Frame (1) as shown, and set it near the Connecting Frame (7). **Have a second person hold the Tower Frame to prevent it from falling until you complete step 5.**

Lift the Front Cover (5) and remove it from the Tower Frame (1).

**Remove the Rear Cover (6) in the same way.**

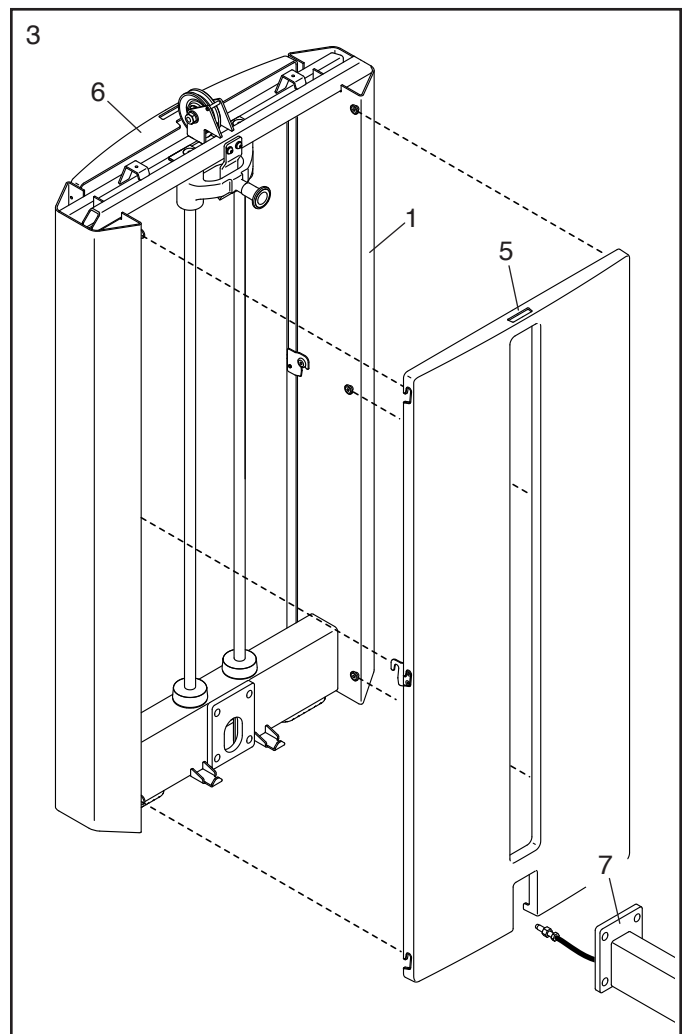

4. Remove the indicated parts (39, 43, 27, 42, 38, 24) from the Tower Frame (1).

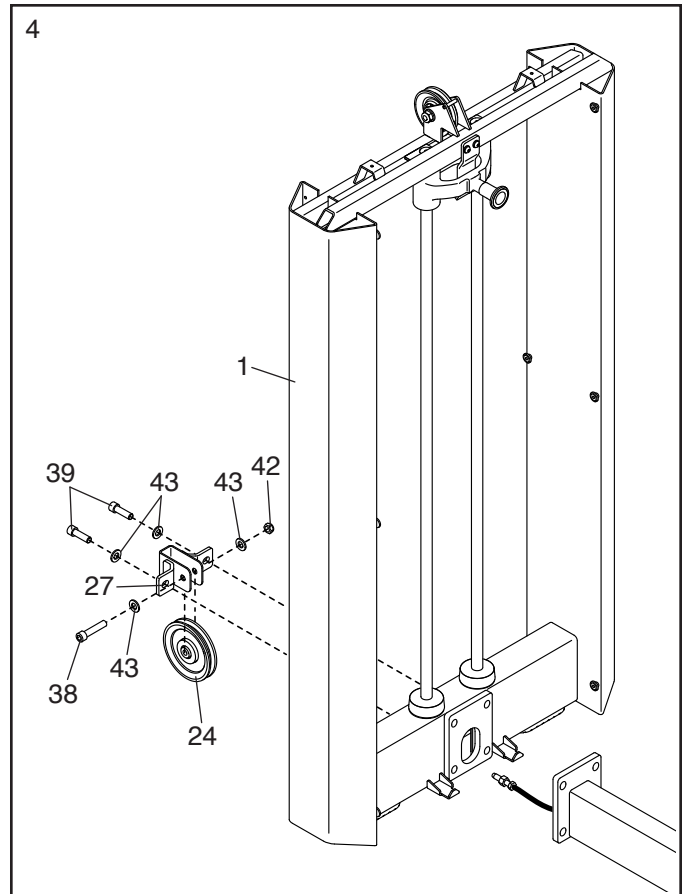

5. Insert the Long Cable (31) through the Tower Frame (1) as shown.

Then, attach the Connecting Frame (7) to the Tower Frame (1) with four M10 x 30mm Screws (39) and four M10 Washers (43); **start all four Screws, and then tighten them.**

**See step 2.** Tighten the three M10 x 30mm Screws (39).

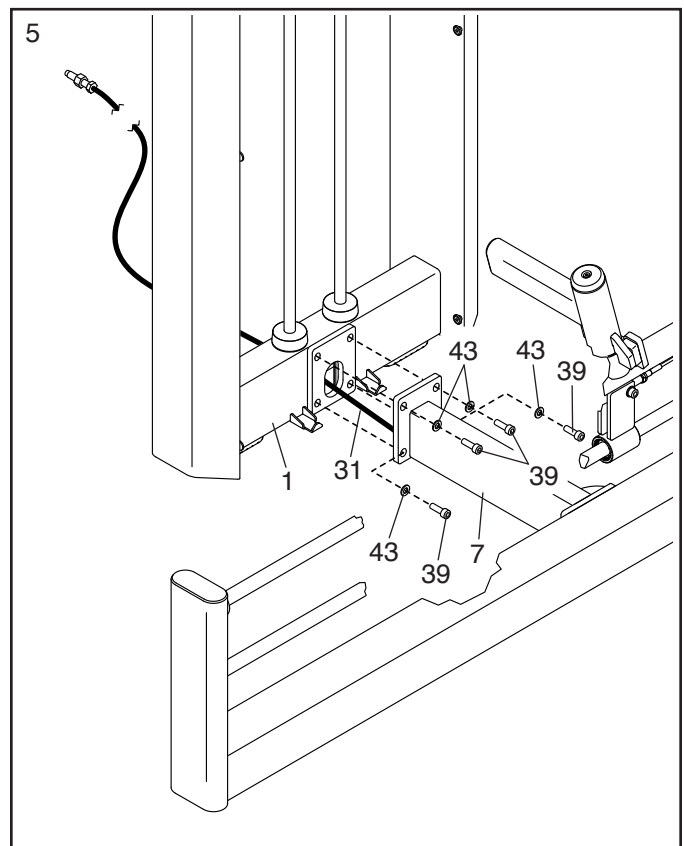

6. Route the Long Cable (31) upward through the Pulley Bracket (27).

Next, attach the Large Pulley (24) that you removed in step 4 inside the Pulley Bracket (27) with the M10 x 50mm Bolt (38), the two M10 Washers (43), and the M10 Locknut (42) that you removed in step 4.

Then, attach the Pulley Bracket (27) to the Tower Frame (1) with the two M10 x 30mm Screws (39) and the two M10 Washers (43) that you removed in step 4.

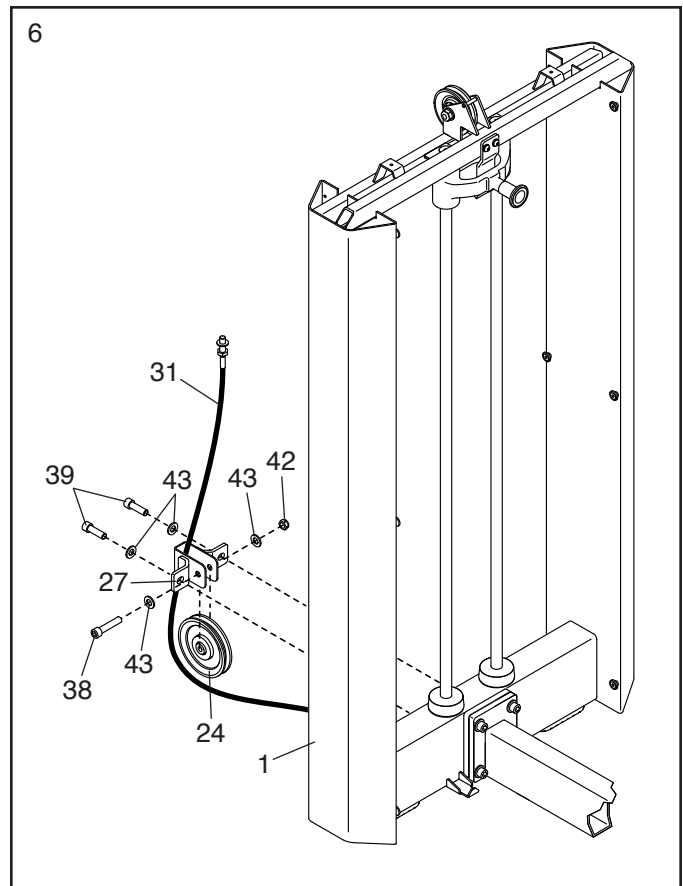

7. Pull the Drop-down Weight Knob (20) and slide the Drop-down Weight (10) downward on the Weight Guides (30).

Next, loosen the two M8 x 20mm Set Screws (19) a few complete turns; **it is not necessary to remove the Set Screws.**

Look under the top of the Tower Frame (1) and remove the two E-clips (73) from the two Weight Guide Bushings (18).

Next, have a second person hold the Weight Guides (30). Lift the Weight Guide Bushings (18) out of the Tower Frame (1).

Then, tip the upper ends of the Weight Guides (30) toward the Connecting Frame (7), and slide the Drop-down Weight (10) upward off the Weight Guides.

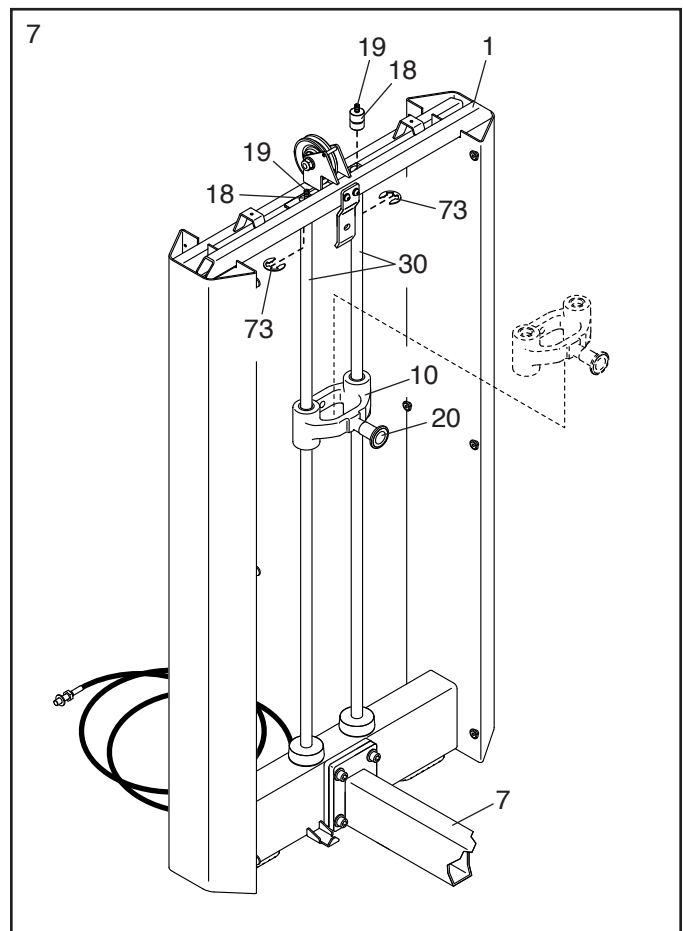

- Look at the decals (A) on the eleven 20-pound Weights (8) and the seven 10-pound Weights (29), and find the decal that has the **largest** number on it. Orient that Weight so that the decal is facing the Connecting Frame (7), and slide the Weight onto the Weight Guides (30).

**Repeat this step with the remaining 20-pound Weights (8) and 10-pound Weights (29).**

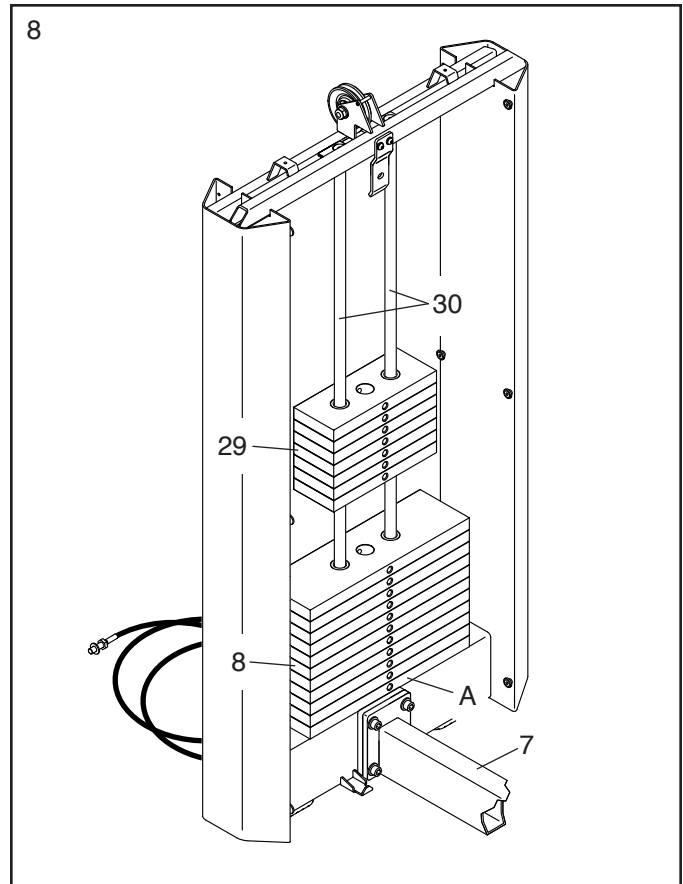

- Orient the Top Weight (9) and the Drop-down Weight (10) as shown; **make sure that the Weight Pin (12) on the Top Weight is on the indicated side.**

Slide the Top Weight (9), the two Upper Weight Bumpers (16), and the Drop-down Weight (10) onto the Weight Guides (30).

Next, insert the two Weight Guide Bushings (18) into the Tower Frame (1), and slide them onto the upper ends of the Weight Guides (30).

Next, attach the two E-clips (73) to the Weight Guide Bushings (18).

Then, tighten the two M8 x 20mm Set Screws (19) into the Weight Guide Bushings (18).

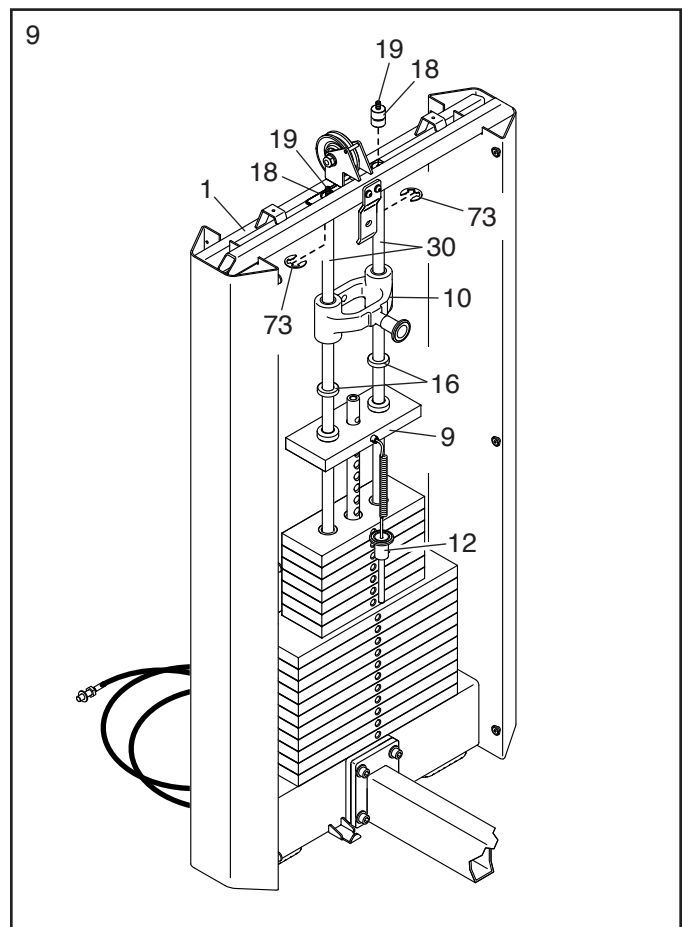

10. Remove the indicated parts (42, 38, 43, 23) from the pulley bracket on the Tower Frame (1).

Next, route the Long Cable (31) through the pulley bracket and downward through the opening in the center of the Tower Frame (1).

Next, attach the Small Pulley (23) that you just removed inside the pulley bracket with the M10 x 50mm Bolt (38), the two M10 Washers (43), and the M10 Locknut (42) that you just removed. **Make sure that the Long Cable (31) is between the Small Pulley and the rod (B) on the pulley bracket.**

**Then, slide the Drop-down Weight (10) upward until the Drop-down Weight Knob (20) snaps into the hole in the Latch Bracket (26). Make sure that the Drop-down Weight Pin (not shown) is engaged in the hole.**

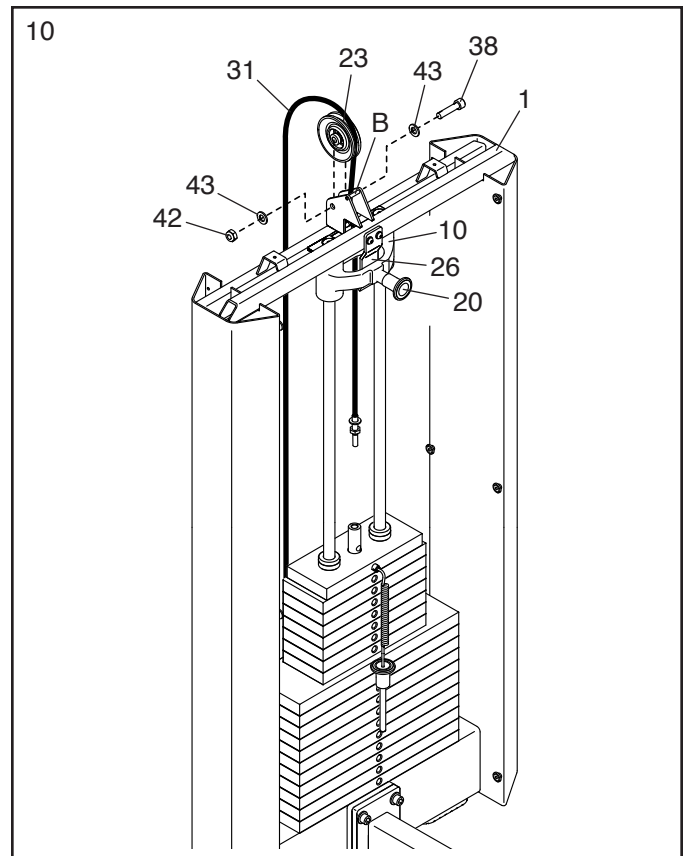

11. Finger tighten the indicated jam nut (C) as far as possible onto the end of the Long Cable (31).

Next, tighten the end of the Long Cable (31) into the Weight Selector (11) until the Top Weight (9) is lifted off the 10-pound Weights (29). Then, loosen the end of the Cable until the Top Weight just rests on the 10-pound Weights.

Then, tighten the jam nut (C) on the Long Cable (31) against the Weight Selector (11).

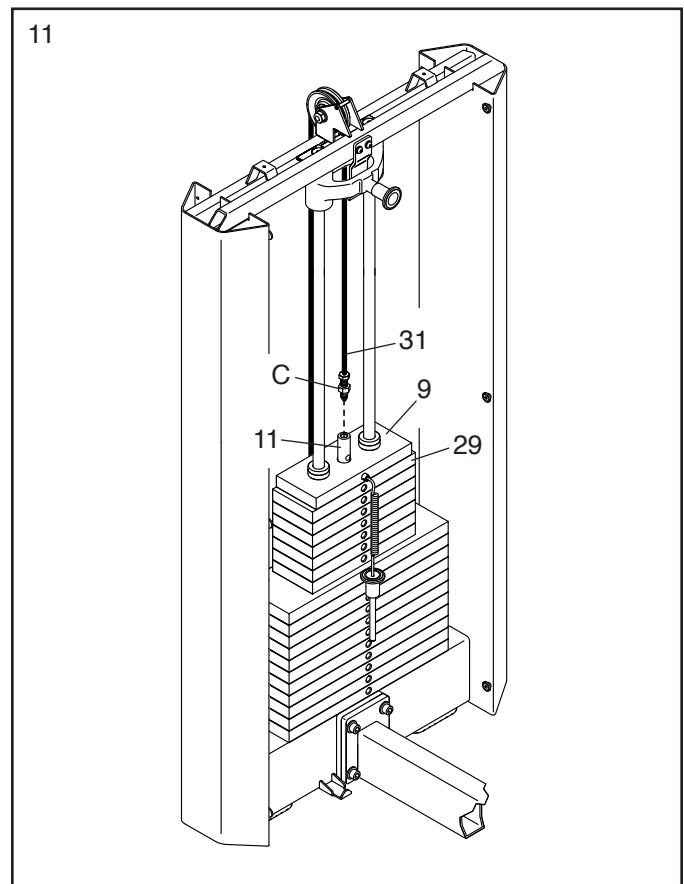

12. Hook the Front Cover (5) onto the indicated six Cover Mounts (32) on the Tower Frame (1).

**Attach the Rear Cover (6) to the Tower Frame (1) in the same way.**

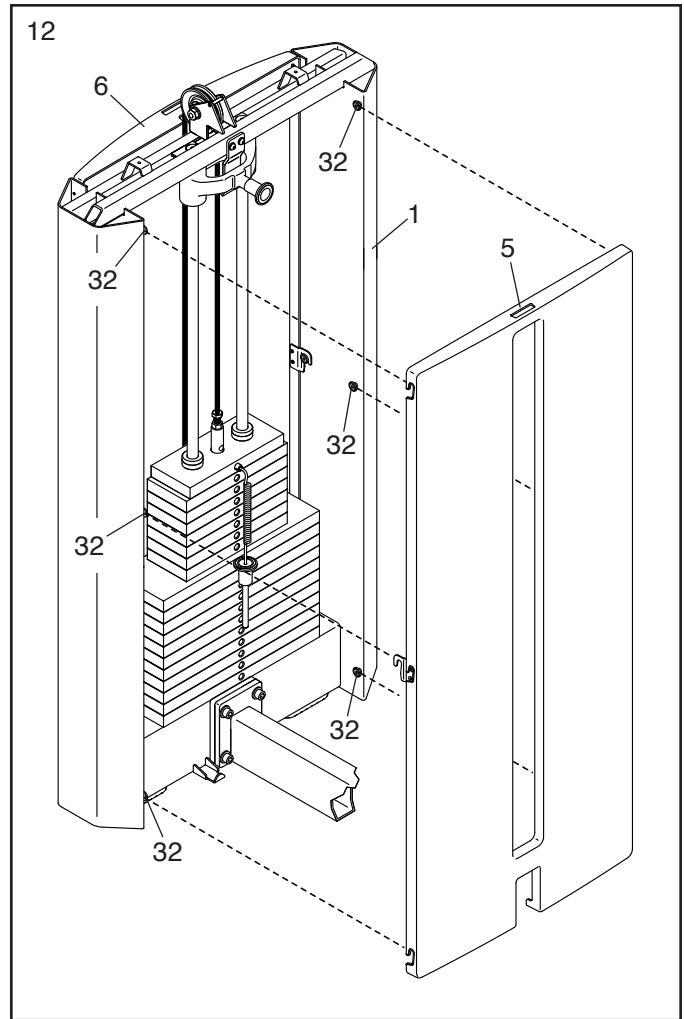

13. Remove the Right and Left Trays (3, 4) from the Tower Cap (2).

Orient the Tower Cap (2) as shown, and attach it to the Tower Frame (1) with two M6 x 12mm Screws (36) and two M6 Washers (46).

Then, insert the Right and Left Trays (3, 4) into the Tower Cap (2).

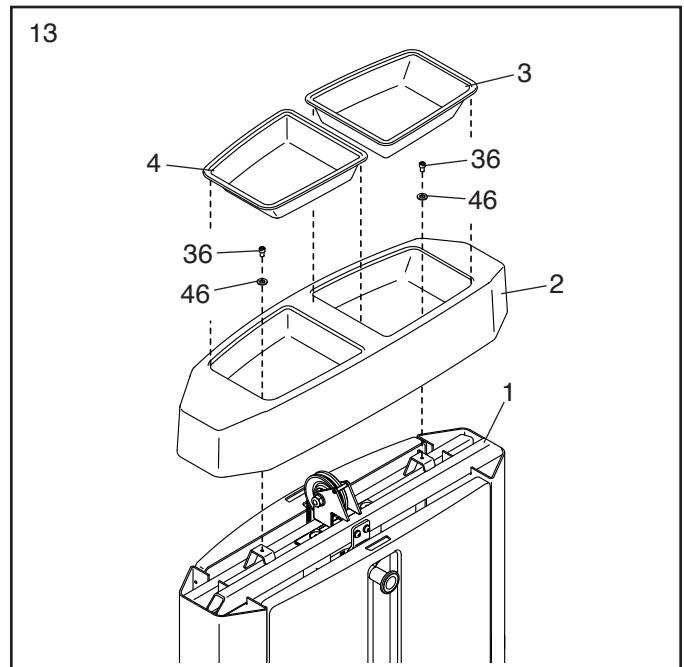

14. Attach the Torso Pad (89) to the Pad Frame (48) with four M8 x 30mm Screws (79) and four M8 Washers (45); **start all four Screws, and then tighten them.**

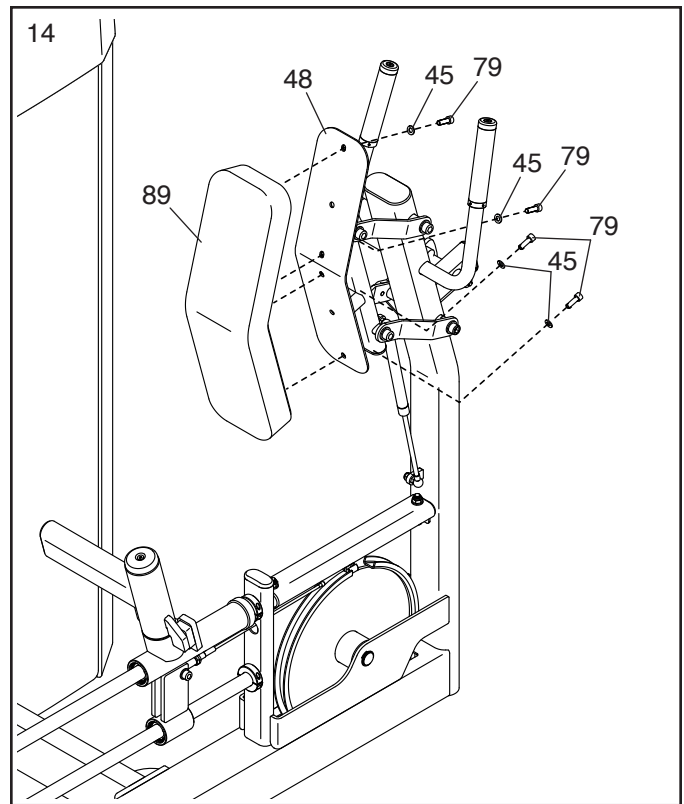

15. **Make sure that all parts of the strength equipment are properly tightened.** To protect the floor or carpet from damage, place a mat under the strength equipment.

# ADJUSTMENT

This section explains how to adjust the strength equipment. **Make sure all that parts are properly tightened each time the strength equipment is used. Replace any worn parts immediately.**

## ADJUSTING THE RESISTANCE

To change the amount of resistance, insert the weight pin (A) into the desired weight (B). **Make sure that the weight pin is fully inserted. Note: To use only the top weight, insert the weight pin into the hole (C) in the weight selector above the top weight.**

To add 5 lbs. (2.25 kg) of resistance, pull the indicated knob (D) and lower the drop-down weight (E) onto the weight stack.

When you are not using the drop-down weight (E), slide it upward until the knob (D) snaps into the hole in the latch bracket (F). Move the drop-down weight upward and downward slightly to make sure that the knob is fully engaged in the hole.

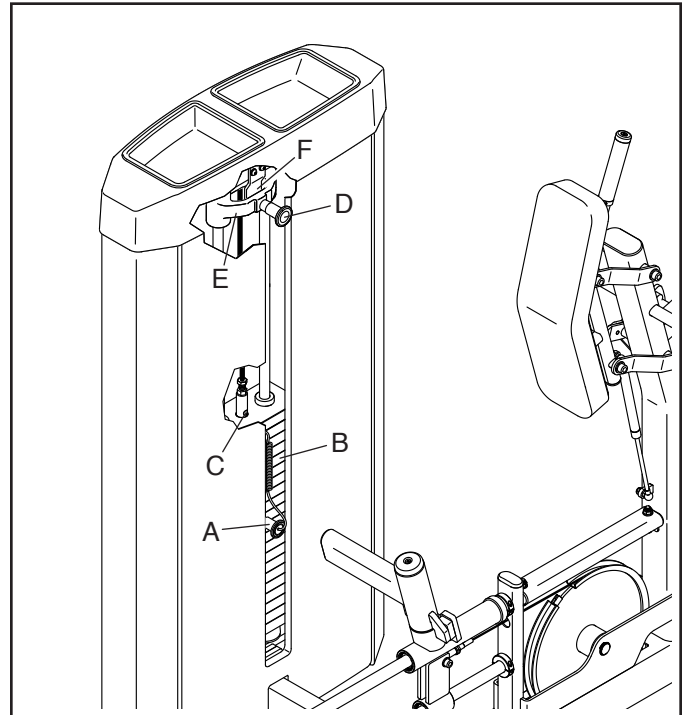

## ADJUSTING THE RESISTANCE ARM

To adjust the resistance arm (G), simply pivot the resistance arm to one side or the other.

## ADJUSTING THE TORSO PAD

To adjust the height of the torso pad (H), pull the adjustment knob (I), move the torso pad upward or downward to the desired position, and then release the adjustment knob into the torso selector (not shown). **Move the torso pad upward and downward slightly to make sure that the adjustment knob is firmly engaged in the torso selector.**

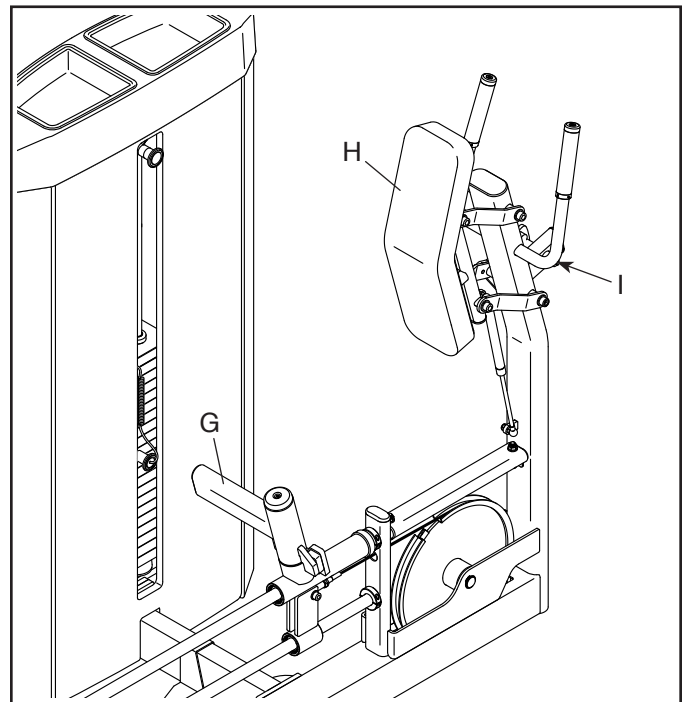

# MAINTENANCE AND TROUBLESHOOTING

For optimal performance of the strength equipment and to reduce the chances of injury to users, you must perform preventive maintenance on a regular basis. Instruct all personnel to perform the procedures described in this section. Personnel must also record and report any accident. To maintain the strength equipment's warranty, use only FREEMOTION parts for repair or replacement. If there are any questions or concerns, see HOW TO CONTACT CUSTOMER CARE on the back cover of this manual.

## DAILY MAINTENANCE

### General Cleaning

Clean the strength equipment using a soft cloth dampened with mild soap and warm water. If necessary, use a soft bristle brush with the cleaning solution.

Then, rinse the strength equipment using a soft cloth dampened with clean water, and thoroughly dry it.

### Difficult Stains

Spray the stain with a non-abrasive household cleaner such as FORMULA 409®, SIMPLE GREEN®, or a similar product. Rub the stained area gently, and then let the cleaning solution sit for a few minutes.

Then, rinse the strength equipment using a soft cloth dampened with clean water, and thoroughly dry it.

If necessary, repeat these steps using a soft bristle brush.

### Optional Method for Difficult Stains

Rub the stained area gently using a soft cloth dampened with rubbing alcohol.

Then, rinse the strength equipment using a soft cloth dampened with clean water, and thoroughly dry it.

**CAUTION:** Follow the directions and the safety precautions of the manufacturer of each cleaning product used. Freemotion Fitness and its vendors cannot be held liable for injuries or damage resulting from the use or misuse of cleaning products. **IMPORTANT:** When using any cleaning product, try it first in an unnoticeable place to ensure that there is no damage to the material. Do not use abrasive cleaners; strong cleaners; or solvents such as lacquer thinner, kerosene, gasoline, or similar liquids. Such substances may scratch the strength equipment, damage plastic parts and decals, or cause other damage.

## WEEKLY MAINTENANCE

### Hardware

Check all nuts, bolts, and screws, and tighten them if necessary. **IMPORTANT:** All cushions have dense plywood supports with tee-nuts that are used to attach the cushions to the strength equipment. Because the tee-nuts are held by the plywood, they will not withstand the torque that standard nuts will. When tightening the bolts or screws securing a cushion, turn them only until they are snug and the cushion does not move or feel loose. Overtightening may strip the tee-nuts from the plywood and make it impossible to remove the cushion in the future. Note: Your strength equipment may not have cushions.

### Cable Inspection

Check the entire length of each cable by slowly performing one repetition on the strength equipment. Inspect the cable on the exterior of the strength equipment and the cable on the interior. Run your fingers along the cable, paying close attention at the bends and attachment points. Watch for the following conditions, which may indicate a worn cable that should be replaced:

- A. a torn or split sheath that exposes the cable
- B. a kinked or severely bent cable
- C. a curled or twisted sheath
- D. a stretched sheath with a thinning cross-section

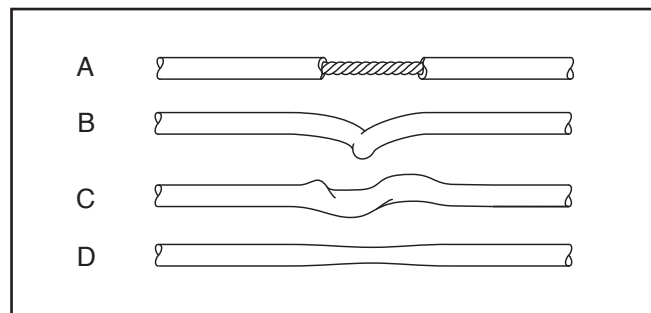

### Cable Adjustment

To determine whether each cable is properly adjusted, slowly raise and lower the top weight by performing one repetition.

If the cable is loose, the top weight will not be lifted immediately when you begin the repetition.

If the cable is too tight, the top weight will not rest on the weight beneath it when you complete the repetition. It may also be difficult to insert the weight pin into the weights.

If the cable is too loose or too tight, loosen the jam nut (A) on the end of the cable (B) attached to the weight selector (C). Next, tighten the end of the cable into the weight selector until the top weight (D) is lifted off the weight beneath it. Next, loosen the end of the cable until the top weight just rests on the weight beneath it. Then, tighten the jam nut against the weight selector.

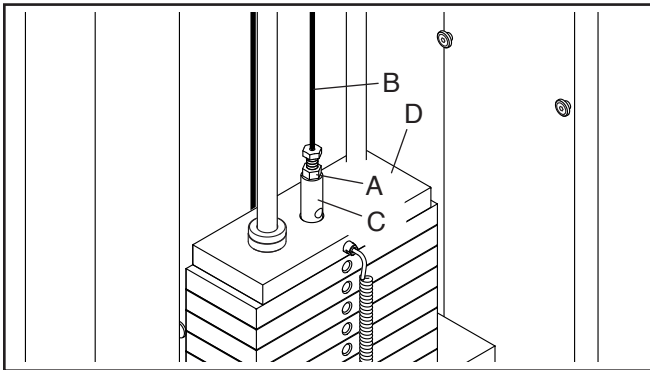

### MONTHLY MAINTENANCE

#### Grips

Check the grips and replace them if needed.

Note: Your strength equipment may not have grips.

#### Weight Guide Lubrication

Clean and lubricate each weight guide by wiping it with a soft cloth containing 10W-40 or 10W-30 lightweight motor oil. Apply only a light coating over the entire length of the weight guide. **Do not use TEFLON<sup>®</sup>-based lubricants.**

# CABLE DIAGRAM

The diagram below shows the correct route of each cable. The numbers in each drawing show the correct route of that cable. Use the diagram to make sure that each cable is correctly routed. **If a cable is not correctly routed, the strength equipment will not function properly and damage may occur.**

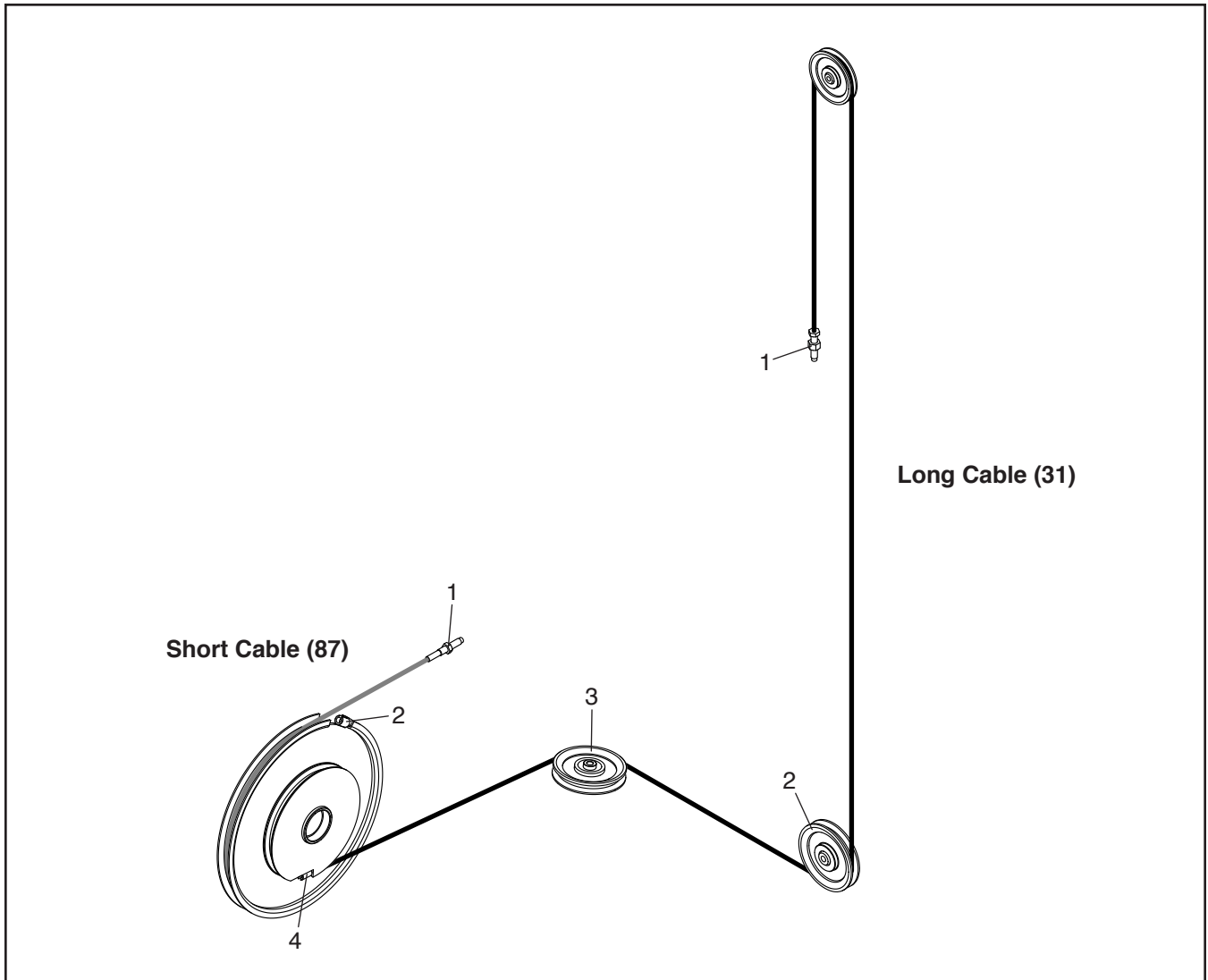

---

# NOTES

---

# NOTES

# PART LIST

Model No. ES820.0 R1019A

Key No.	Qty.	Description	Key No.	Qty.	Description
1	1	Tower Frame	49	1	Carriage Axle
2	1	Tower Cap	50	1	Cam Axle
3	1	Right Tray	51	3	Torso Bracket
4	1	Left Tray	52	1	Torso Selector Bracket
5	1	Front Cover	53	1	Torso Selector
6	1	Rear Cover	54	2	Rail
7	1	Connecting Frame	55	1	Adjustment Pin
8	11	20-pound Weight	56	4	Rail Clamp
9	1	Top Weight	57	2	Handle Collar
10	1	Drop-down Weight	58	2	Handle Cap
11	1	Weight Selector	59	1	Barrel Nut
12	1	Weight Pin	60	1	Adjustment Spring
13	2	Lower Weight Bumper	61	1	Bearing Cover
14	2	Weight Guide Cap	62	1	Adjustment Knob
15	1	Roll Pin	63	1	Carriage Bumper
16	2	Upper Weight Bumper	64	2	Handgrip
17	4	Copper Bushing	65	1	Frame Bumper
18	2	Weight Guide Bushing	66	4	Cover Bracket
19	2	M8 x 20mm Set Screw	67	2	Resistance Arm Pad
20	1	Drop-down Weight Knob	68	1	Small Oval Cap
21	1	Drop-down Weight Spring	69	3	Plastic Washer
22	1	Drop-down Weight Pin	70	2	Selector Bumper
23	1	Small Pulley	71	1	Resistance Cylinder
24	2	Large Pulley	72	1	Ball Joint
25	4	Foot	73	2	E-clip
26	1	Latch Bracket	74	1	Anchor Strap
27	1	Pulley Bracket	75	8	M5 x 10mm Screw
28	1	Main Frame	76	3	C-clip
29	7	10-pound Weight	77	2	M12 x 125mm Bolt
30	2	Weight Guide	78	2	M12 x 175mm Bolt
31	1	Long Cable	79	4	M8 x 30mm Screw
32	12	Cover Mount	80	7	M8 x 16mm Screw
33	3	Snap Ring	81	8	M6 x 16mm Screw
34	13	M6 x 16mm Flat Head Screw	82	2	M6 x 20mm Screw
35	2	M6 x 16mm Screw	83	7	M12 Washer
36	2	M6 x 12mm Screw	84	3	M12 Locknut
37	1	Slide Carriage	85	2	M8 Locknut
38	6	M10 x 50mm Bolt	86	4	M4 x 3mm Set Screw
39	10	M10 x 30mm Screw	87	1	Short Cable
40	1	Resistance Arm	88	4	Bearing
41	1	Cam	89	1	Torso Pad
42	6	M10 Locknut	90	1	Pad Frame Cap
43	21	M10 Washer	91	2	Large Oval Cap
44	8	M8 x 25mm Screw	92	3	Linear Bearing
45	17	M8 Washer	93	8	Torso Bushing
46	4	M6 Washer	94	2	M4 x 5mm Set Screw
47	1	Cam Bar	*	—	Owner's Manual
48	1	Pad Frame			

Note: Specifications are subject to change without notice. For information about ordering replacement parts, see the back cover of this manual. \*These parts are not illustrated.

# EXPLODED DRAWING A

Model No. ES820.0 R1019A

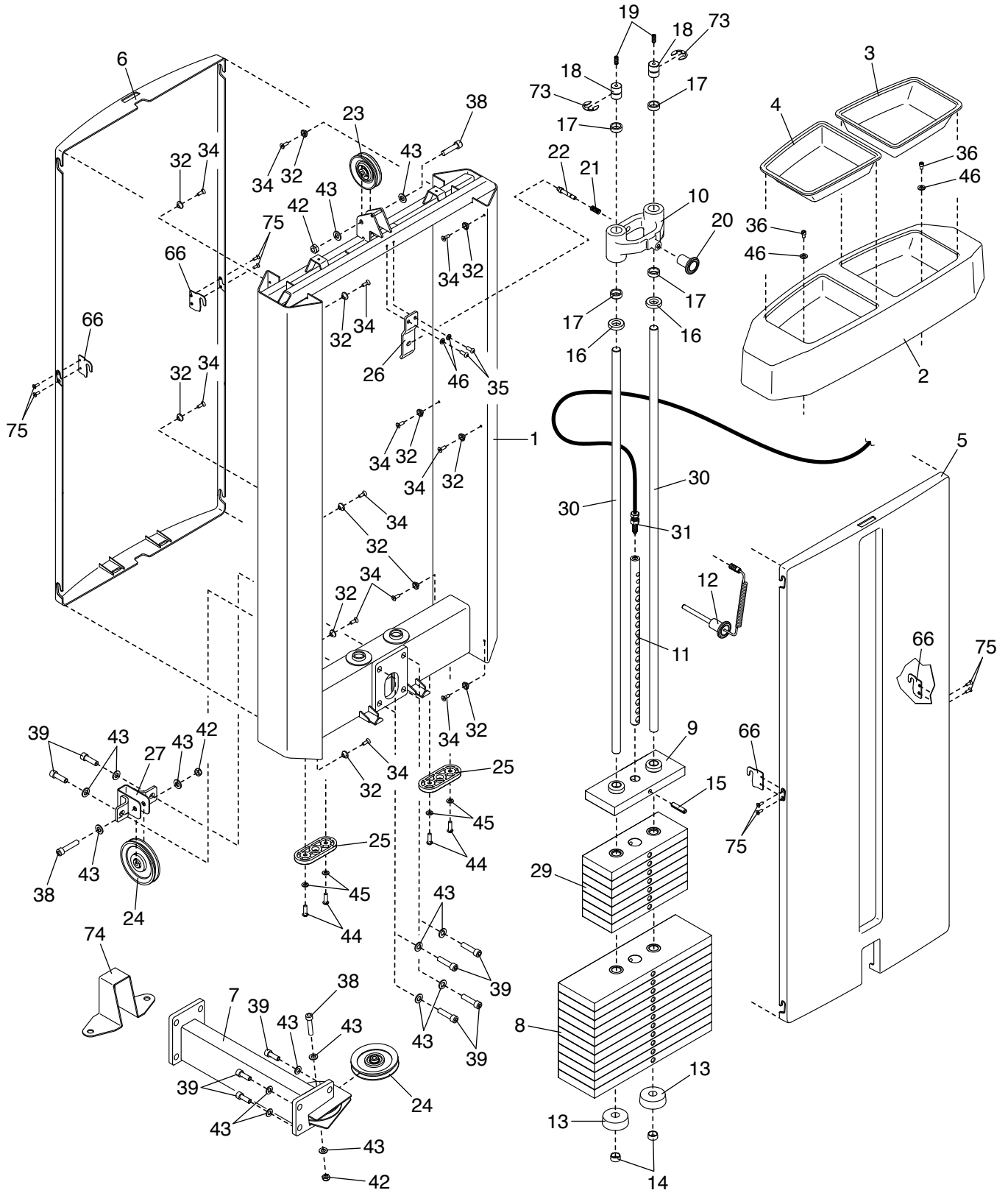

# EXPLODED DRAWING B

Model No. ES820.0 R1019A

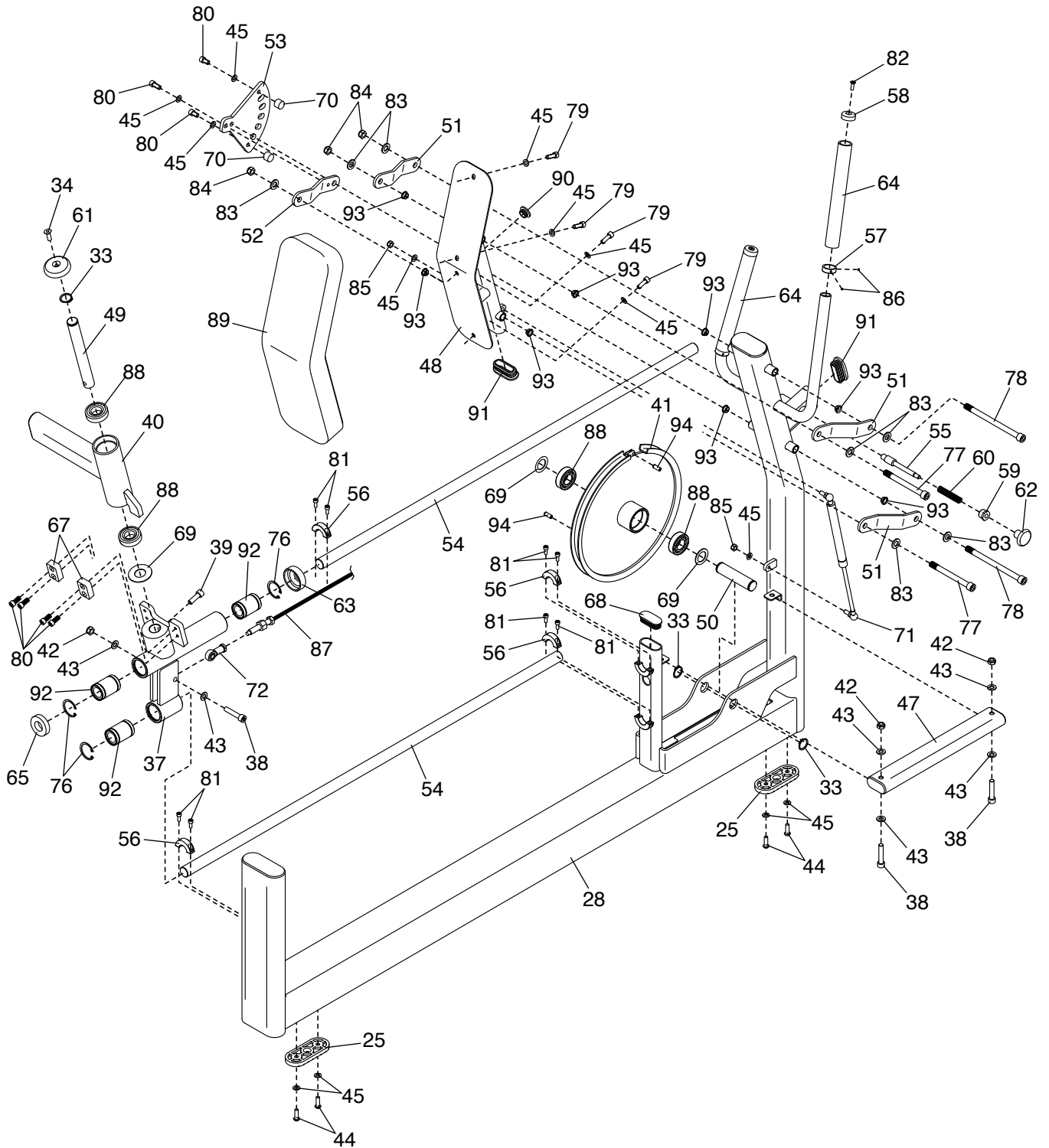

---

# HOW TO CONTACT CUSTOMER CARE

If you have questions after reading this manual, or if parts are damaged or missing, please contact Customer Care at one of the phone numbers or addresses listed below. **Please note the model number, serial number, and name of the product (see the front cover of this manual) before contacting Customer Care. If you are ordering replacement parts, please also note the key number and description of each part (see the PART LIST and the EXPLODED DRAWING near the end of this manual).**

## In the United States

Call: 1-800-201-2109, Mon.–Fri. 6 a.m.–6 p.m. MT

Email: [customercare@freemotionfitness.com](mailto:customercare@freemotionfitness.com)

Write:

Freemotion Fitness  
1500 South 1000 West  
Logan, UT 84321-9813  
United States

## Outside the United States

Call: 001-800-527-5417 or 001-435-786-3521,

Mon.–Fri. 6 a.m.–3 p.m. USA Mountain Time

Email: [intlcustomercare@freemotionfitness.com](mailto:intlcustomercare@freemotionfitness.com)

---

# LIMITED WARRANTY

## WARRANTY PERIODS AND COVERAGE

Freemotion Fitness warrants this product to be free from defects in workmanship and material under normal use and service conditions. Parts and labor are warranted for one (1) year, unless otherwise specified on the invoice.

The warranty period commences on the invoice date of purchase. Any parts repaired or replaced during this warranty period will be warranted for the remainder of the original warranty period.

## CONDITIONS AND LIMITATIONS

The following will void the warranty on this product:

1. This warranty applies only to the original owner and is non-transferable.
2. The labor warranty applies only to products sold in the US and Canada. Contact your authorized Freemotion Fitness dealer for details on labor coverage in your country.
3. Any misuse, abuse, or improper service.
4. Users in excess of the maximum user weight listed in this manual. Note: This product may not have a maximum user weight.
5. Damage caused by moving the product or improper storage including moving or storing the product on its side.
6. Use or storage of the product outdoors or in high-humidity environments including spa and pool areas.
7. Damage caused by improper wiring or insufficient electrical current. Note: This product may not have wiring.

This warranty shall not apply to the following:

1. Cosmetic items including grips, decals, and labels.

2. Pick-up and delivery or freight charges involved with a repair.
3. Any problem as a result of improper assembly or delivery.

## WHAT TO DO IF SERVICE IS REQUIRED

Freemotion Fitness warranty service may be obtained by contacting the authorized dealer from which you purchased this product. Make sure to retain your original invoice and serial number information. If this product experiences a failure under the warranty terms set forth, Freemotion Fitness shall provide at their option either repair, replacement, or refund of the purchase price. Freemotion Fitness compensates service providers for warranty trips within their service area. You may be charged additionally for service calls beyond this service area.

Freemotion Fitness is not responsible or liable for indirect, special, or consequential damages arising out of or in connection with the use or performance of the product; damages with respect to any economic loss, loss of property, loss of revenues or profits, loss of enjoyment or use, or cost of removal or installation; or other consequential damages. Some regions do not allow the exclusion or limitation of consequential damages. Accordingly, the above limitation may not apply to you. This warranty gives you specific rights, and you may have other rights that vary from region to region.

## TO CONTACT FREEMOTION FITNESS

See HOW TO CONTACT CUSTOMER CARE above.