

Queen Bed

Assembly Instructions

WII-0419

1 Assembled View

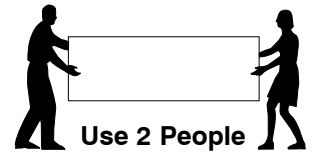
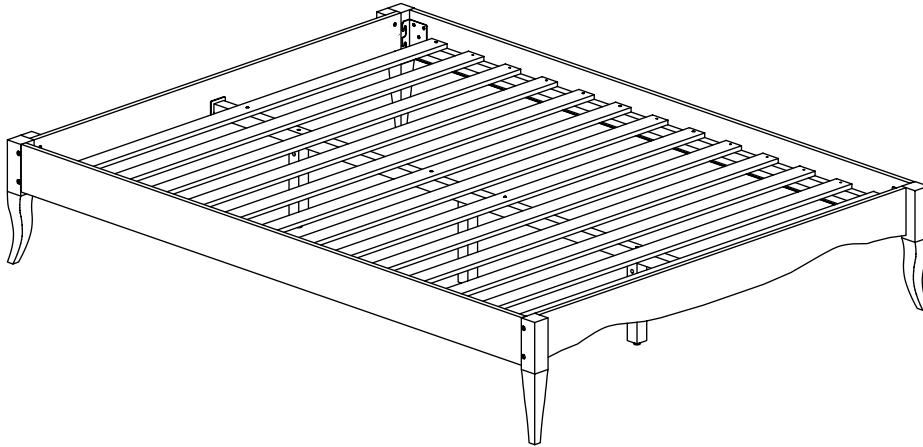

Note: Do not assemble using power tools. This can cause the bolts to be overtightened

2 Parts List



A Headboard Panel x 1



B Footboard Panel x 1



E Support Leg x 3



F Post (Left hand) x 2



G Post (Right hand) x 2

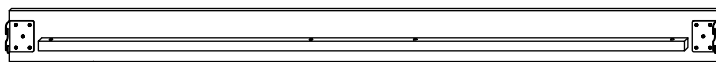

C Side Rail x 2



D Long Support x 1

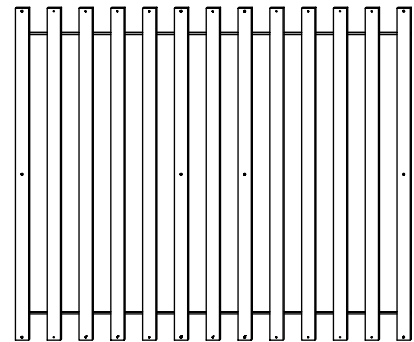

H Set of Bed Slats x 1

3 Hardware List



1 M4 Allen Key x 1

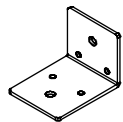

2 Center Rail Bracket x 2

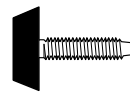

3 Adjustable Foot x 3

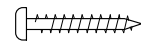

4 Wood Screw (M4 x 32mm) x 22

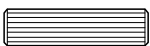

5 Wood Dowel (10 x 40mm) x 4



6 Barrel Nut x 11



7 Spring Washer x 14



8 Flat Washer x 14



9 M6 x 15mm JCB x 4



10 M6 x 20mm JCB x 8



11 M6 x 40mm JCB x 18



12 M6 x 90mm JCB x 11

97132 Queen Bed

Assembly Instructions

WII-0419

- 4** Assembled the Support Leg (E) to the Long Support (D).

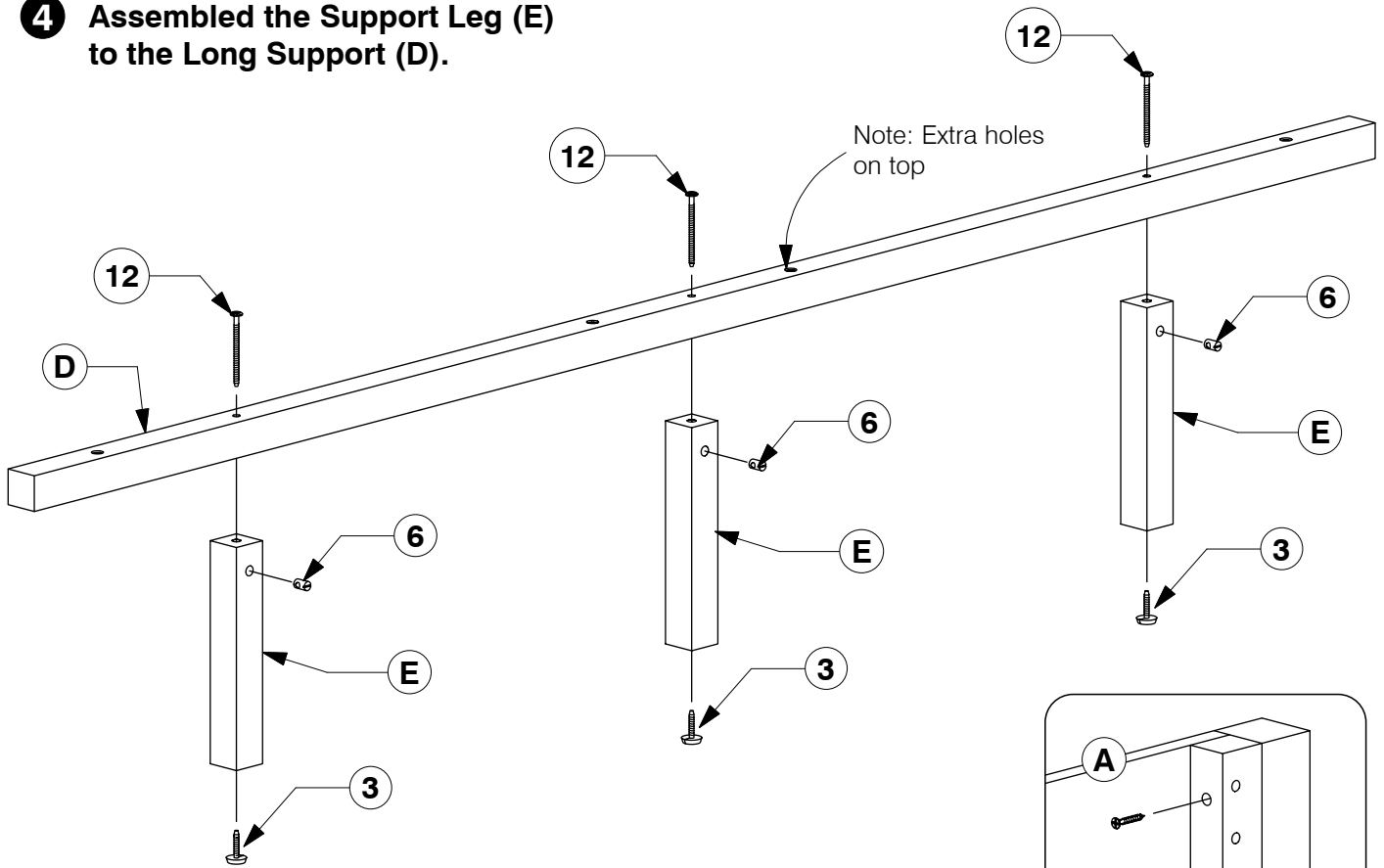

- 5** Fit the Center Rail Bracket to the Headboard Panel (A). Assemble the Headboard Panel (A) to Post (F/G), using Wood Screw 32mm (4).

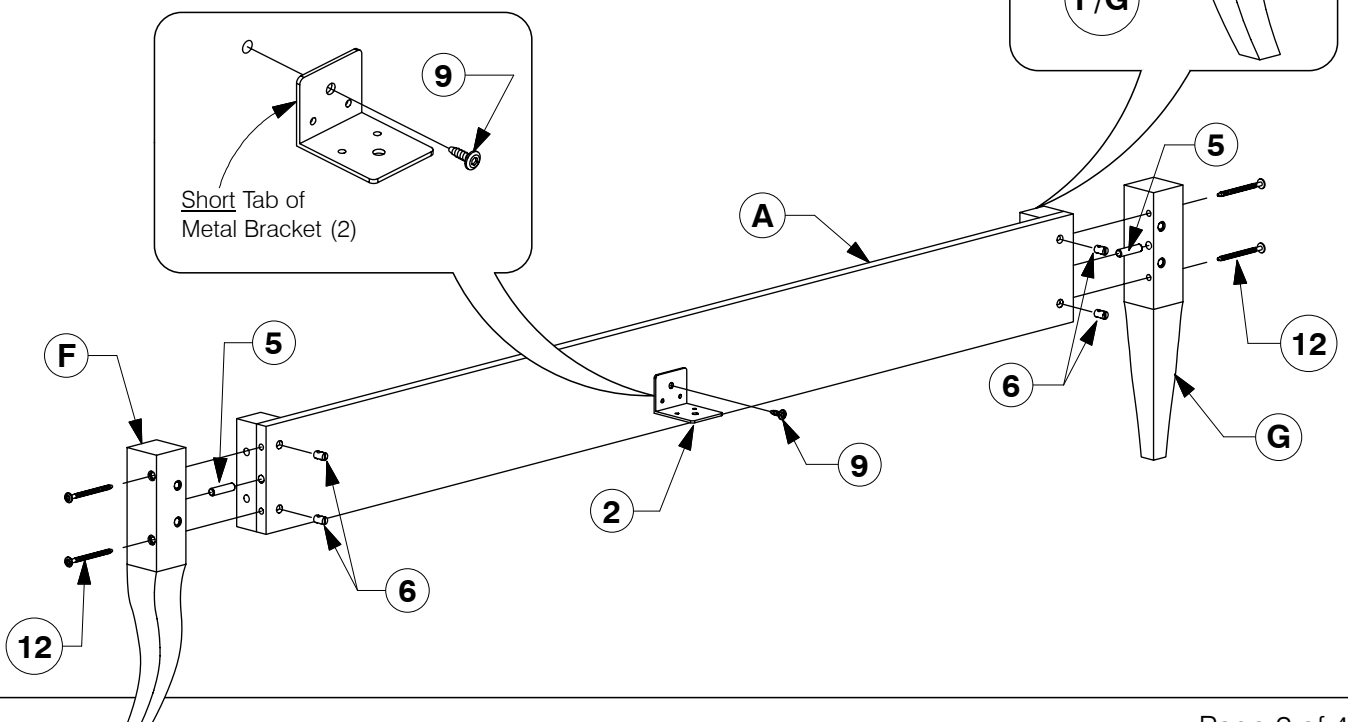

97132 Queen Bed

Assembly Instructions

W11-0419

- 6** Fit the Center Rail Bracket to the Footboard Panel (B).

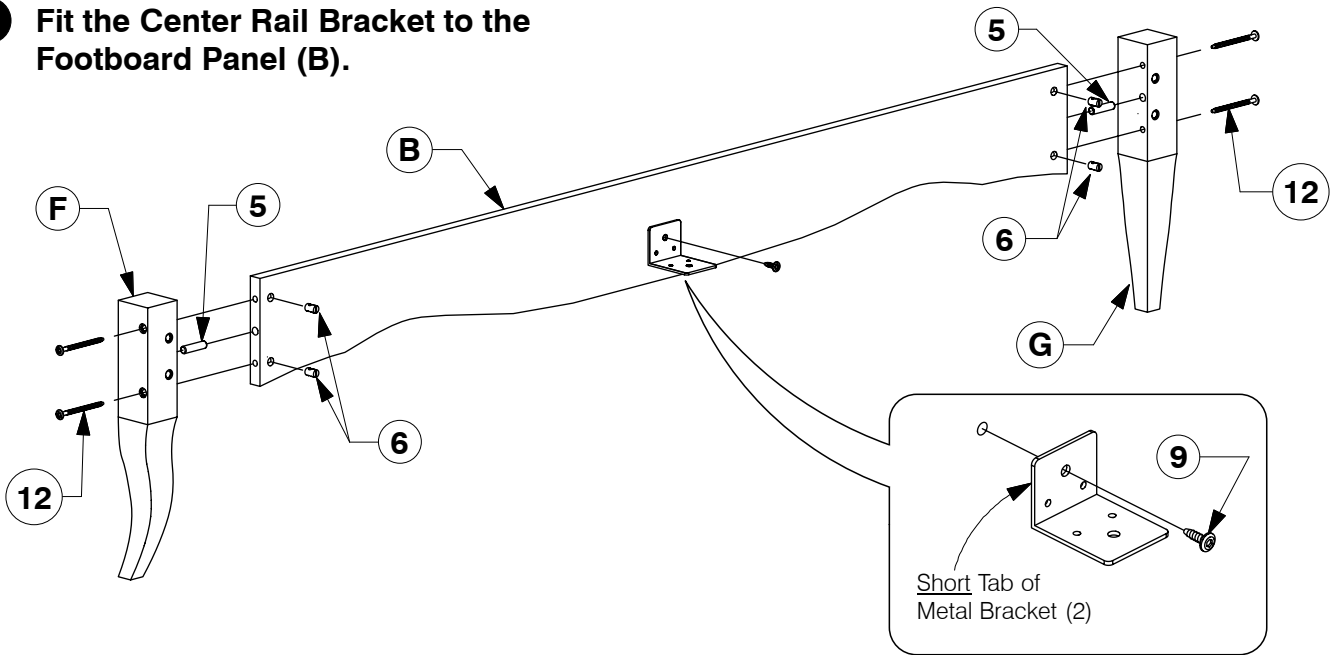

- 7** Assemble the Side Rail (C) to the Headboard and Footboard Panel (A & B).

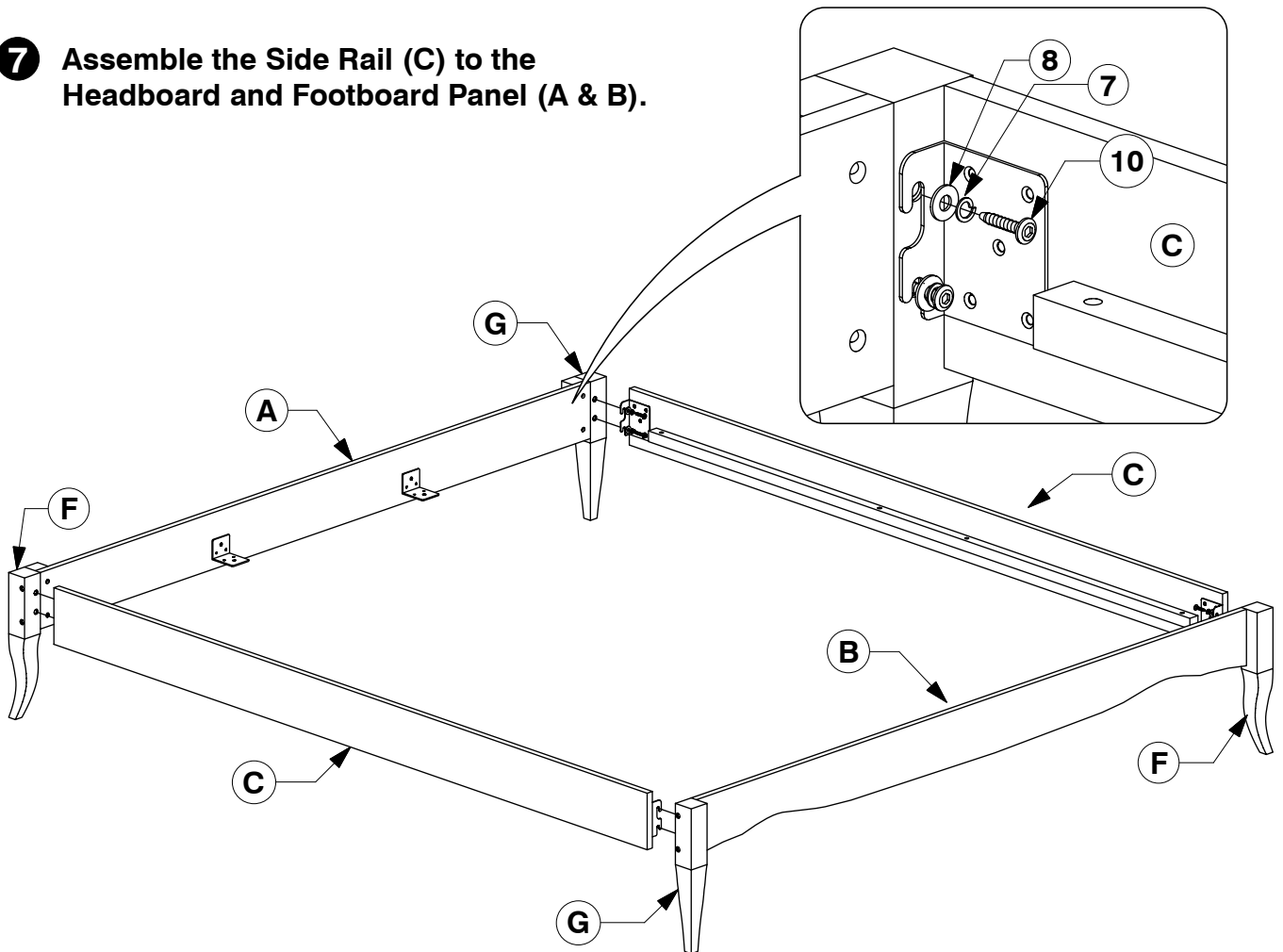

97132 Queen Bed

Assembly Instructions

W11-0419

- 8 Bolt the Long Support (D) to the Center Rail Brackets (2) on the Headboard and Footboard Panel (A & B).**

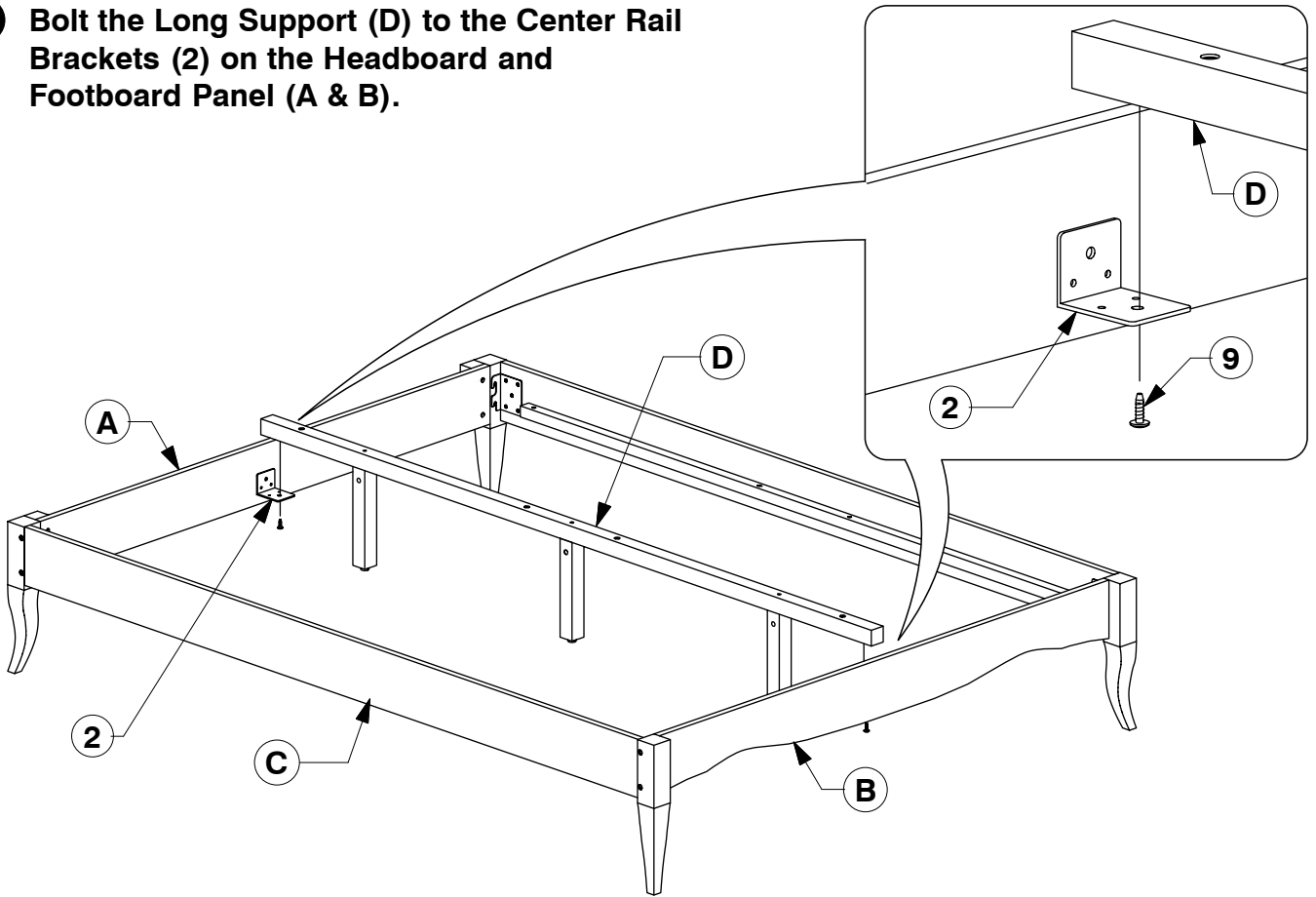

- 9 Bolt & screw the Bed Slats (H) to the Side Rail (C).**

