

ASSEMBLY INSTRUCTIONS

WESTON CHIFFEROBE

Model #12145

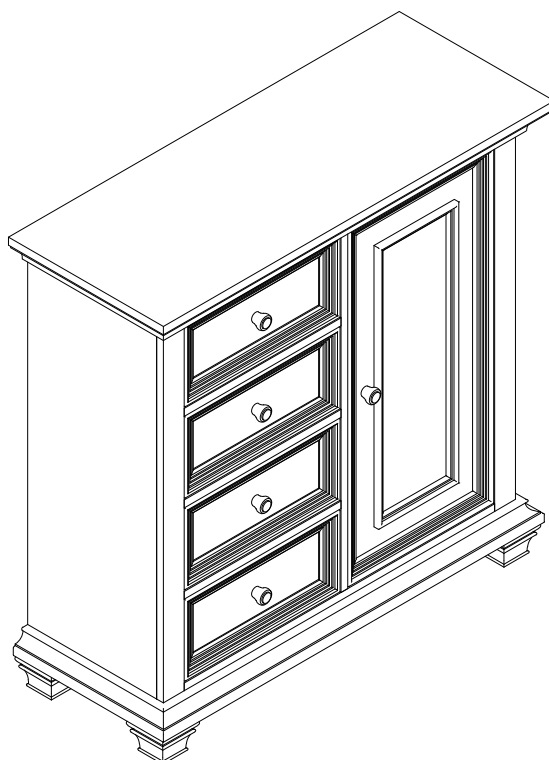

Thank you for your purchase!

Remove all parts and hardware from the box and lay on a carpeted or scratch -free work surface.
Do not dispose of any contents until assembly is completed.

TOOLS REQUIRED:

ALLEN KEY (Included)



PARTS ENCLOSED IN CARTON

A. Dresser (1 pc)

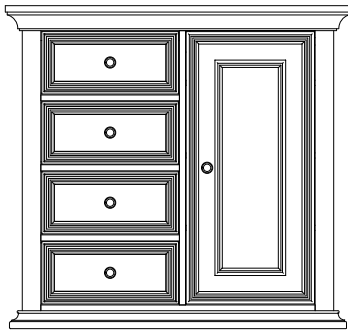

B. Front foot (2 pcs)

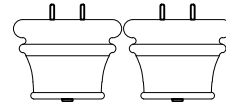

C. Back foot (2 pcs)

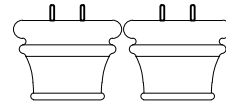

HARDWARE

(D) Allen Bolt 3-1/2" (90 mm) (4 pcs)

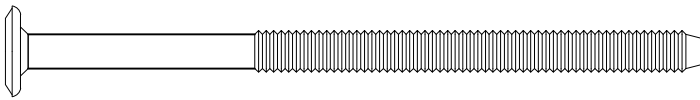

(E) Spring washer (4 pcs)



(F) Allen key (1 pc) (length may vary)



Do not fully tighten all bolts until all parts are in place.
(please add an extra 1/2 revolution to the bolts when using spring washer after tightening)

STEP 1 "ASSEMBLY OF CHIFFEROBE"

THIS STEP REQUIRES : (F) Allen key (1 pc) (length may vary)

(E) Spring washer (4 pcs)

A. Chifferobe (1 pc)

B. Front foot (2 pcs)

C. Back foot (2 pcs)

(D) Allen Bolt 3-1/2" (90 mm) (4 pcs)

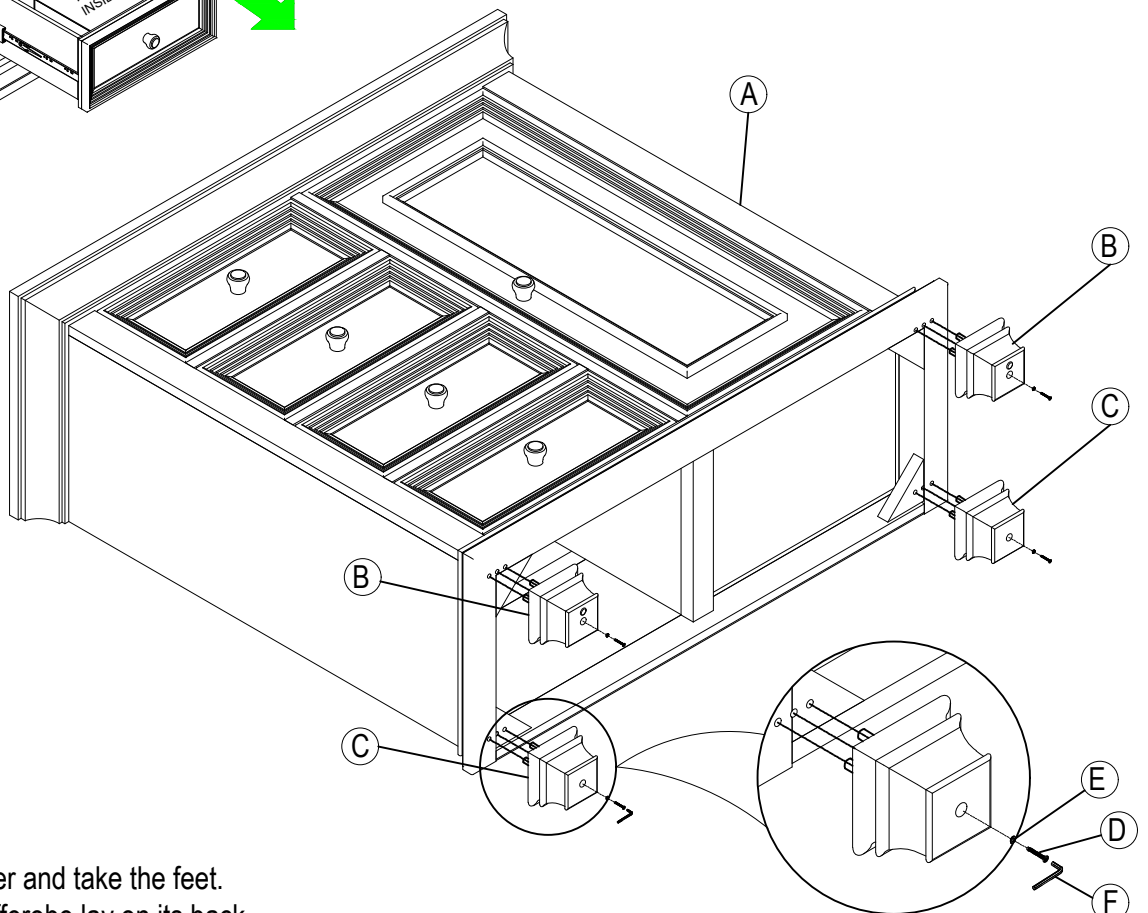
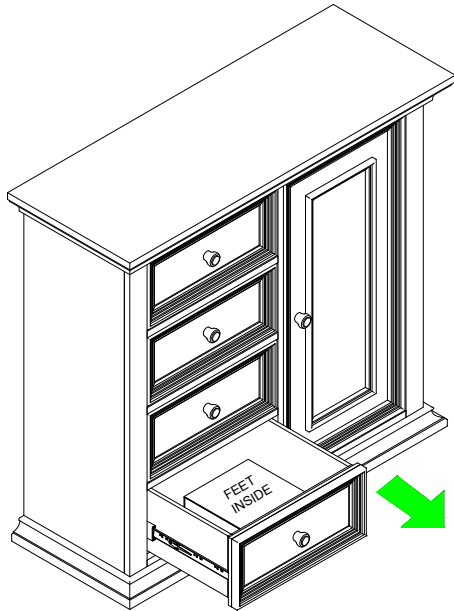
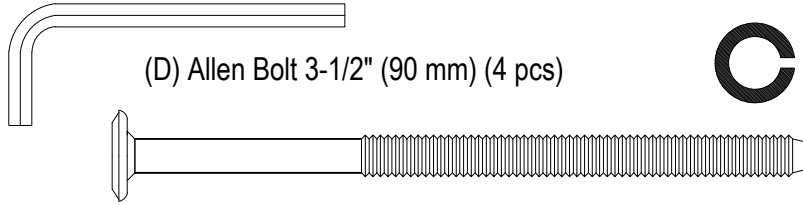

STEP 1:

- Open a drawer and take the feet.
- Place the chifferobe lay on its back.
- Attach Front feet (B) and Back feet (C) to chifferobe bottom frame through pre-assembled dowels.
- Secure feet by using Allen bolt (D), Spring washer (E). Tighten all bolt with Allen key (F).
- Flip back the chifferobe.

STEP 2 "SHELVES ADJUSTMENT"

The product is ready for use after removing all packing material. If you want to move the shelves up or down follow these steps:

1. Before removing the shelves, unscrew and remove the screws, which are attached to the shelf pegs underneath the shelves, with a screw driver.
2. Determine the desired height for the shelves using the corresponding pre-drilled holes located on the inside of the cabinet.
3. Insert the shelf pegs into the pre-drilled holes until fully secure. Place the shelves onto the shelf pegs, making sure the shelf is stable. Reinsert and tighten the screw back into the shelves by inserting the screw through the pre-drilled hole of the shelf peg and into the shelf. See illustration.
4. Adjust leg leveler to accommodate for uneven floor. See illustration. Complete as shown in FIG 1.

TOOLS REQUIRED:

SCREW DRIVER (Not Included)

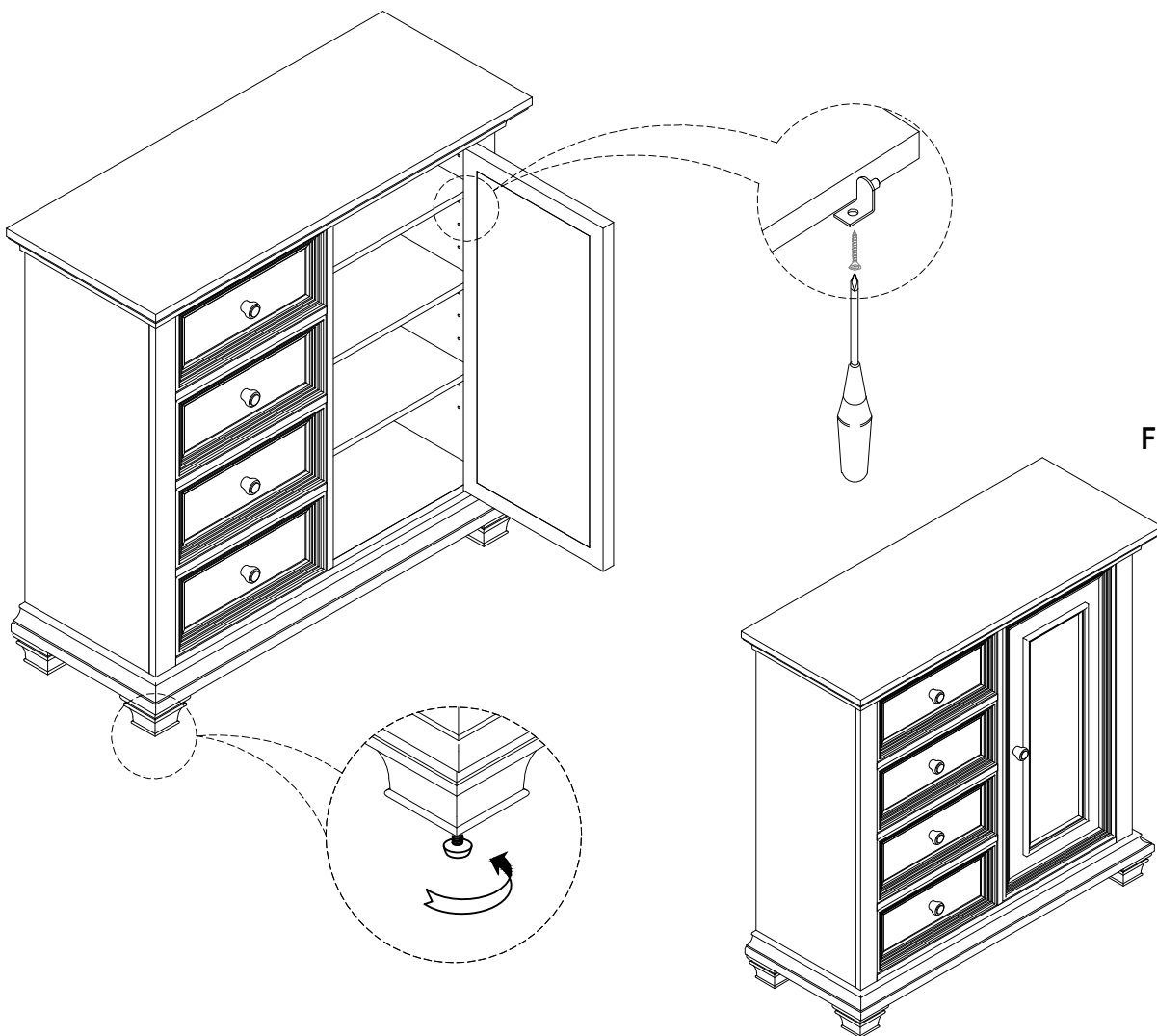
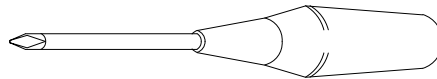

FIG.1.