

PERFORMANCE DATA NO LOAD & NO DOOR OPENINGS AT 37°/0° CONTROL SETTING		
Type A with Run / Start Capacitor	65°F (18°C) Ambient	90°F (32°C) Ambient
Operating Time	90 to 100%	100%
Freezer Temperature	-5° to 2°F (-20° to -17°C)	-1° to 3°F (-18° to -16°C)
Refrigerator Temperature	34° to 39°F (1° to 4°C)	34° to 39°F (1° to 4°C)
Low Side Pressure	-2 to 6 psig (-14 to 41 kPa)	-2 to 6 psig (-14 to 41 kPa)
High Side Pressure (last 1/3 cycle)	85 to 105 psig (586 to 724 kPa)	120 to 135 psig (827 to 931 kPa)
Wattage (last 1/3 cycle)	30 to 50	50 to 70
Amps (running)	.4 to .8	.7 to .9
Base Voltage	115 vac (127 vac max)	

DEFROST SPECIFICATIONS					
Cabinet Size: 27' & 28' SD, 22' CD	Thermal Cutout		Heater		Defrost Heater Termination
	Cut-in	Cut-out	Watts	Ohms	Cut-out
	110°F (43.3°C)	135°F (57.2°C)	500	26.5	48°F (8°C)

CONDENSER FAN MOTOR		
Watts	RPM	Amps
3.1	1100 CW Opposite Shaft	0.03 Running

FREEZER ICE MAKER SPECIFICATIONS	
Electrical	115 vac (127 vac max)
Thermostat	Opens at 48°F (9°C), Closes at 15° F (-9°C)
Heater Voltage	115 vac

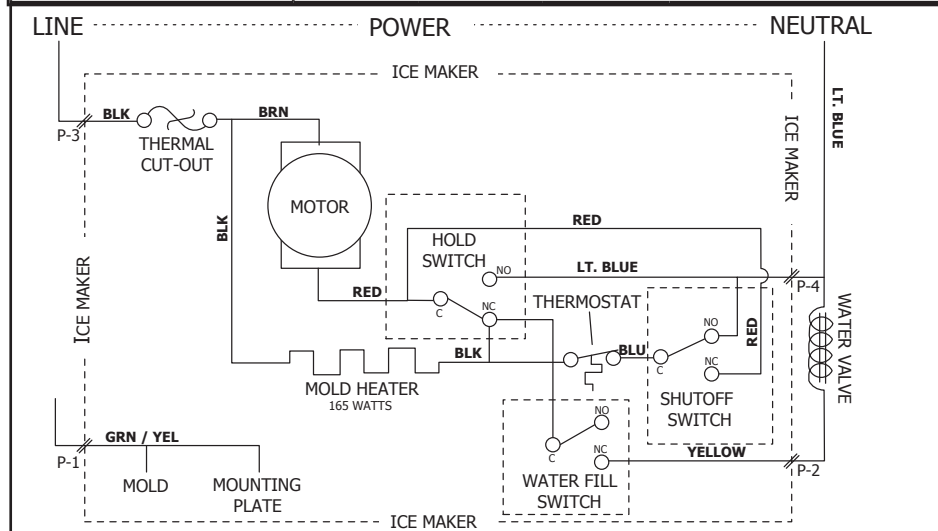

**CAUTION**  
All electrical parts and wiring must be shielded from torch flame. DO NOT allow torch to touch insulation; it will char at 200°F and flash ignite (burn) at 500°F. Excessive heat will distort the plastic liner.

### FREEZER ICE MAKER INFORMATION

(Where Applicable)

**Test Cycling:** Remove cover by inserting screwdriver in notch at bottom and prying cover from housing. Use screwdriver to rotate motor gear counterclockwise until holding switch circuit is completed. All components of ice maker should function to complete the cycle.

**Water Fill Volume:** The water fill adjustment screw will change the fill time. One full turn is equal to 20cc (.68 oz.). The correct fill is 102 to 130cc (3.4 to 4.3 oz.). When a water valve is replaced, the fill volume must be checked.

# SERVICE DATA SHEET

## A06031201

### FREEZER ICE MAKER - AUTOMATIC DEFROST

#### BOTTOM FREEZER - R134a

**IMPORTANT: PLEASE RETURN THIS SHEET TO ITS ORIGINAL LOCATION.**

ERROR CODES			SPECIAL MODES				
Display	Interpretation		Mode	Display		Activate	Deactivate
FZ	FF			FZ	FF	(Press for up to 10 sec. simultaneously)	
--	OP	Open FF Cavity Thermistor	Manual Defrost	d	F	FF + and FF -	Same to deactivate
OP	--	Open FZ Cavity Thermistor	Demo / Show-room	77	77	FZ + and FF -	Unplug to deactivate
--	SH	Shorted FZ Cavity Thermistor	Sabbath	Sb	Sb	FZ - and FF +	Same to deactivate
SH	--	Shorted FZ Thermistor	System Diagnostic	Blank UI display, no LEDs illuminated		FZ + and FZ -	Press and hold FF + to deactivate
SY	CF	UI to Main Board communication failure; on start up	Current Air Temps	FZ Temp	FF Temp	Default Settings and Temp Mode Buttons	Automatically after 10 seconds
SY	CE	UI to Main Board communication error; after a period of operation	<b>Notes:</b> • Always check for pin back-outs, pinched or damaged wires before replacing components. • Determine whether failure is caused by the component, main control board or wiring. <b>Contact TID before replacing main control board.</b> • Refer to Service Manual for additional information.				
SY	EF	Freezer Evaporator Fan Failure					

### VCC COMPRESSOR MOTOR RESISTANCE CHECK

Check resistance between terminals 1 and 2, 2 and 3, 3 and 1. If all resistances are equal, compressor is operative.

### Service Mode For Perfect Temp™ Drawer

<b>Activation</b> This mode is accessible only when the drawer is in OFF mode. Press and hold the temperature decrease key (-) and the temperature increase key (+) for 5 seconds.	<b>Test Operation</b> The up/down buttons will be used to navigate through the tests and the ON/OFF button will be used to initiate the displayed test.	<b>Damper Test</b> Display shows "d1" for damper open, or "d0" for damper closed. Damper movement may take 30 seconds.	<b>Report NTC Temperature Test</b> Display shows "b1" for chamber sensor test. The UI display will show -°F until the main board responds with associated sensor temperature reading.
<b>Deactivation</b> Press and hold the temperature (+) key for 5 seconds, or no keys pressed in 5 minutes returns to the OFF mode of operation.	<b>Fan Test</b> Display shows "F1" for fan on or "F0" for fan off.	<b>To Test Damper</b> 1. Remove drawer. 2. Start damper test. 3. Observe damper moving open and closed. 4. Exit damper test.	<b>Display Test</b> "L0" for display test. The display test will cycle through all the display segments with a minimal on time for each segment.

**Fault Codes Listed on Diagram Sheet**

SYSTEM DIAGNOSTIC MODE		
<b>Activate:</b>	Press <b>FZ UP</b> and <b>FZ DOWN</b> for up to 10 sec. simultaneously. Press <b>FF UP</b> to advance through tests.	
<b>Deactivate:</b>	Press <b>FF UP</b> for up to 10 sec. Diagnostic Mode will automatically deactivate after 5 min. of inactivity. <b>Note: Silence alarm.</b>	
<ul style="list-style-type: none"> <li>• Tests marked with "*" may not be applicable to this unit and will not be displayed in System Diagnostic Mode.</li> <li>• Tests displayed in diagnostic mode but not described below are for internal purposes only; advance through.</li> <li>• View UI display for "on," "off," "CL," "OP," "SH," "LO," "HI" or numerical results of tests.</li> <li>• Listen for operating sounds; feel for heat or air flow as appropriate to determine results of tests.</li> </ul>		
Test	To activate test:	Passing result
-- First Screen	--	Blank UI display, no LEDs illuminated.
-- Second Screen	--	All LED lights on UI illuminated.
-- Third Screen	--	Blank UI display, no LEDs illuminated.
46 Humidity Sensor	Activates automatically	"OP" if open, "SH" if short. AC Heater System: Displays %RH. DC Heater System: "HI" - heater should be on. "Lo" - heater should be off. %RH is displayed when humidity is between "Lo" and "HI" values; heater could be on or off.
2 Freezer Defrost Heater	Press power on-off	Freezer defrost heater on when "on"; off when "off". Evaporator thermistor temperature is flashed. Watch for temp increase with the heater on. It may take a few minutes for the evaporator to heat up.
3 FF Lights powered by external board	Press power on-off	FF lights on when "on"; off when "off"
12 Condenser Fan	Press power on-off	Fan running when "on"; stopped when "off"
41 Perfect Temp Drawer (PTD)	Press power on-off	PTD UI illuminated when "on"; off when "off"
43 Mullion Anticondensation Heater	Press power on-off	Flip Mullion Heater on when "on"; off when "off"
38 VCC Compressor	Press power on-off	Compressor on when "on"; off when "off"
15 Freezer Evaporator Fan	Press power on-off	Press to toggle between "off", "Lo" and "HI". A current sensor reading is flashed (units are not mA). OFF reading should be around 2. "Lo" speed reading should settle down to around 9. "HI" speed reading should settle down above 40.
20 FZ Lights	Press power on-off	FZ lights on when "on"; off when "off"
22 Damper	Press power on-off	With inspection mirror, observe damper open when "OP"; closed when "CL"
23 FF Door	Open/close FF door	"CL" on UI when door closed; "OP" when open
24 FZ Door	Open/close FZ door	"CL" on UI when door closed; "OP" when open
29 FF Thermistor	Activates automatically	UI shows temperature sensed by FF thermistor; pass if within 10°F of temperature measured with gauge at FF thermistor location. "OP" if open; "SH" if short
30 FZ Thermistor	Activates automatically	UI shows temperature sensed by FZ thermistor; pass if within 10°F of temperature measured with gauge at FZ thermistor location. "OP" if open; "SH" if short
33 Ambient Thermistor @ Main Board	Activates automatically	UI shows temperature sensed at main board; pass if within +20°F/-10°F of temperature measured with gauge at main board location. "OP" if open; "SH" if short
34 Ambient Thermistor @ UI	Activates automatically	UI shows temperature sensed at UI; pass if within +20°F/-10°F of temperature measured with gauge at UI location. "OP" if open; "SH" if short
39 Freezer Evaporator Thermistor	Activates automatically	UI shows temperature sensed by freezer evaporator thermistor; pass if within 10°F of temperature measured with gauge at evaporator thermistor location. "OP" if open; "SH" if short
0- Firmware Parameters	Press power on-off	Displays digit sequence; record
1- Main Board Firmware	Press power on-off	Displays digit sequence; record
3- UI Firmware	Press power on-off	Displays digit sequence; record

**IMPORTANT SAFETY NOTE**

The information provided herein is designed to assist qualified repair personnel only. Untrained persons should not attempt to make repairs due to the possibility of electrical shock. Disconnect power cord before servicing this appliance.

**IMPORTANT**

If any green grounding wires are removed during servicing, they must be returned to their original position and properly secured.

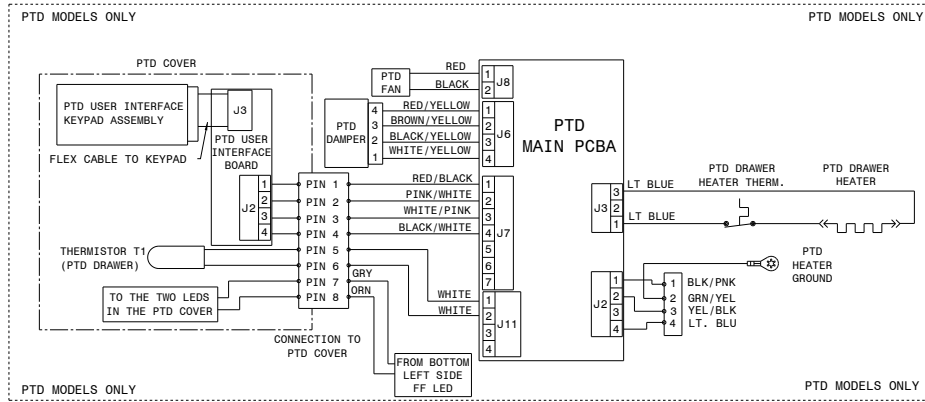

**PTD ERROR CODES:**

9X - SHORTED KEY/BUTTON, WHERE THE "X" IS:  
 1 FOR "ON/OFF"  
 2 FOR "+"  
 3 FOR "C/F"  
 4 FOR "-"  
 5 FOR "LOCK"  
 6 FOR "V" DOWN ARROW KEY  
 7 FOR "^^" UP ARROW KEY

2X - OPEN NTC, WHERE THE "X" IS:  
 1 FOR THE PTD DRAWER NTC

3X - SHORTED NTC, WHERE THE "X" IS:  
 1 FOR THE PTD DRAWER NTC

CE - LOSS OF COMMUNICATION BETWEEN UI AND MAIN PCB

HIF - UCL OVER TEMP TIME OUT EXCEEDED

LOF - LCL UNDER TEMP TIME OUT EXCEEDED

ABBR.	EXPLANATION
AT1	9 PIN CONNECTION AT AIR TOWER
LH1	5 PIN CONNECTION AT THE LEFT DOOR UPPER HINGE
MB1	9 PIN CONNECTION IN THE MAIN BOARD HOUSING BEHIND THE TOE GRILLE
MB2	4 PIN CONNECTION IN THE MAIN BOARD HOUSING BEHIND THE TOE GRILLE
MC1	9 PIN CONNECTION IN THE MACHINE COMPARTMENT TO THE LEFT OF THE COMPRESSOR
RH1	2 PIN CONNECTION AT THE RIGHT DOOR UPPER HINGE

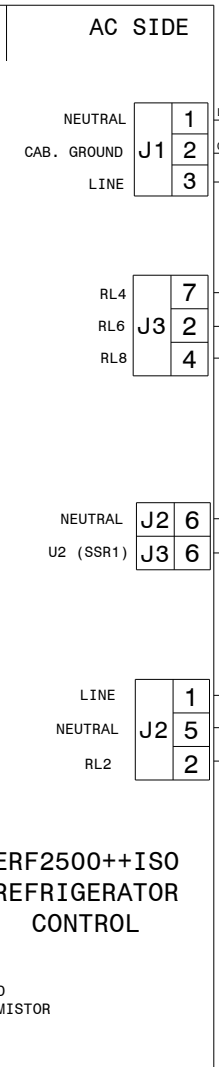
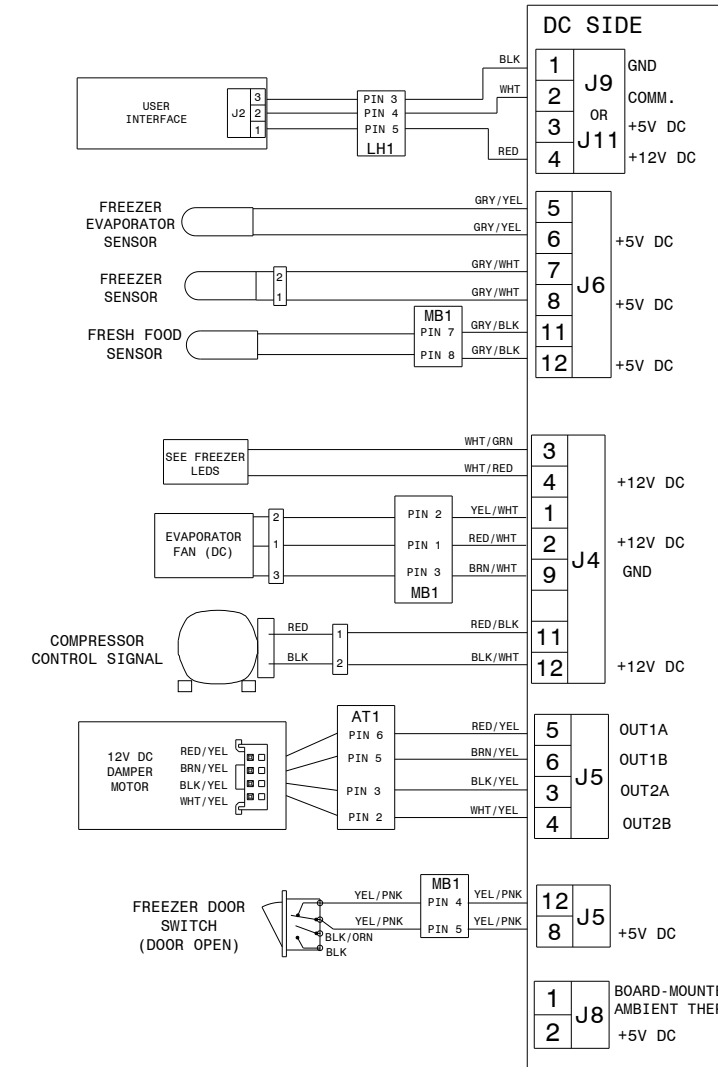
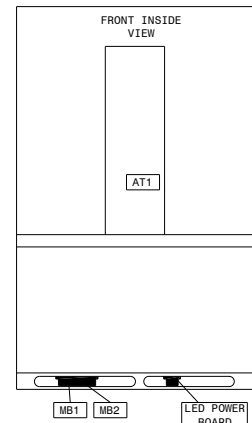
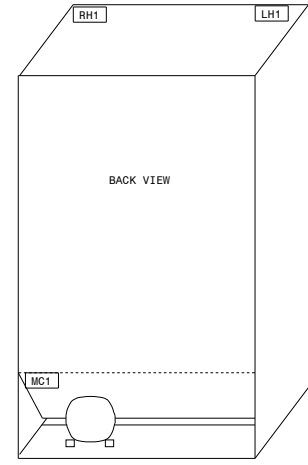

**ERF2500++ISO REFRIGERATOR CONTROL**

