

Dell 16

DC16256 (M)

Service Manual

Notes, cautions, and warnings

 **NOTE:** A NOTE indicates important information that helps you make better use of your product.

 **CAUTION:** A CAUTION indicates either potential damage to hardware or loss of data and tells you how to avoid the problem.

 **WARNING:** A WARNING indicates a potential for property damage, personal injury, or death.

Chapter 1: Working inside your computer	6
Safety instructions.....	6
Before working inside your computer.....	6
Safety precautions.....	7
Electrostatic discharge—ESD protection.....	7
ESD Field Service kit	8
Transporting sensitive components.....	9
After working inside your computer.....	9
Information on reparability for Québec - From Dell Canada Inc. - to Québec consumers.....	9
BitLocker.....	9
Recommended tools.....	9
Screw list.....	10
Major components of Dell 16 DC16256 (M).....	11
Customer Replaceable Units (CRUs) and Field Replaceable Units (FRUs) list.....	13
Chapter 2: Removing and installing Customer Replaceable Units (CRUs)	14
Base cover.....	14
Removing the base cover.....	14
Installing the base cover	17
Memory module.....	20
Removing the memory module	20
Installing the memory module	21
M.2 solid state drive.....	22
Removing the solid-state drive	22
Installing the solid-state drive	23
Wireless card.....	24
Removing the wireless card	24
Installing the wireless card	25
Speakers.....	26
Removing the speakers	26
Installing the speakers	27
Fan.....	29
Removing the fan	29
Installing the fan	30
Battery.....	31
Rechargeable Li-ion battery precautions.....	31
Removing the battery	32
Installing the battery	32
Battery cable.....	34
Installing the battery cable	34
Removing the battery cable	34
Chapter 3: Removing and installing Field Replaceable Units (FRUs)	37
Heat sink.....	37











Removing the heat sink	37
Installing the heat sink	38
Touchpad.....	39
Removing the touchpad assembly	39
Installing the touchpad assembly	40
Display assembly.....	42
Removing the display assembly	42
Installing the display assembly	43
I/O-board cable	45
Removing the I/O-board cable.....	45
Installing the I/O-board cable.....	46
I/O board.....	47
Removing the I/O board	47
Installing the I/O board	48
Power button.....	50
Removing the power button	50
Installing the power button	51
Power button with optional fingerprint reader.....	52
Removing the power button with optional fingerprint reader	52
Installing the power button with optional fingerprint reader	53
Power-adapter port.....	54
Removing the power-adapter port	54
Installing the power-adapter port	55
System board.....	56
Removing the system board	56
Installing the system board	60
Palm-rest and keyboard assembly.....	63
Removing the palm-rest and keyboard assembly	63
Installing the palm-rest and keyboard assembly	65
Chapter 4: Software.....	67
Operating system.....	67
Drivers and downloads.....	67
Chapter 5: BIOS Setup.....	68
Entering BIOS Setup program.....	68
Navigation keys.....	68
F12 One Time Boot menu.....	68
System setup options.....	69
Updating the BIOS.....	74
Updating the BIOS in Windows.....	74
Updating the BIOS using the USB drive in Windows.....	74
Updating the BIOS from the One-Time boot menu.....	75
System and setup password.....	75
Assigning a System Setup password.....	75
Deleting or changing an existing system password or setup password.....	76
Clearing system and setup passwords.....	76
Chapter 6: Troubleshooting.....	77

Handling swollen rechargeable Li-ion batteries.....	77
Dell SupportAssist Pre-boot System Performance Check diagnostics.....	77
Running the SupportAssist Pre-Boot System Performance Check.....	78
Built-in self-test (BIST).....	78
Motherboard Built-In Self-Test (M-BIST).....	78
Logic Built-in Self-test (L-BIST).....	79
LCD Built-in Self-Test (LCD-BIST).....	79
System-diagnostic lights.....	79
Recovering the operating system.....	80
Real-Time Clock (RTC Reset).....	81
Backup media and recovery options.....	81
Network power cycle.....	81
Drain flea power (perform hard reset).....	81
Chapter 7: Getting help and contacting Dell.....	83
Chapter 8: Revision history.....	84

Working inside your computer

Safety instructions

Use the following safety guidelines to protect your computer from potential damage and to ensure your personal safety. Unless otherwise noted, each procedure in this document assumes that you have read the safety information that shipped with your computer.

-  **WARNING:** Before working inside your computer, read the safety information that is shipped with your computer. For more safety best practices, see [Dell Regulatory Compliance Home Page](#).
-  **WARNING:** Disconnect your computer from all power sources before opening the computer cover or panels. After you finish working inside the computer, replace all covers, panels, and screws before connecting your computer to an electrical outlet.
-  **WARNING:** For laptops, discharge the battery completely before removing it. Disconnect the AC power adapter from the computer and operate the computer solely on battery power—the battery is fully discharged when the computer no longer turns on when the power button is pressed.
-  **CAUTION:** To avoid damaging the computer, ensure that the work surface is flat, dry, and clean.
-  **CAUTION:** You should only perform troubleshooting and repairs as authorized or directed by the Dell technical support team. Damage due to servicing that is not authorized by Dell is not covered by your warranty.
-  **CAUTION:** Before touching anything inside your computer, ground yourself by touching an unpainted metal surface, such as the metal at the back of the computer. While you work, periodically touch an unpainted metal surface to dissipate static electricity which could harm internal components.
-  **CAUTION:** To avoid damaging the components and cards, handle them by their edges, and avoid touching the pins and the contacts.
-  **CAUTION:** When you disconnect a cable, pull it by its connector or its pull tab, not the cable itself. Some cables have connectors with locking tabs or thumbscrews that you must disengage before disconnecting the cable. When disconnecting cables, keep them evenly aligned to avoid bending the connector pins. When connecting cables, ensure that the connector on the cable is correctly oriented and aligned with the port.
-  **CAUTION:** Press and eject any installed card from the media-card reader.
-  **CAUTION:** Exercise caution when handling rechargeable Li-ion batteries in laptops. Swollen batteries should not be used and should be replaced and disposed properly.

Before working inside your computer

About this task

 **NOTE:** The images in this document may differ from your computer depending on the configuration you ordered.

Steps

1. Save and close all open files and exit all open applications.
2. Shut down your computer. For Windows operating system, click **Start** >  **Power** > **Shut down**.

 **NOTE:** If you are using a different operating system, see the documentation of your operating system for shut-down instructions.

3. Turn off all the attached peripherals.
4. Disconnect your computer from the electrical outlet.
5. Disconnect all attached network devices and peripherals, such as keyboard, mouse, and monitor from your computer.

 **CAUTION:** To disconnect a network cable, unplug the cable from your computer.

6. Remove any media card and optical disc from your computer, if applicable.

Safety precautions

This section details the primary steps to be followed before disassembling any device or component.

Observe the following safety precautions before any installation or break-fix procedures involving disassembly or reassembly:

- Turn off the computer and all attached peripherals.
- Disconnect the computer from AC power.
- Disconnect all network cables and peripherals from the computer.
- Use an ESD field service kit when working inside your computer to avoid electrostatic discharge (ESD) damage.
- Place the removed component on an anti-static mat after removing it from the computer.
- Press and hold the power button for 15 seconds to discharge the residual power in the system board.

Bonding

Bonding is a method for connecting two or more grounding conductors to the same electrical potential. This is done by using a field service electrostatic discharge (ESD) kit. When connecting a bonding wire, ensure that it is connected to bare metal and never to a painted or nonmetal surface. Ensure that the wrist strap is secure and in full contact with your skin. Remove all jewelry, watches, bracelets, or rings before grounding yourself and the equipment.

Electrostatic discharge—ESD protection

ESD is a major concern when you handle electronic components, especially sensitive components such as expansion cards, processors, memory modules, and system boards. A slight charge can damage circuits in ways that may not be obvious, such as intermittent problems or a shortened product life span. As the industry pushes for lower power requirements and increased density, ESD protection is an increasing concern.

Two recognized types of ESD damage are catastrophic and intermittent failures.

- **Catastrophic** – Catastrophic failures represent approximately 20 percent of ESD-related failures. The damage causes an immediate and complete loss of device functionality. An example of catastrophic failure is a memory module that has received a static shock and immediately generates a "No POST/No Video" symptom with a beep code that is emitted for missing or nonfunctional memory.
- **Intermittent** – Intermittent failures represent approximately 80 percent of ESD-related failures. The high rate of intermittent failures means that most of the time when damage occurs, it is not immediately recognizable. The memory module receives a static shock, but the tracing is merely weakened and does not immediately produce outward symptoms that are related to the damage. The weakened trace may take weeks or months to melt, and in the meantime may cause degradation of memory integrity, intermittent memory errors, and so on.

Intermittent failures that are also called latent or "walking wounded" are difficult to detect and troubleshoot.

Perform the following steps to prevent ESD damage:

- Use a wired ESD wrist strap that is properly grounded. Wireless anti-static straps do not provide adequate protection. Touching the chassis before handling parts does not ensure adequate ESD protection on parts with increased sensitivity to ESD damage.
- Handle all static-sensitive components in a static-safe area. If possible, use anti-static floor pads and workbench pads.
- When unpacking a static-sensitive component from its shipping carton, do not remove the component from the anti-static packing material until you are ready to install the component. Before unwrapping the anti-static packaging, use the anti-static wrist strap to discharge the static electricity from your body.

NOTE: You can protect against ESD and discharge static electricity from your body by touching a metal-grounded object before you interact with anything electronic, for example, an unpainted metal surface on your computer's I/O panel. When connecting a peripheral (including handheld digital assistants) to your computer, you should always ground both yourself and the peripheral before connecting it to the computer. In addition, as you work inside the computer, periodically touch a metal-grounded object to remove any static charge that your body may have accumulated.

For more information about the wrist strap and ESD wrist strap tester, see [Components of an ESD Field Service Kit](#).

- Before transporting a static-sensitive component, place it in an anti-static container or packaging.

ESD Field Service kit

The unmonitored field service kit is the most commonly used service kit. Each Field Service kit includes three main components: anti-static mat, wrist strap, and bonding wire.

CAUTION: It is critical to keep ESD-sensitive devices away from internal parts that are insulated and often highly charged, such as plastic heat sink casings.

Working environment

Before the ESD Field Service kit is deployed, conduct an evaluation of the site to ensure proper setup and readiness. For example, deploying the kit for a server environment is different than for a desktop or laptop environment. Servers are typically installed in a rack within a data center; desktops or laptops are typically placed on office desks or cubicles. Always look for a large open flat work area that is free of clutter and large enough to deploy the ESD kit with additional space to accommodate the type of computer that is being repaired. The workspace should also be free of insulators that can cause an ESD event. On the work area, insulators such as styrofoam and other plastics should always be moved at least 12 inches or 30 centimeters away from sensitive parts before physically handling any hardware components.

ESD packaging

All ESD-sensitive devices must be shipped and received in static-safe packaging. Metal, static-shielded bags are preferred. However, you should always return the damaged component using the same ESD bag and packaging that the new part arrived in. The ESD bag should be folded over and taped shut and all the same foam packing material should be used in the original box that the new part arrived in. ESD-sensitive devices should be removed from packaging only at an ESD-protected work surface, and parts should never be placed on top of the ESD bag because only the inside of the bag is shielded. Always place parts in your hand, on the anti-static mat, in the computer, or inside an ESD bag.

Components of an ESD Field Service kit

The components of an ESD Field Service kit are:

- **Anti-Static Mat** – The anti-static mat is dissipative and parts can be placed on it during service procedures. When using an anti-static mat, your wrist strap should be snug and the bonding wire should be connected to the anti-static mat and to any bare metal on the computer being worked on. Once deployed properly, service parts can be removed from the ESD bag and placed directly on the anti-static mat. ESD-sensitive items are safe in your hand, on the anti-static mat, in the computer, or inside an ESD bag.
- **Wrist Strap and Bonding Wire** – If an anti-static mat is not being used, the wrist strap and bonding wire should be connected directly between your wrist and an exposed metal part of the hardware. If you are using an anti-static mat, connect the wrist strap and bonding wire to the anti-static mat to ensure protection for any hardware placed on the mat. The physical connection of the wrist strap and bonding wire between your skin, the anti-static mat, and the hardware is known as bonding. Use only Field Service kits with a wrist strap, anti-static mat, and bonding wire. Never use wireless wrist straps. Always be cautious that the internal wires of a wrist strap are prone to damage from normal wear and tear, and must be checked regularly with a wrist strap tester in order to avoid accidental ESD hardware damage. It is recommended to test the wrist strap and bonding wire at least once per week.
- **ESD Wrist Strap Tester** – The wires inside an ESD strap are prone to damage over time. When using an unmonitored ESD kit, it is recommended to test the wrist strap regularly—ideally before each service session, and at a minimum, once per week. The most reliable method for testing is with a wrist strap tester. To perform the test, connect the bonding wire of the wrist strap to the tester while wearing the strap. Press the test button to initiate the check. A green LED indicates a successful test, while a red LED and audible alarm signal a failure.

 **NOTE:** It is recommended to always use the traditional wired ESD grounding wrist strap and protective anti-static mat when servicing Dell products. In addition, it is critical to keep sensitive parts separate from all insulator parts while servicing the computer.

Transporting sensitive components

When transporting ESD sensitive components such as replacement parts or parts to be returned to Dell, it is critical to place these parts in anti-static bags for safe transport.

After working inside your computer

About this task

 **CAUTION:** Leaving stray or loose screws inside your computer may severely damage your computer.

Steps

1. Replace all screws and ensure that no stray screws remain inside your computer.
2. Connect any external devices, peripherals, or cables you removed before working on your computer.
3. Replace any media cards, discs, or any other components that you removed before working on your computer.
4. Connect your computer and all attached devices to their electrical outlets.
5. Turn on your computer.

Information on repairability for Québec - From Dell Canada Inc. - to Quebec consumers

Dell does not guarantee the availability of replacement parts, repair services, or information necessary for maintenance or repair.

BitLocker

When updating the BIOS on a computer with BitLocker enabled, consider the following precautions.

 **CAUTION:** If BitLocker is not suspended before updating the BIOS, the BitLocker key will not be recognized the next time that you reboot the computer. You are prompted to enter the recovery key to progress, and the computer displays a prompt for the recovery key on each reboot. If the recovery key is not known, this can result in data loss or an operating system reinstall. For more information, see Knowledge Article: [updating the BIOS on Dell computers with BitLocker enabled](#).

The installation of the following components triggers BitLocker:

- Hard disk drive or solid state drive
- System board

Recommended tools

The procedures in this document may require the following tools:

- Phillips screwdriver #0
- Plastic scribe



Screw list

- NOTE:** When removing screws from a component, it is recommended to note the screw type and the quantity of screws, and then place them in a screw storage box. This is to ensure that the correct number of screws and correct screw type is restored when the component is replaced.
- NOTE:** Some computers have magnetic surfaces. Ensure that the screws are not left attached to such surfaces when replacing a component.
- NOTE:** Screw color may vary depending on the configuration ordered.

Table 1. Screw list

Component	Screw type	Quantity	Screw Torque Strength	Screw image
Base cover	Captive screw	2	1.6 kgf.cm to 1.9 kgf.cm	
	M2x5.5	6	1.6 kgf.cm to 1.9 kgf.cm	
Solid-state drive mounting bracket	M2x3.5	3	1.6 kgf.cm to 1.9 kgf.cm	
Solid-state drive	M1.6x1.8	1	1.0 kgf.cm to 1.2 kgf.cm	
Wireless card	M2x3.5	1	1.6 kgf.cm to 1.9 kgf.cm	
Fan	M2x5.5	2	1.6 kgf.cm to 1.9 kgf.cm	
Battery	M2x3.5	5	1.6 kgf.cm to 1.9 kgf.cm	
Heat sink	Captive screws	4	1.6 kgf.cm to 1.9 kgf.cm	
Touchpad assembly	M2x2.3	7	1.0 kgf.cm to 1.2 kgf.cm	
Hinges	M2.5x5.5	5 NOTE: Right hinge - 2 screws Left hinge - 3 screws	2.7 kgf.cm to 3.3 kgf.cm	
I/O board	M2x3.5	3	1.6 kgf.cm to 1.9 kgf.cm	
Power button	M2x2.3	1	1.0 kgf.cm to 1.2 kgf.cm	
Power button with fingerprint reader (optional)	M2x2.3	1	1.0 kgf.cm to 1.2 kgf.cm	

Table 1. Screw list (continued)

Component	Screw type	Quantity	Screw Torque Strength	Screw image
System board	M2x3.5	4	1.6 kgf.cm to 1.9 kgf.cm	
	M1.6x1.8	1	1.0 kgf.cm to 1.2 kgf.cm	
USB Type-C bracket NOTE: A USB Type-C bracket is secured to the system board with a single screw (M2x3.5). The bracket is bundled with the system board as a service part and MUST NOT be removed from the system board.	M2x3.5	1	1.6 kgf.cm to 1.9 kgf.cm	

Major components of Dell 16 DC16256 (M)

The following image shows the major components of Dell 16 DC16256 (M).

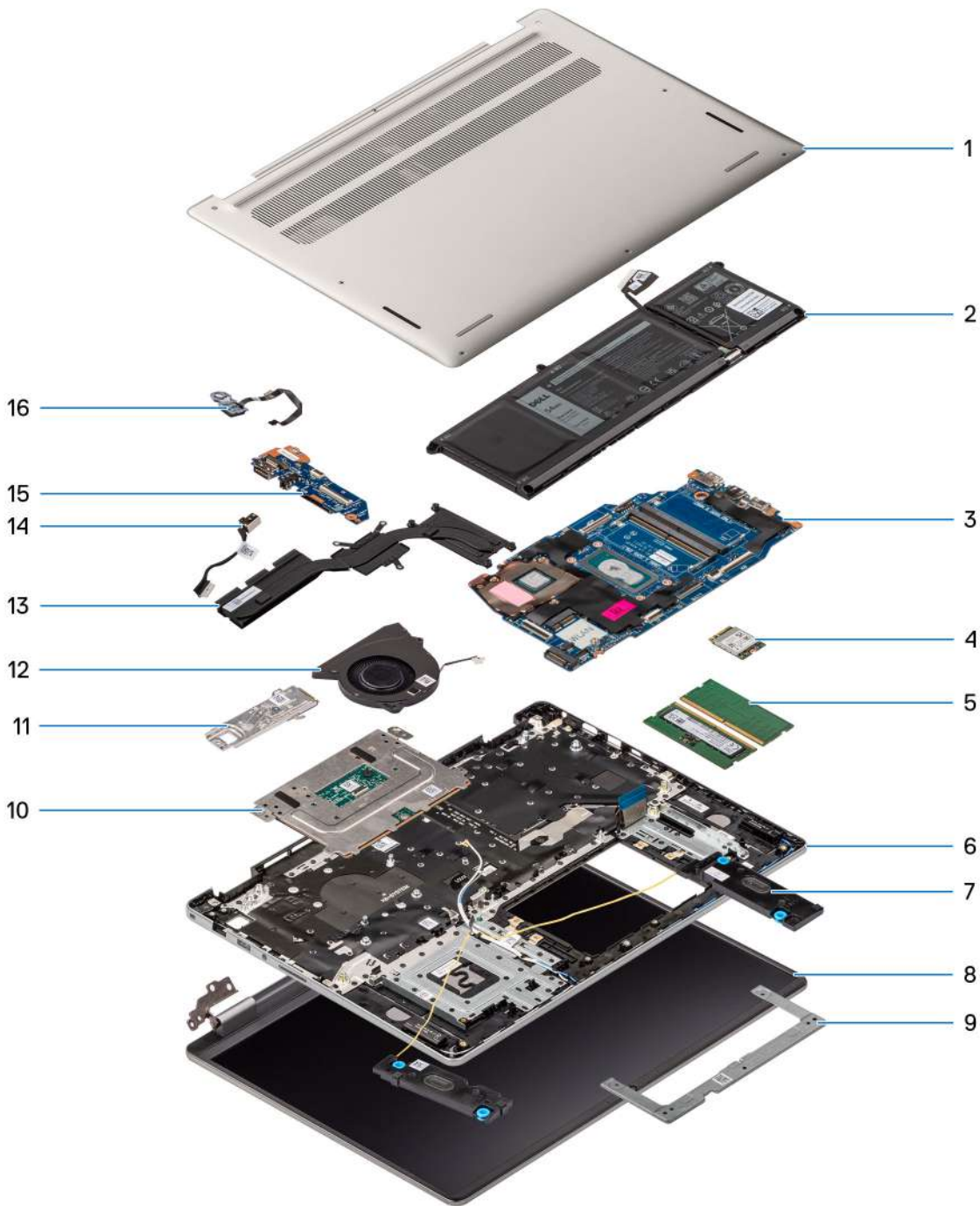

- | | |
|---|---|
| 1. Base cover | 2. Battery |
| 3. System board | 4. Wireless card |
| 5. Memory modules | 6. Palm-rest and keyboard assembly |
| 7. Speakers | 8. Display assembly |
| 9. Touchpad bracket | 10. Touchpad assembly |
| 11. M.2 2230 solid-state drive with thermal plate | 12. Fan |
| 13. Heat sink | 14. Power-adaptor port |
| 15. I/O board | 16. Power button with optional fingerprint reader |

NOTE: Dell provides a list of components and their part numbers for the original computer configuration purchased. These parts are available depending on the warranty coverage selected at the time of purchase. Components from upsell

or upgraded variants may not be covered under the standard system warranty. For more details or to explore purchase options, contact your Dell sales representative.

Customer Replaceable Units (CRUs) and Field Replaceable Units (FRUs) list

The replaceable components in Dell 16 DC16256 (M) are either Customer Replaceable Units (CRUs) or Field Replaceable Units (FRUs).

CAUTION: To avoid any potential damage to the component or loss of data, ensure that an authorized service technician replaces the Field Replaceable Units (FRUs). Customers can replace only the Customer Replaceable Units (CRUs) following the safety precautions and replacement procedures.

Table 2. CRU and FRU list

Customer Replaceable Unit (CRU)	Field Replaceable Unit (FRU)
Base cover	Heat sink
Memory modules	Touchpad assembly
M.2 2230 solid-state drive	I/O board cable
Wireless card	I/O board
Speakers	Power button
Fan	Power button with fingerprint reader (optional)
Battery	Power-adapter port
Battery cable	Display assembly
	System board
	Palm-rest and keyboard assembly

Removing and installing Customer Replaceable Units (CRUs)

The replaceable components in this chapter are Customer Replaceable Units (CRUs).

 **CAUTION:** Customers can replace only the Customer Replaceable Units (CRUs) following the safety precautions and replacement procedures.

 **NOTE:** The images in this document may differ from your computer depending on the configuration you ordered.

Base cover

Removing the base cover

Prerequisites

1. Follow the procedure in [Before working inside your computer](#).

About this task

The following images indicate the location of the base cover and provide a visual representation of the removal procedure.



2x



6x
M2x5.5

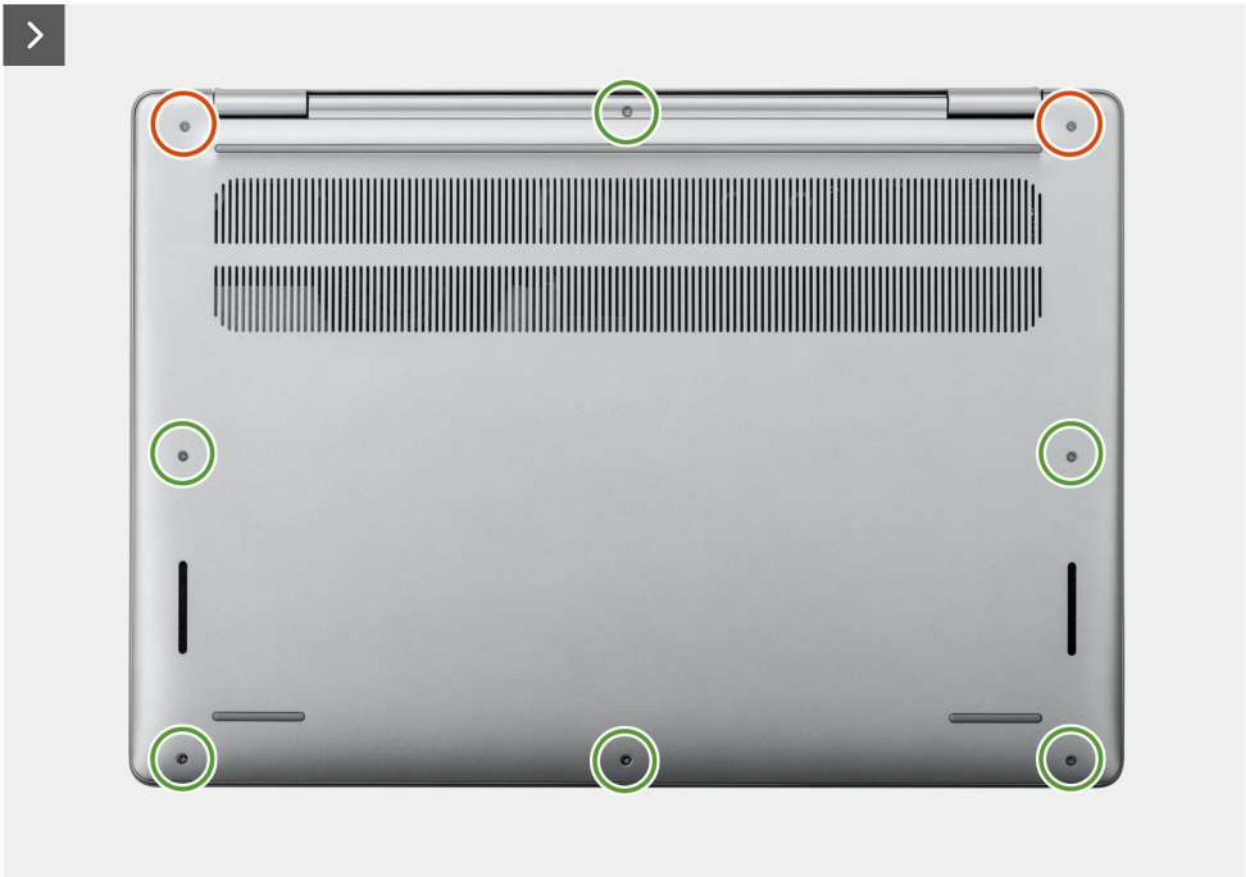

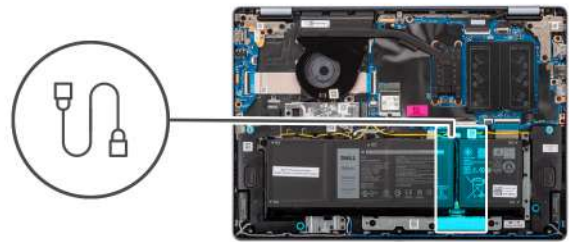
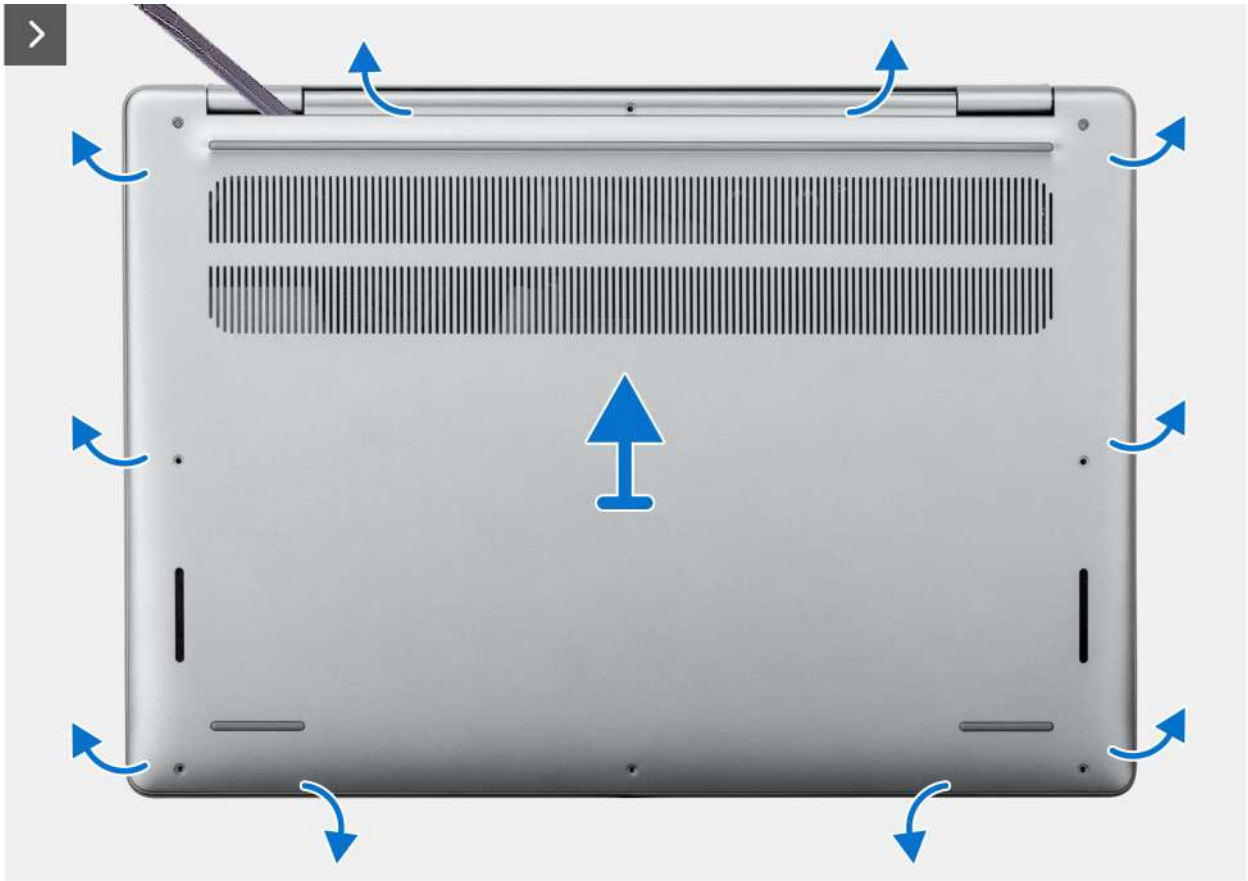



Figure 1. Removing the base cover

Steps

1. Remove the six screws (M2x5.5) and loosen the two captive screws that secure the base cover to the palm-rest and keyboard assembly.
2. Using a plastic scribe, pry open the base cover starting from the recesses, which are located in the U-shaped indents at the top edge of the base cover, near the hinges.
3. Pry open the top side of the base cover and continue working on the left and right sides to open the base cover.
4. Lift and remove the base cover off the palm-rest and keyboard assembly.
5. Disconnect the battery cable from its connector (BATT) on the system board.
6. Press and hold the power button for five seconds to ground the computer and drain the flea power.

Installing the base cover

Prerequisites

If you are replacing a component, remove the existing component before performing the installation procedure.

About this task

The following images indicate the location of the base cover and provide a visual representation of the installation procedure.

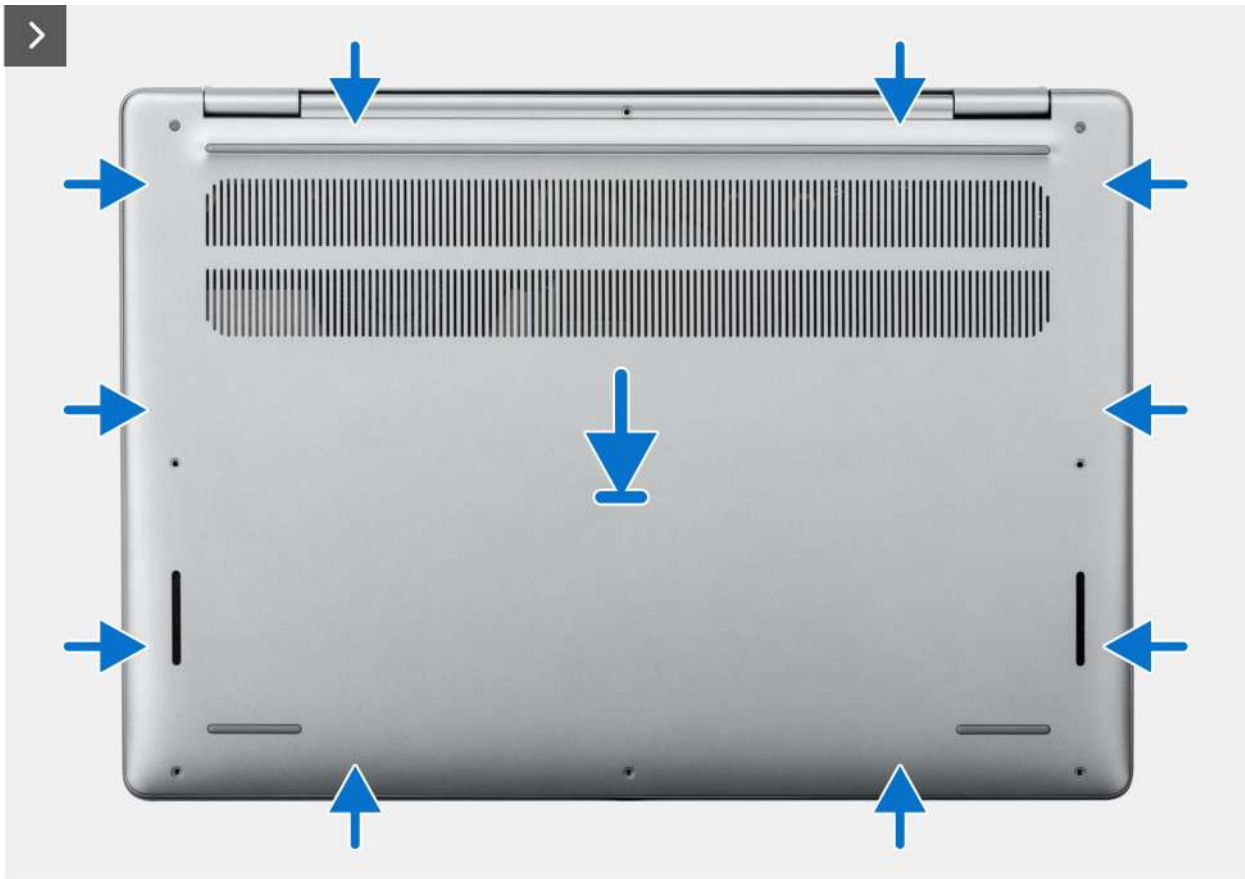
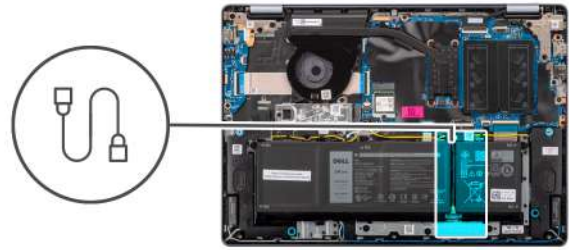



Figure 2. Installing the base cover

Steps

1. Connect the battery cable to its connector (BATT) on the system board.
2. Place the base cover on top of the palm-rest and keyboard assembly.
3. Align the screw holes on the base cover with the screw holes on the palm-rest and keyboard assembly, and snap the base cover latches into place.
4. Tighten the two captive screws and replace the six screws (M2x5.5) that secure the base cover to the palm-rest and keyboard assembly.

Next steps

1. Follow the procedure in [After working inside your computer.](#)

Memory module

Removing the memory module

Prerequisites

1. Follow the procedure in [Before working inside your computer](#).
2. Remove the [base cover](#).

About this task

The following images indicate the location of the memory module and provide a visual representation of the removal procedure.

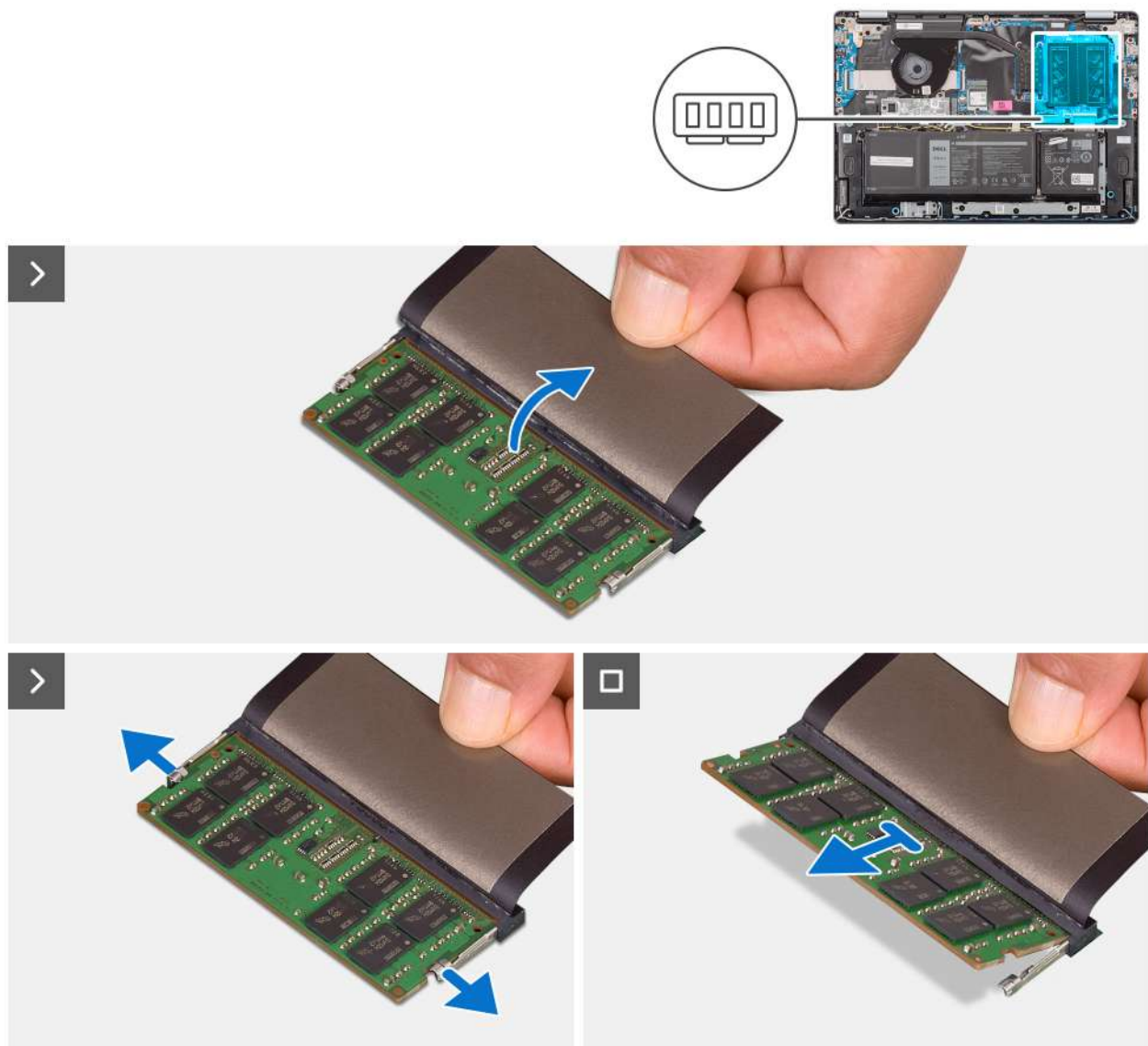

Figure 3. Removing the memory module

Steps

1. Lift the Mylar to access the memory module.
2. Use your fingertips to spread apart the securing clips on each end of the memory module slot until the memory module pops up.

CAUTION: To prevent damage to the memory module, hold the memory module by the edges. Do not touch the components or metallic contacts on the memory module as electrostatic discharge (ESD) can inflict severe damage on the components. To read more about ESD protection, see [ESD protection](#).

- Slide the memory module at an angle and remove it from the memory-module slot (DIMM A DDR5 ONLY or DIMM B DDR5 ONLY) on the system board.

Installing the memory module

Prerequisites

If you are replacing a component, remove the existing component before performing the installation procedure.

About this task

The following images indicate the location of the memory module and provide a visual representation of the installation procedure.

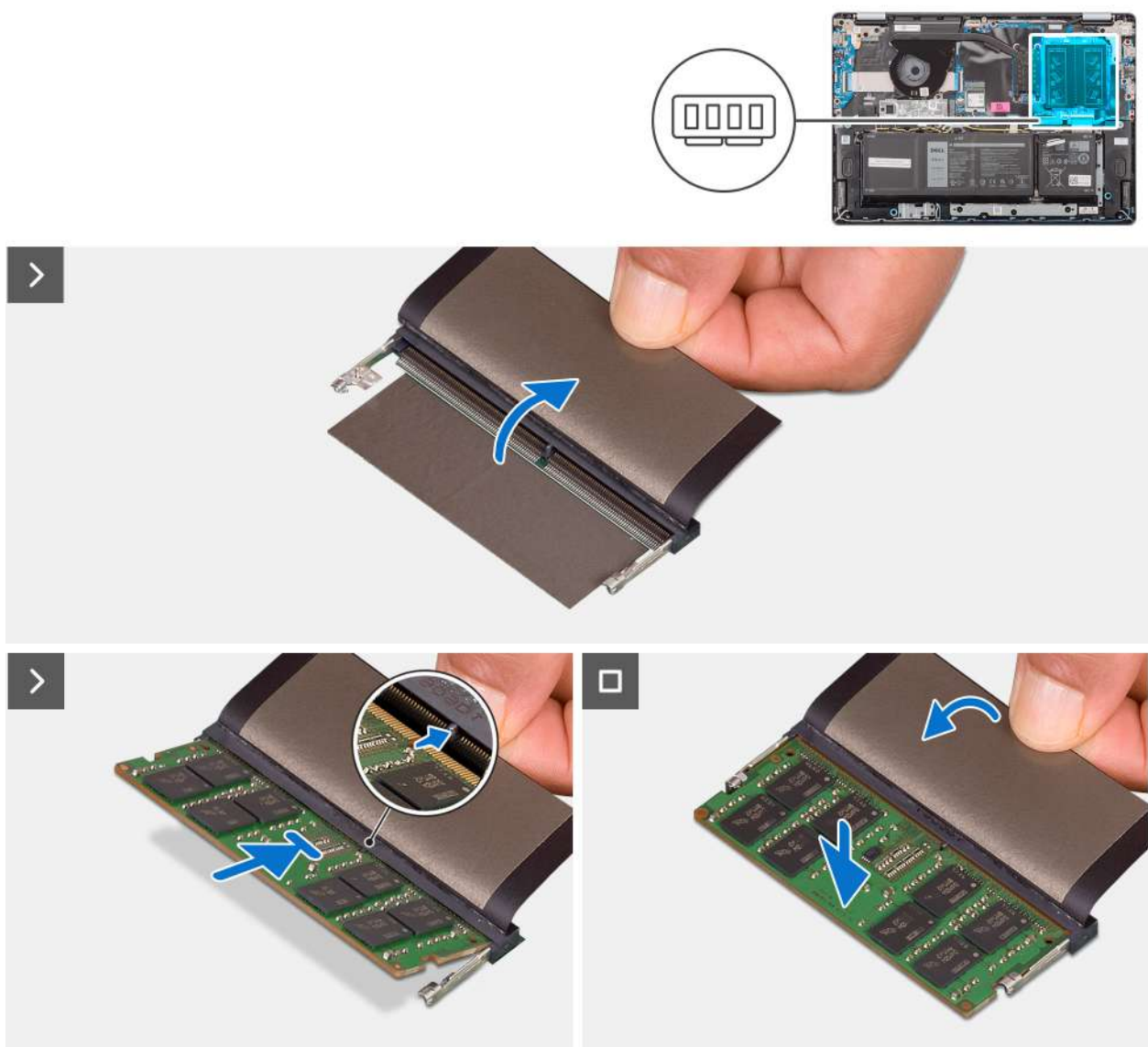

Figure 4. Installing the memory module

Steps

- Lift the Mylar to access the memory-module slot.

- Align the notch on the memory module with the tab on the memory-module slot (DIMM A DDR5 ONLY or DIMM B DDR5 ONLY) on the system board.

CAUTION: To prevent damage to the memory module, hold the memory module by the edges. Do not touch the components or metallic contacts on the memory module as electrostatic discharge (ESD) can inflict severe damage on the components. To read more about ESD protection, see [ESD protection](#).

- Slide the memory module firmly into the memory-module slot at an angle.
- Press down on the memory module to snap it into place on the system board. Ensure that the memory-module retention clips have locked the memory module into place.

NOTE: If you do not hear the click, remove the memory module and reinstall it.

Next steps

- Install the [base cover](#).
- Follow the procedure in [After working inside your computer](#).

M.2 solid state drive

Removing the solid-state drive

Prerequisites

- Follow the procedure in [Before working inside your computer](#).
- Remove the [base cover](#).

About this task

The following images indicate the location of the solid-state drive and provide a visual representation of the removal procedure.

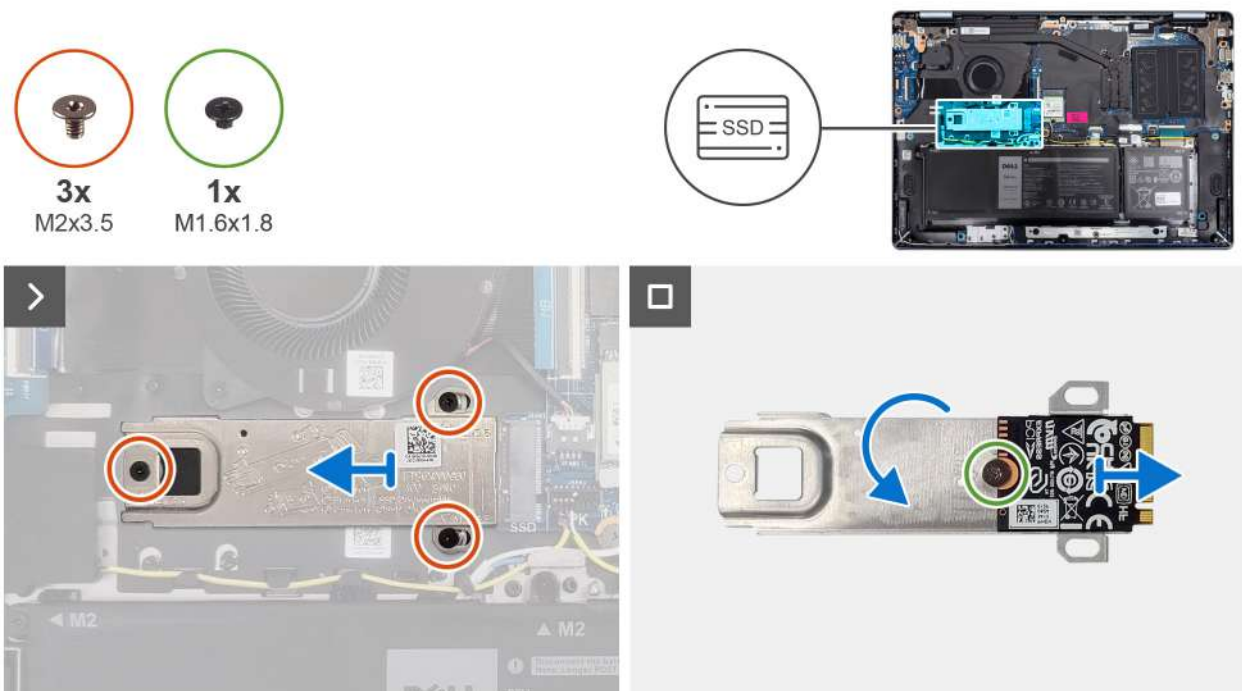

Figure 5. Removing the solid-state drive

Steps

- Remove the three screws (M2x3.5) that secure the solid-state drive assembly to the system board.

- Slide and lift the solid-state drive assembly from the M.2 card slot (SSD) on the system board.
- Flip over the solid-state drive assembly and remove the screw (M1.6x1.8) that secures the solid-state drive to the thermal plate.
- Lift the solid-state drive off the thermal plate.

Installing the solid-state drive

Prerequisites

If you are replacing a component, remove the existing component before performing the installation procedure.

About this task

The following images indicate the location of the solid-state drive and provide a visual representation of the installation procedure.

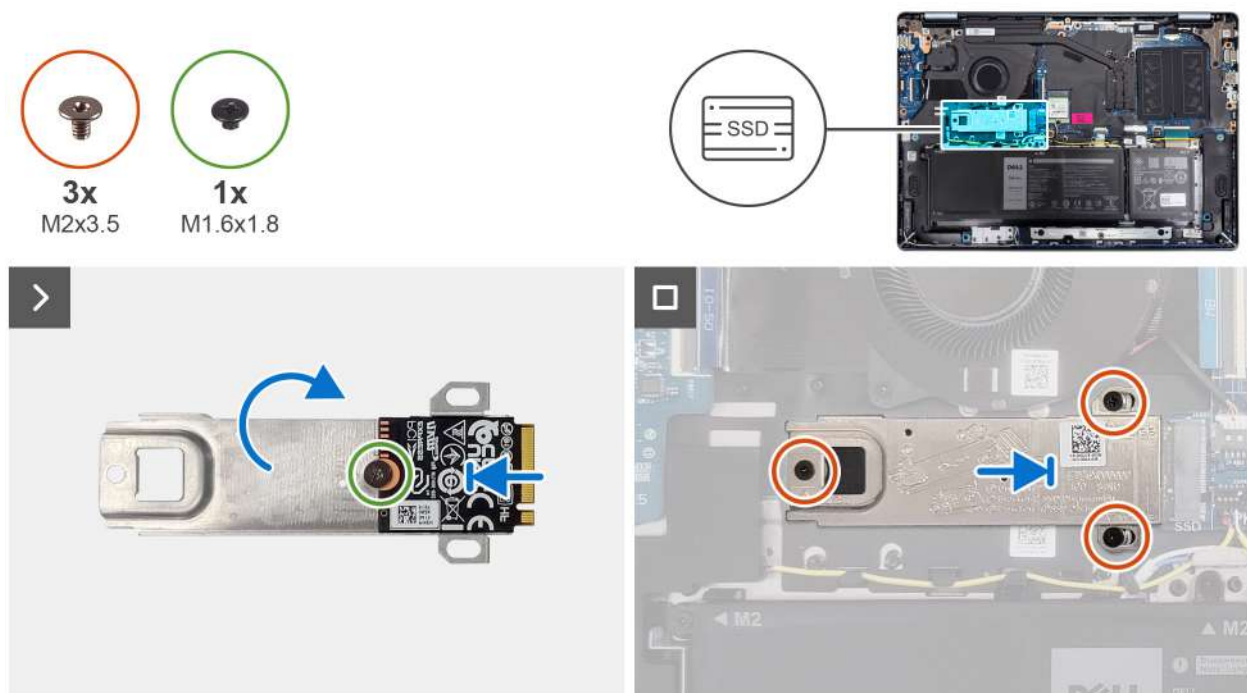

Figure 6. Installing the solid-state drive

Steps

- Align and place the solid-state drive on the thermal plate.
- Replace the screw (M1.6x1.8) that secures the solid-state drive to the thermal plate.
- Flip over the M.2 2230 solid-state drive assembly.
- Align the notch on the solid-state drive with the tab on the M.2 card slot (SSD) on the system board.
- Slide the solid-state drive in the M.2 card slot (SSD) on the system board.
- Align the screw holes on the thermal plate with the screw holes on the system board.
- Replace the three screws (M2x3.5) that secure the solid-state drive assembly to the system board.

Next steps

- Install the [base cover](#).
- Follow the procedure in [After working inside your computer](#).

Wireless card

Removing the wireless card

Prerequisites

1. Follow the procedure in [Before working inside your computer](#).
2. Remove the [base cover](#).

About this task

The following images indicate the location of the wireless card and provide a visual representation of the removal procedure.

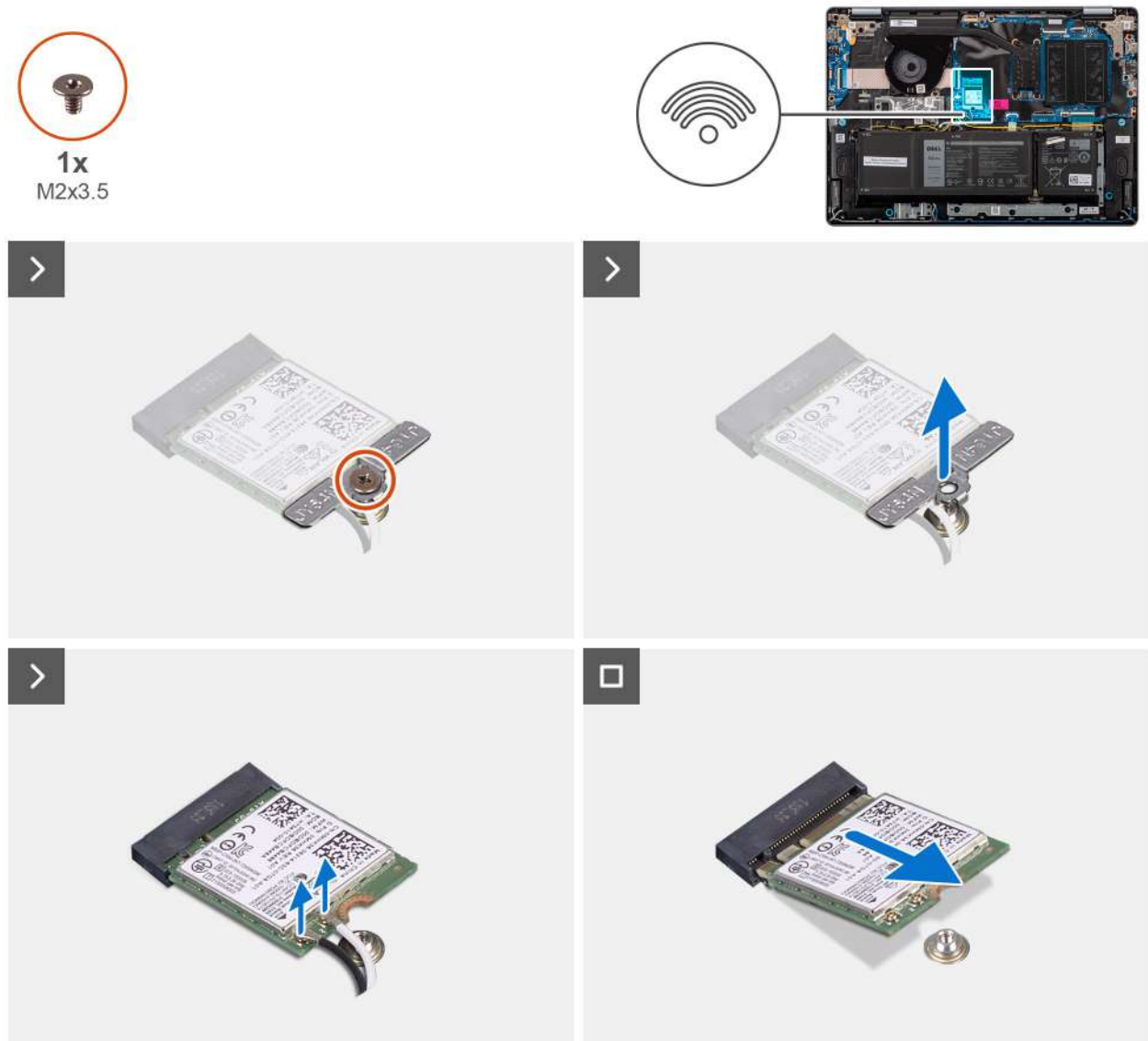

Figure 7. Removing the wireless card

Steps

1. Remove the screw (M2x3.5) that secures the wireless-card bracket to the system board.
2. Lift the wireless-card bracket off the wireless card.
3. Disconnect the wireless-antenna cables from the connectors on the wireless card.
4. Slide and remove the wireless card from the wireless-card slot (WLAN) on the system board.

Installing the wireless card

Prerequisites

If you are replacing a component, remove the existing component before performing the installation procedure.

About this task

The following images indicate the location of the wireless card and provide a visual representation of the installation procedure.

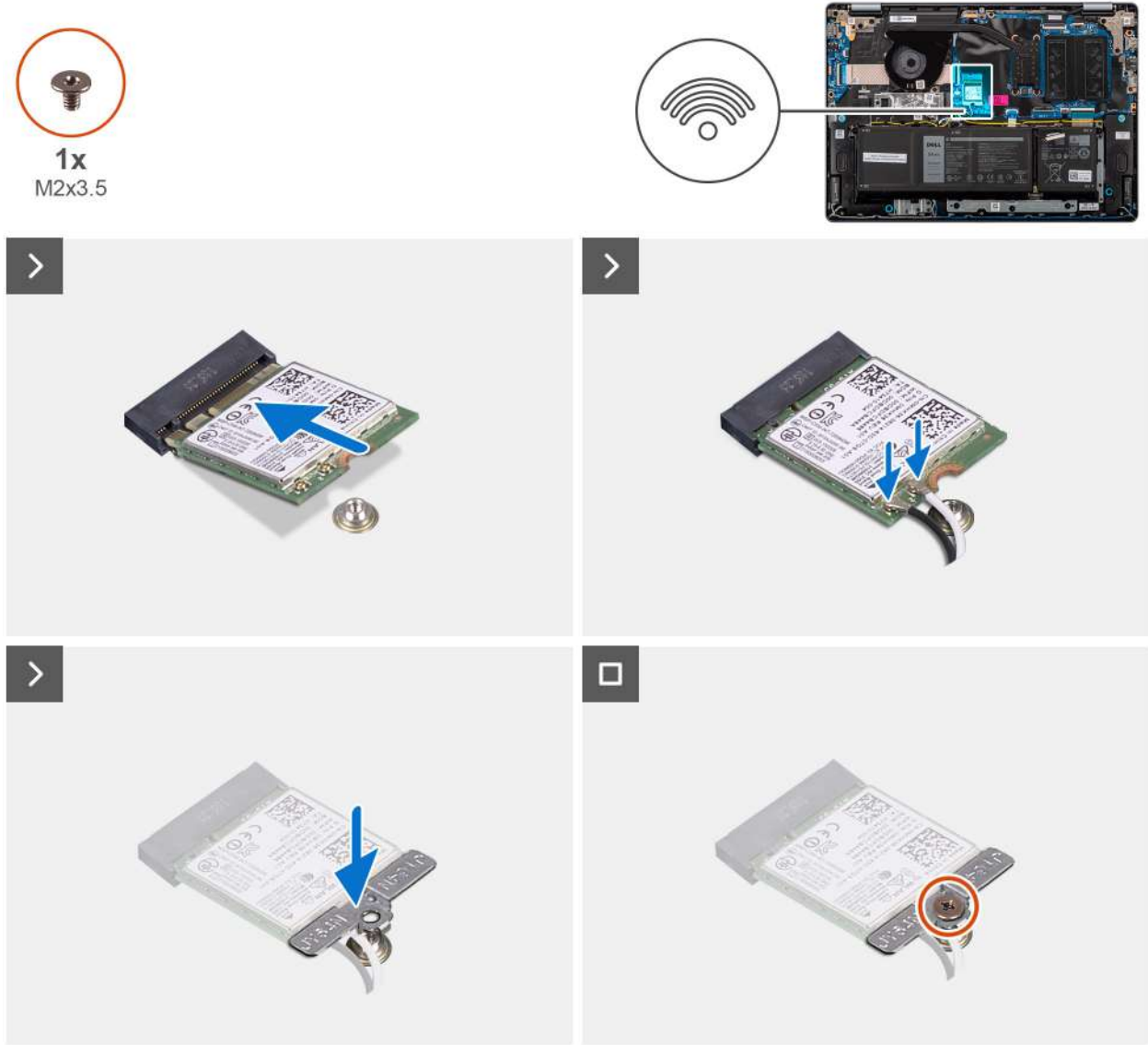

Figure 8. Installing the wireless card

Steps

1. Connect the wireless-antenna cables to the wireless card.

The following table provides the antenna-cable color scheme for the wireless card that is supported by your computer.

Table 3. Antenna-cable color scheme

Connector on the wireless card	Antenna-cable color	Silkscreen marking	
Main	White	MAIN	△ (white triangle)

Table 3. Antenna-cable color scheme (continued)

Connector on the wireless card	Antenna-cable color	Silkscreen marking	
Auxiliary	Black	AUX	▲ (black triangle)

2. At an angle, slide the wireless card into the wireless-card slot (WLAN) on the system board.
3. Place the wireless-card bracket on the wireless card.
4. Align the screw hole on the wireless-card bracket with the screw hole on the system board.
5. Replace the screw (M2x3.5) that secure the wireless-card bracket and the wireless card to the system board.

Next steps

1. Install the [base cover](#).
2. Follow the procedure in [After working inside your computer](#).

Speakers

Removing the speakers

Prerequisites

1. Follow the procedure in [Before working inside your computer](#).
2. Remove the [base cover](#).

About this task

The following image indicates the location of the speakers and provides a visual representation of the removal procedure.

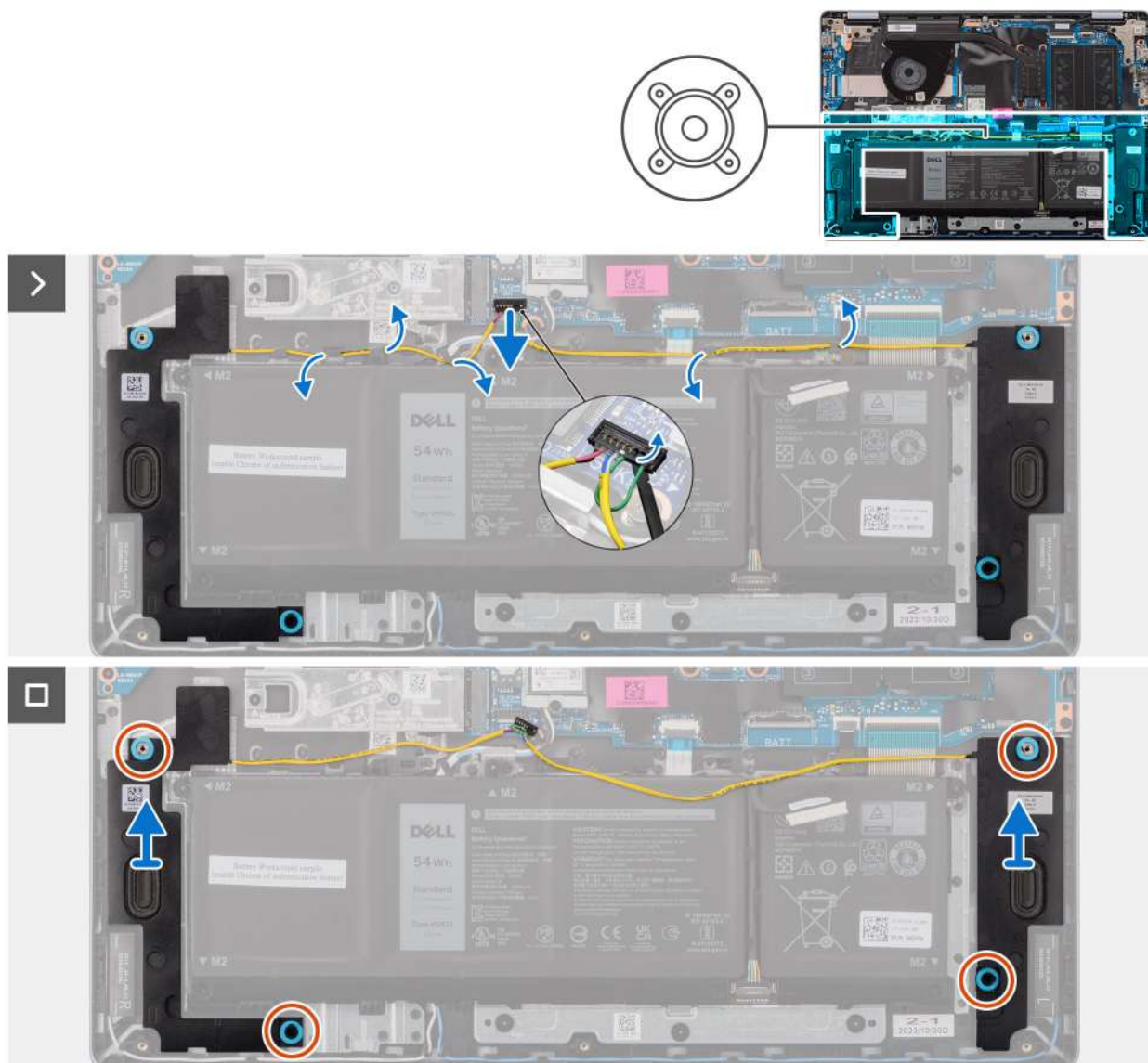

Figure 9. Removing the speakers

Steps

1. To disconnect the speaker cable, use a plastic scribe to pry up the bottom edge of the cable connector head and lift it from the slot (SPK) on the system board.

CAUTION: DO NOT pull the speaker cables downward while disconnecting the speaker cable from the system board.

2. Unroute and remove the speaker cable from the routing guides on palm-rest and keyboard assembly.
3. Lift the speakers, along with the cable, off the palm-rest and keyboard assembly.

Installing the speakers

Prerequisites

If you are replacing a component, remove the existing component before performing the installation procedure.

About this task

NOTE: If the rubber grommets are pushed out when removing the speakers, push them back in before replacing the speakers.

The following image indicates the location of the speakers and provides a visual representation of the installation procedure.

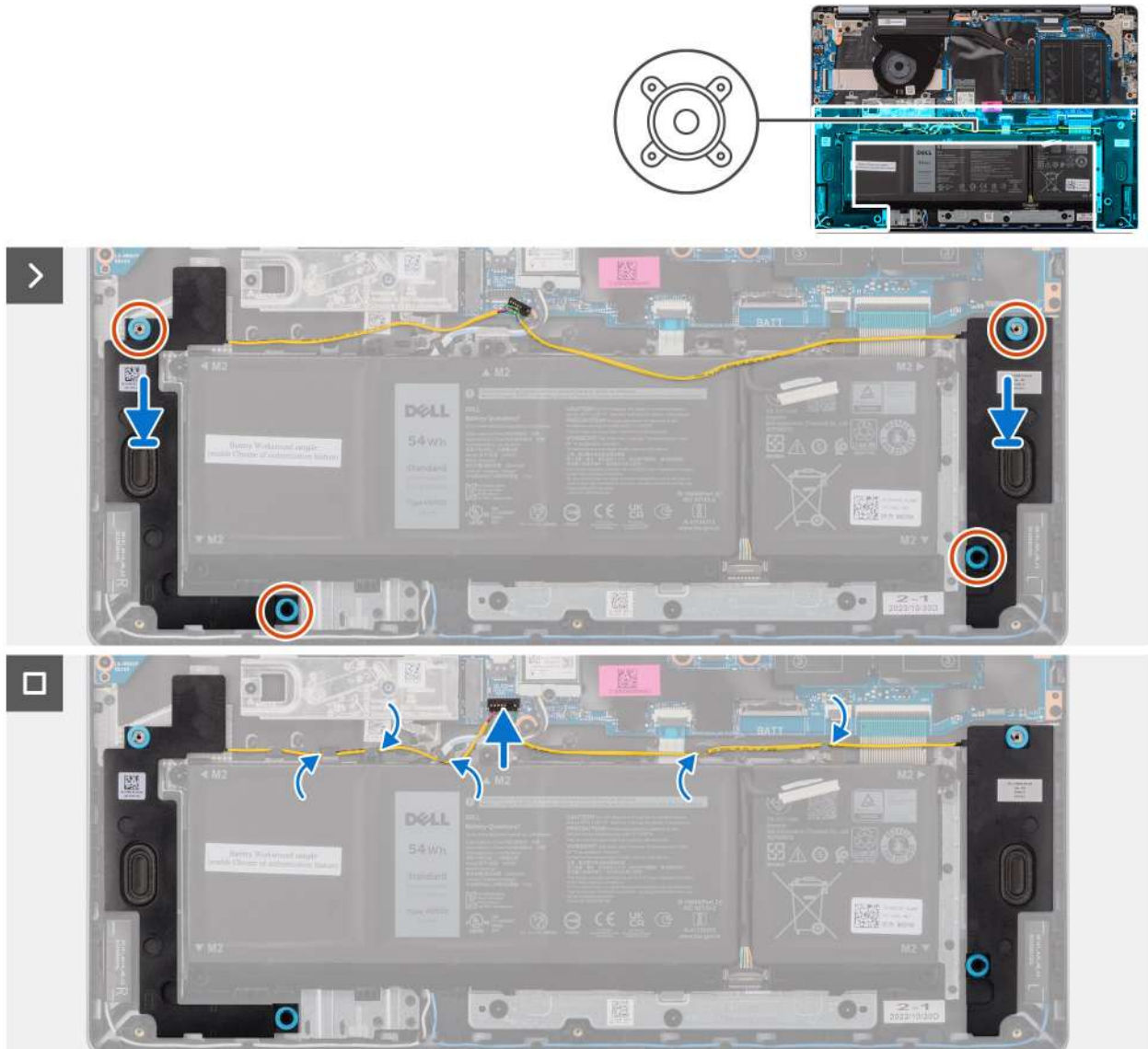

Figure 10. Installing the speakers

Steps

1. **NOTE:** If the rubber grommets are pushed out when removing the speakers, push them back in before replacing the speakers.

Using the alignment posts and rubber grommets, place the speakers in the slots on the palm-rest and keyboard assembly.

- NOTE:** Ensure that the alignment posts are threaded through the rubber grommets on the speakers. After placing speakers on the palm-rest and keyboard assembly, ensure that rubber grommets are seated into the slot and installed on the speakers properly.

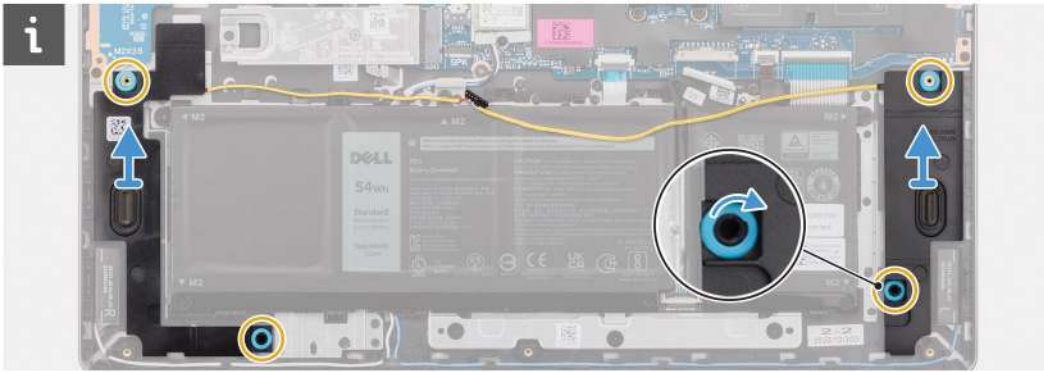

2. Route the speaker cable in the routing guides on the palm-rest and keyboard assembly.

i **NOTE:** The speaker cable must be routed through the routing guides to avoid damaging the speaker cable when installing the base cover.

3. Connect the speaker cable to its connector (SPK) on the system board.

Next steps

1. Install the [base cover](#).
2. Follow the procedure in [After working inside your computer](#).

Fan

Removing the fan

Prerequisites

1. Follow the procedure in [Before working inside your computer](#).
2. Remove the [base cover](#).

About this task

The following image indicates the location of the fan and provides a visual representation of the removal procedure.

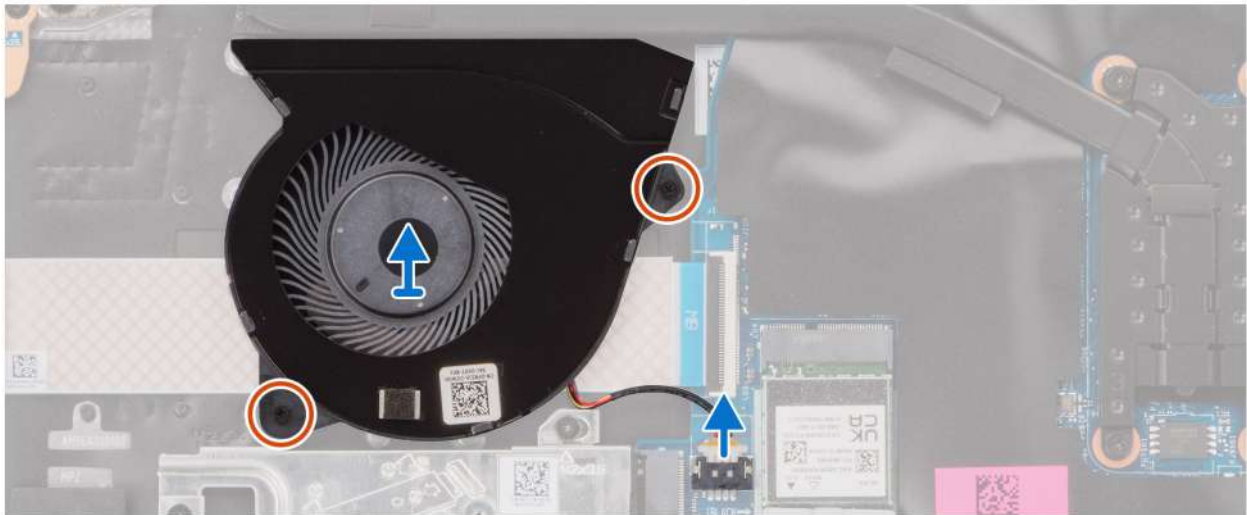

Figure 11. Removing the fan

Steps

1. Disconnect the fan cable from its connector (FAN) on the system board.
2. Remove the two screws (M2x5.5) that secure the fan to the palm-rest and keyboard assembly.
3. Lift the fan, along with the fan cable, off the palm-rest and keyboard assembly.

Installing the fan

Prerequisites

If you are replacing a component, remove the existing component before performing the installation procedure.

About this task

The following image indicates the location of the fan and provides a visual representation of the installation procedure.

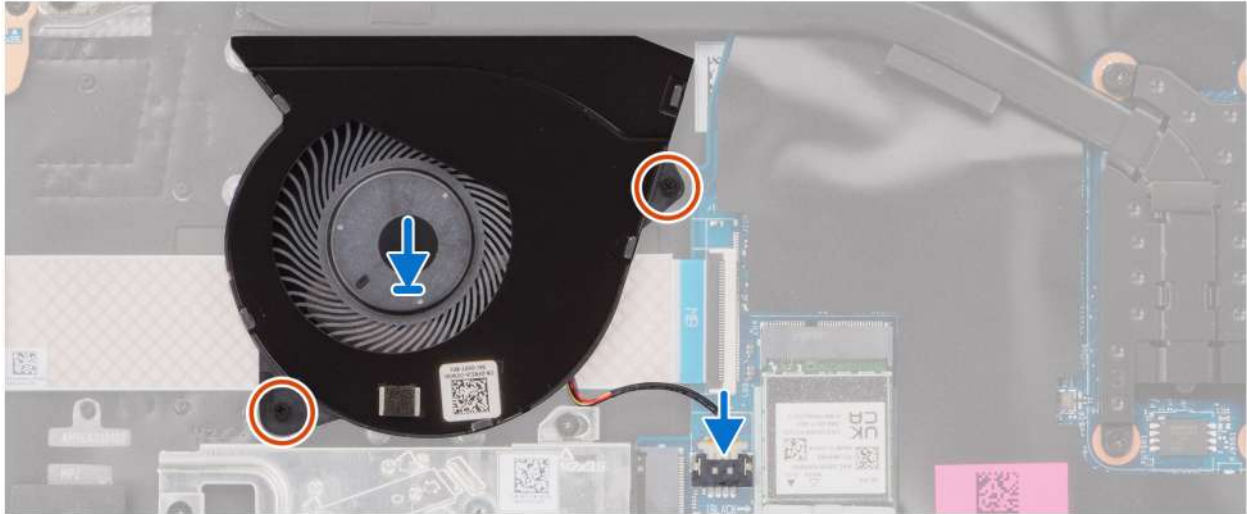

Figure 12. Installing the fan

Steps

1. Place and align the fan, along with fan cable, in the slot on the palm-rest and keyboard assembly.
2. Align the screw holes on the fan to the screw holes on the palm-rest and keyboard assembly.
3. Replace the two screws (M2x5.5) that secure the fan to the palm-rest and keyboard assembly.
4. Connect the fan cable to its connector (FAN) on the system board.

Next steps

1. Install the [base cover](#).
2. Follow the procedure in [After working inside your computer](#).

Battery

Rechargeable Li-ion battery precautions

WARNING:

- Exercise caution when handling rechargeable Li-ion batteries.
- Discharge the battery completely before removing it. Disconnect the AC power adapter from the computer and operate the computer solely on battery power—the battery is fully discharged when the computer no longer turns on when the power button is pressed.
- Do not crush, drop, mutilate, or penetrate the battery with foreign objects.
- Do not expose the battery to high temperatures, or disassemble battery packs and cells.
- Do not apply pressure to the surface of the battery.
- Do not bend the battery.
- Do not use tools of any kind to pry on or against the battery.

- To prevent accidental puncture or damage to the battery and other components, ensure that no screws are lost or misplaced during the servicing of the computer.
- Always purchase genuine batteries from [Dell Site](#) or authorized Dell partners and resellers.
- Swollen batteries should not be used and should be replaced and disposed properly. For guidelines on how to handle and replace swollen rechargeable Li-ion batteries, see [Handling swollen rechargeable Li-ion batteries](#).

Removing the battery

Prerequisites

1. Follow the procedure in [Before working inside your computer](#).
2. Remove the [base cover](#).

About this task

The following image indicates the location of the battery and provides a visual representation of the removal procedure.

- NOTE:** Dell 16 DC16256 (M) supports the following:
- 4-cell, 54 Wh, Lithium Ion Polymer, ExpressCharge Capable
 - 4-cell, 64 Wh, Lithium Ion Polymer, ExpressCharge Capable

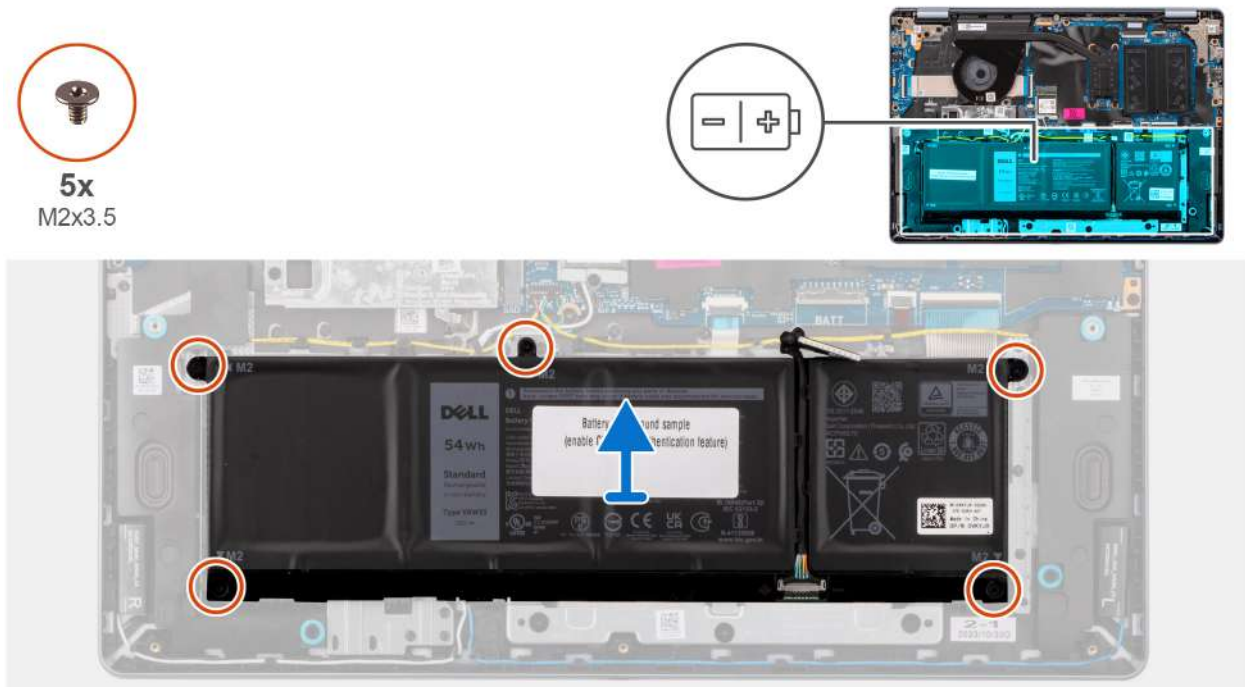

Figure 13. Removing the battery

Steps

1. Remove the five screws (M2x3.5) that secure the battery to the palm-rest and keyboard assembly.
2. Lift the battery, along with the battery cable, off the palm-rest and keyboard assembly.

Installing the battery

Prerequisites

If you are replacing a component, remove the existing component before performing the installation procedure.

About this task

The following image indicates the location of the battery and provides a visual representation of the installation procedure.

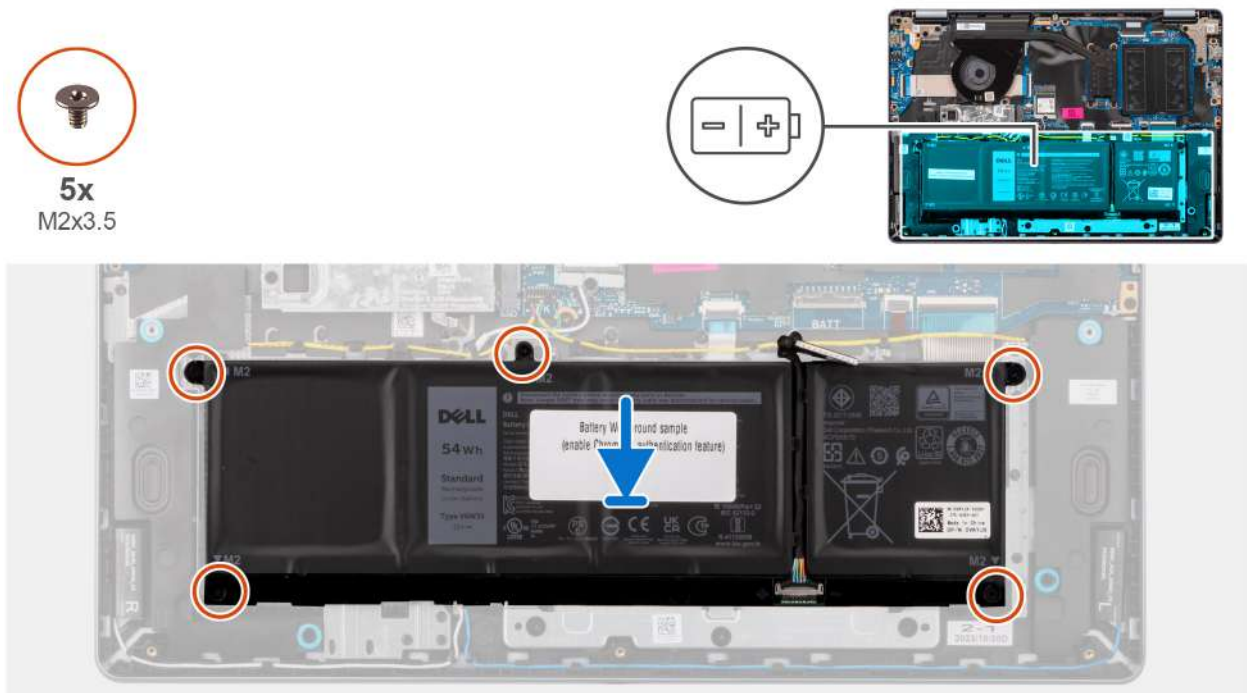

Figure 14. Installing the battery

Steps

1. Place the battery, along with the battery cable, in the slot on the palm-rest and keyboard assembly.
2. Align the screw holes on the battery to the screw holes on the palm-rest and keyboard assembly.

NOTE: While installing the battery, insert the cut-outs on the battery into the hooks on the palm-rest and keyboard assembly.



3. Replace the five screws (M2x3.5) that secure the battery to the palm-rest and keyboard assembly.

Next steps

1. Install the [base cover](#).
2. Follow the procedure in [After working inside your computer](#).

Battery cable

Installing the battery cable

Prerequisites

If you are replacing a component, remove the existing component before performing the installation procedure.

About this task

The following image indicates the location of the battery cable and provides a visual representation of the installation procedure.

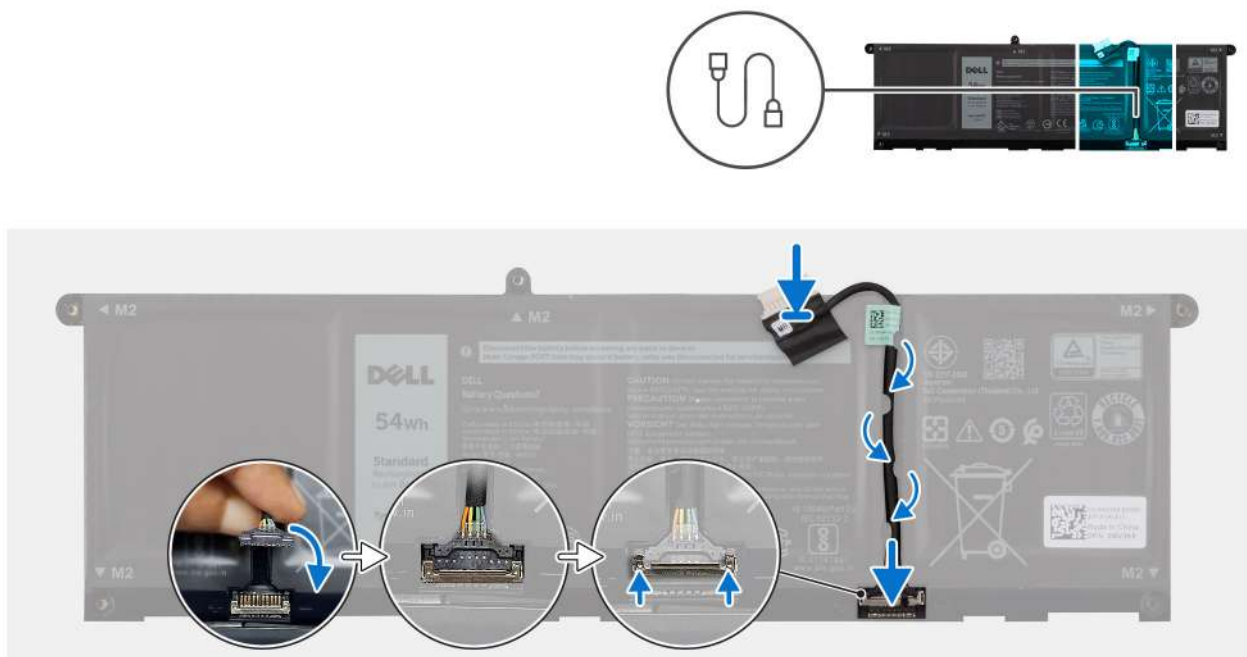

Figure 15. Connecting the battery cable

Steps

1. Connect the battery cable to the connector on the battery and close the latch.
2. Route the battery cable through the routing guides on the battery.

Next steps

1. Install the [battery](#).
2. Install the [base cover](#).
3. Follow the procedure in [After working inside your computer](#).

Removing the battery cable

Prerequisites

1. Follow the procedure in [Before working inside your computer](#).
2. Remove the [base cover](#).
3. Remove the [battery](#).

About this task

The following image indicates the location of the battery cable and provides a visual representation of the removal procedure.



Figure 16. Removing the battery cable

Steps

1. Remove the battery cable from the routing guides on the battery.
2. To disconnect the battery cable, first push the latch downward to release the connector, and then pull the connector upward to disconnect the cable from the battery.

CAUTION: DO NOT disconnect the battery cable from the battery by pulling the battery cable. This may damage the battery or the battery cable.



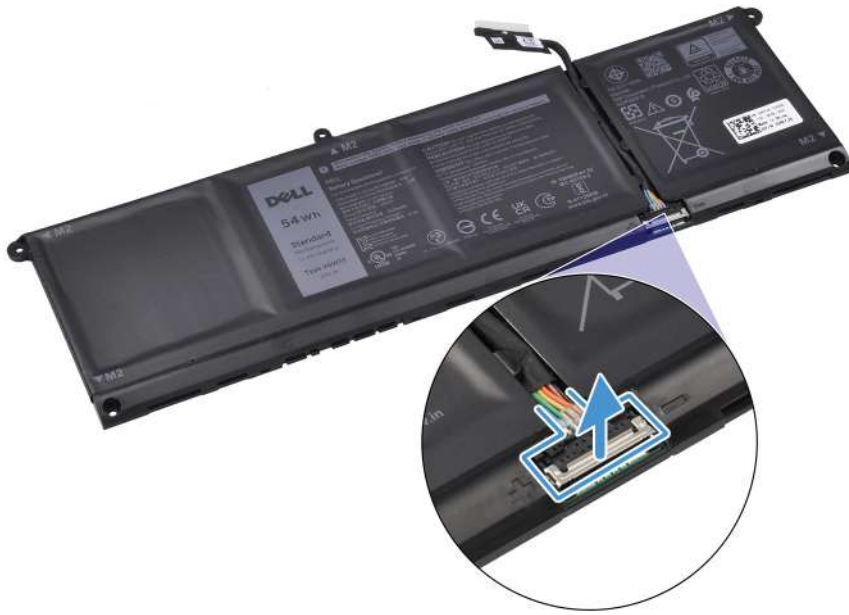

Removing and installing Field Replaceable Units (FRUs)

The replaceable components in this chapter are Field Replaceable Units (FRUs).

CAUTION: The information in this section is intended for authorized service technicians only.

CAUTION: To avoid any potential damage to the component or loss of data, ensure that an authorized service technician replaces the Field Replaceable Units (FRUs).

CAUTION: Dell Technologies recommends that these procedures be performed by trained technical repair specialists.

CAUTION: Your warranty does not cover damages that may occur during FRU repairs that are not authorized by Dell Technologies.

NOTE: The images in this document may differ from your computer depending on the configuration you ordered.

Heat sink

Removing the heat sink

CAUTION: The information in this section is intended for authorized service technicians only.

Prerequisites

1. Follow the procedure in [Before working inside your computer](#).
2. Remove the [base cover](#).

About this task

NOTE: The heat sink may become hot during normal operation. Allow sufficient time for the heat sink to cool before you touch it.

NOTE: For maximum cooling of the processor, do not touch the heat transfer areas on the heat sink. The oils in your skin can reduce the heat transfer capability of the thermal grease.

The following image indicates the location of the heat sink and provides a visual representation of the removal procedure.



Figure 17. Removing the heat sink

Steps

1. Loosen the four captive screws that secure the heat sink to the system board.
 - NOTE:** Loosen the four captive screws in the reverse sequential order indicated on the heat sink [4 → 3 → 2 → 1].
2. Lift the heat sink off the system board.

Installing the heat sink

CAUTION: The information in this section is intended for authorized service technicians only.

Prerequisites

If you are replacing a component, remove the existing component before performing the installation procedure.

About this task

NOTE: If either the system board or the heat sink is replaced, use the thermal grease that is provided in the kit to ensure that thermal conductivity is achieved.

The following image indicates the location of the heat sink and provides a visual representation of the installation procedure.



Figure 18. Installing the heat sink

Steps

1. Place the heat sink in the slot on the system board.
2. Align the screw holes on the heat sink to the screw holes on the system board.
3. Tighten the four captive screws that secure the heat sink to the system board.

NOTE: Tighten the four captive screws in the sequential order indicated on the heat sink [1 → 2 → 3 → 4].

Next steps

1. Install the [base cover](#).
2. Follow the procedure in [After working inside your computer](#).

Touchpad

Removing the touchpad assembly

CAUTION: The information in this section is intended for authorized service technicians only.

Prerequisites

1. Follow the procedure in [Before working inside your computer](#).
2. Remove the [base cover](#).
3. Remove the [battery](#).

About this task

The following images indicate the location of the touchpad assembly and provide a visual representation of the removal procedure.

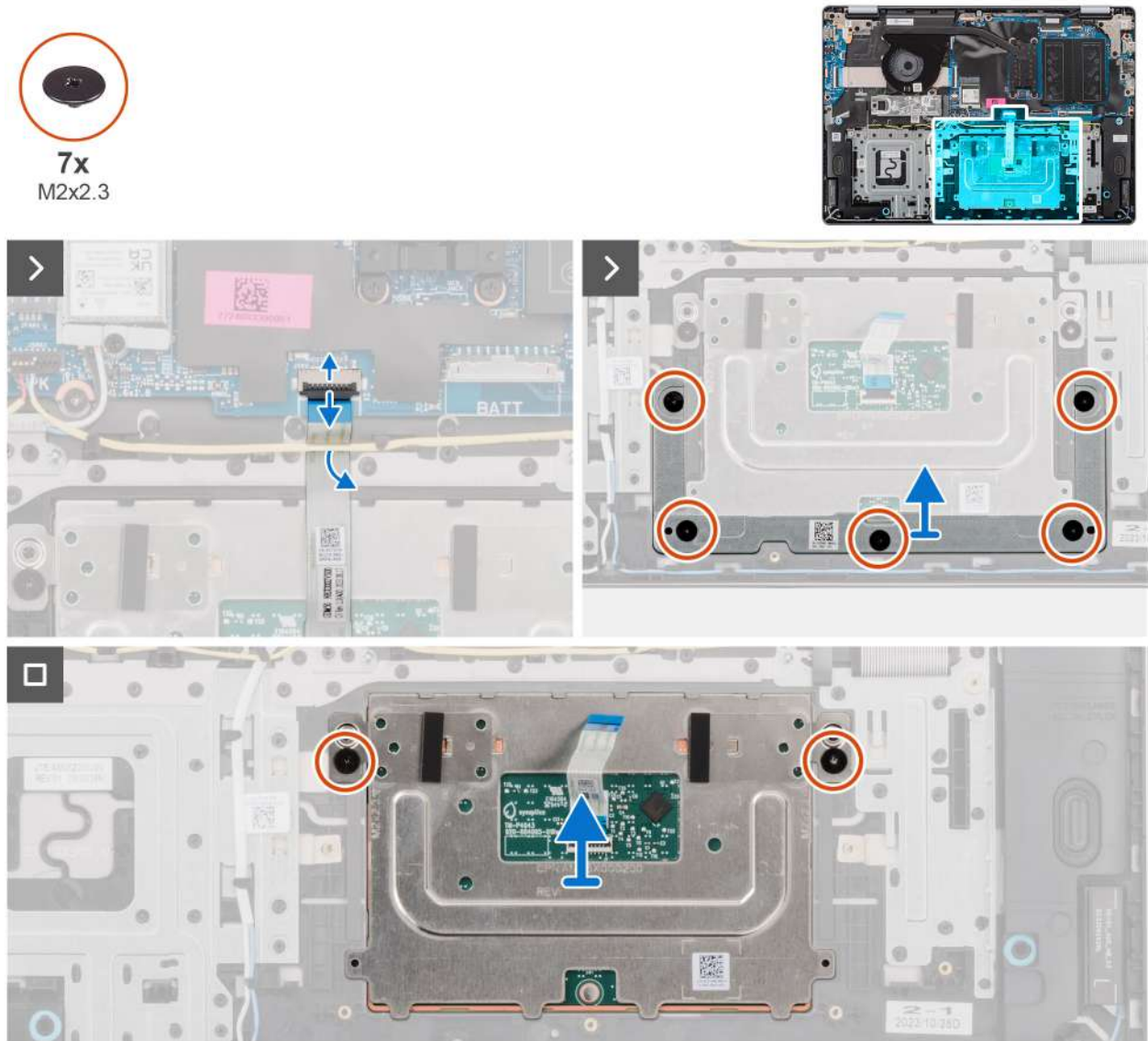

Figure 19. Removing the touchpad assembly

Steps

1. Open the latch and disconnect the touchpad cable from its connector (TP) on the system board.
2. Remove the five screws (M2x2.3) that secure the touchpad bracket to the palm-rest and keyboard assembly.
3. Slide and lift the touchpad bracket off the touchpad assembly.
4. Remove the two screws (M2x2.3) that secure the touchpad assembly to the palm-rest and keyboard assembly.
5. Lift the touchpad assembly, along with the touchpad cable, off the palm-rest and keyboard assembly.

Installing the touchpad assembly

CAUTION: The information in this section is intended for authorized service technicians only.

Prerequisites

If you are replacing a component, remove the existing component before performing the installation procedure.

About this task

NOTE: Ensure that the touchpad is aligned with the guides available on the palm-rest and keyboard assembly, and the gap on either sides of the touchpad is equal.

The following images indicate the location of the touchpad assembly and provide a visual representation of the installation procedure.

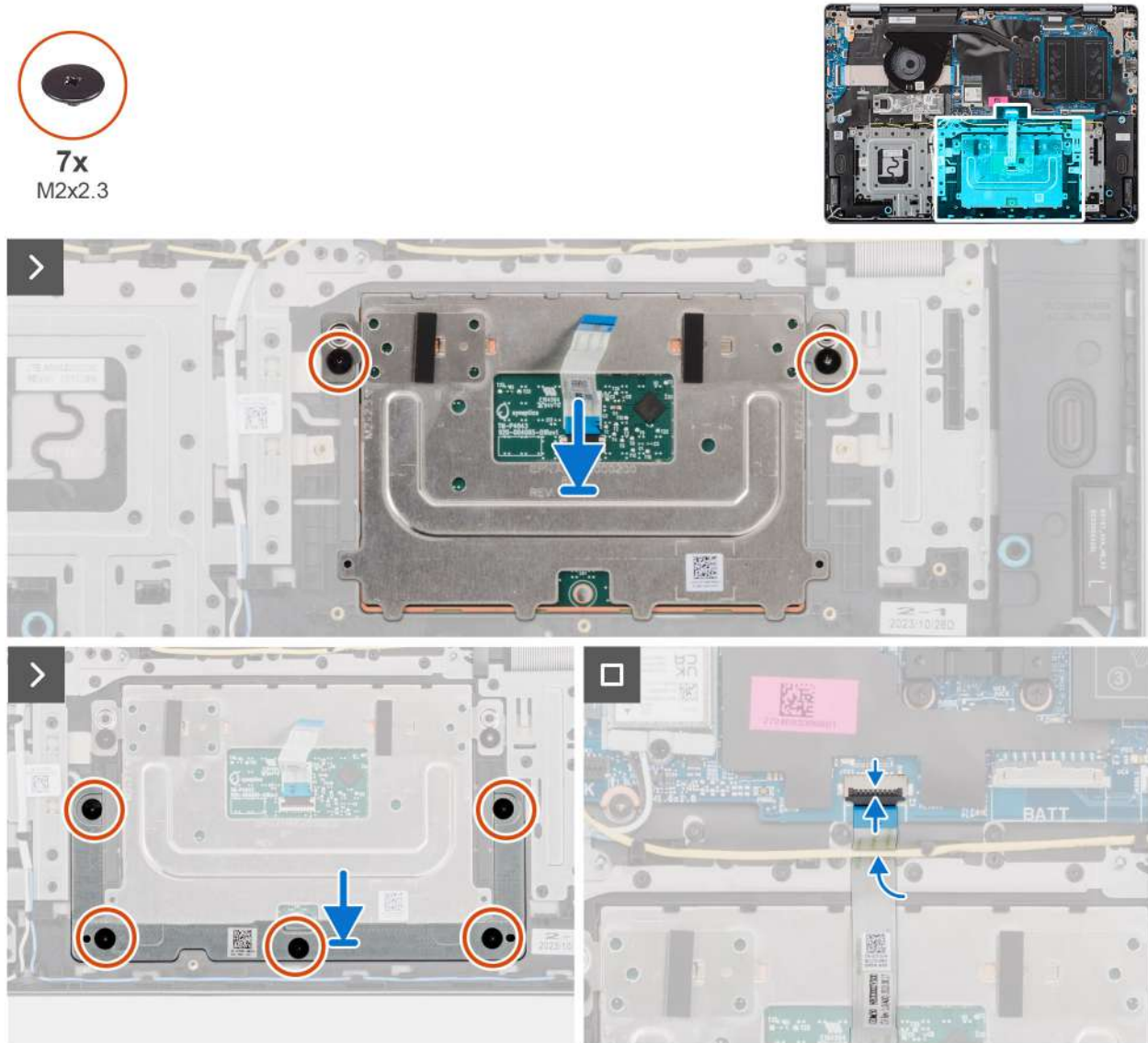

Figure 20. Installing the touchpad assembly

Steps

1. Align and place the touchpad, along with the touchpad cable, in the slot on the palm-rest and keyboard assembly.
2. Replace the two screws (M2x2.3) that secure the touchpad assembly to the palm-rest and keyboard assembly.
3. Place the touchpad bracket in the slot on the palm-rest and keyboard assembly.
4. Align the screw holes on the touchpad bracket to the screw holes on the palm-rest and keyboard assembly.
5. Replace the five screws (M2x2.3) that secure the touchpad bracket to the palm-rest and keyboard assembly.
6. Connect the touchpad cable to its connector (TP) on the system board and close the latch.

NOTE: Route the touchpad cable underneath the speaker cable to secure it properly before connecting the touchpad cable to its connector (TP) on the system board.

Next steps

1. Install the [battery](#).
2. Install the [base cover](#).
3. Follow the procedure in [After working inside your computer](#).

Display assembly

Removing the display assembly

 **CAUTION:** The information in this section is intended for authorized service technicians only.

 **CAUTION:** The maximum operating angle for the display-panel hinge is 135 degrees.

Prerequisites

1. Follow the procedure in [Before working inside your computer](#).
2. Remove the [base cover](#).

About this task

The following images indicate the location of the display assembly and provide a visual representation of the removal procedure.



5x
M2.5x5

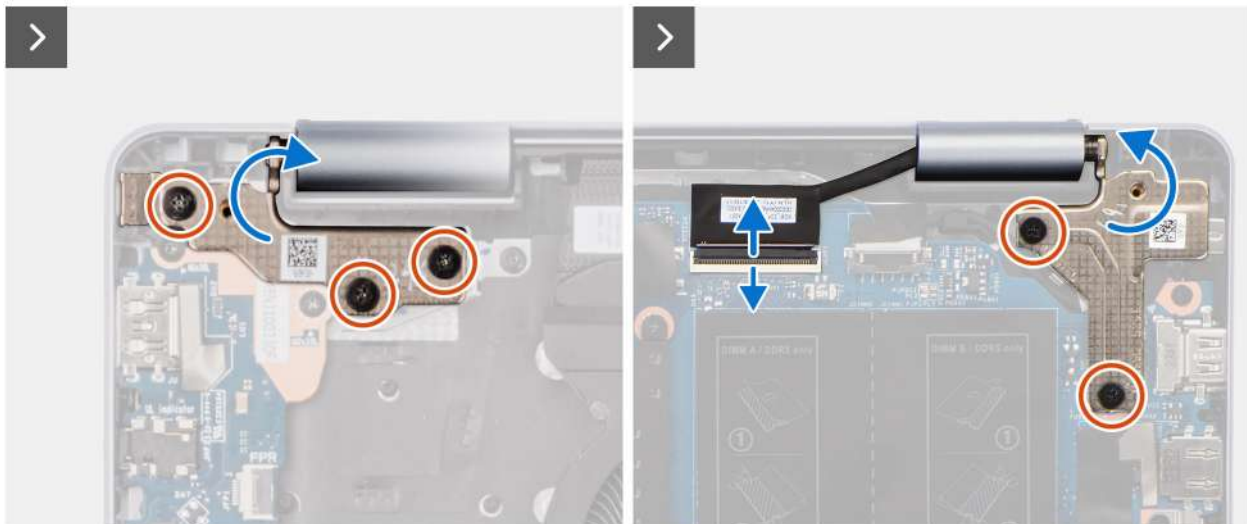

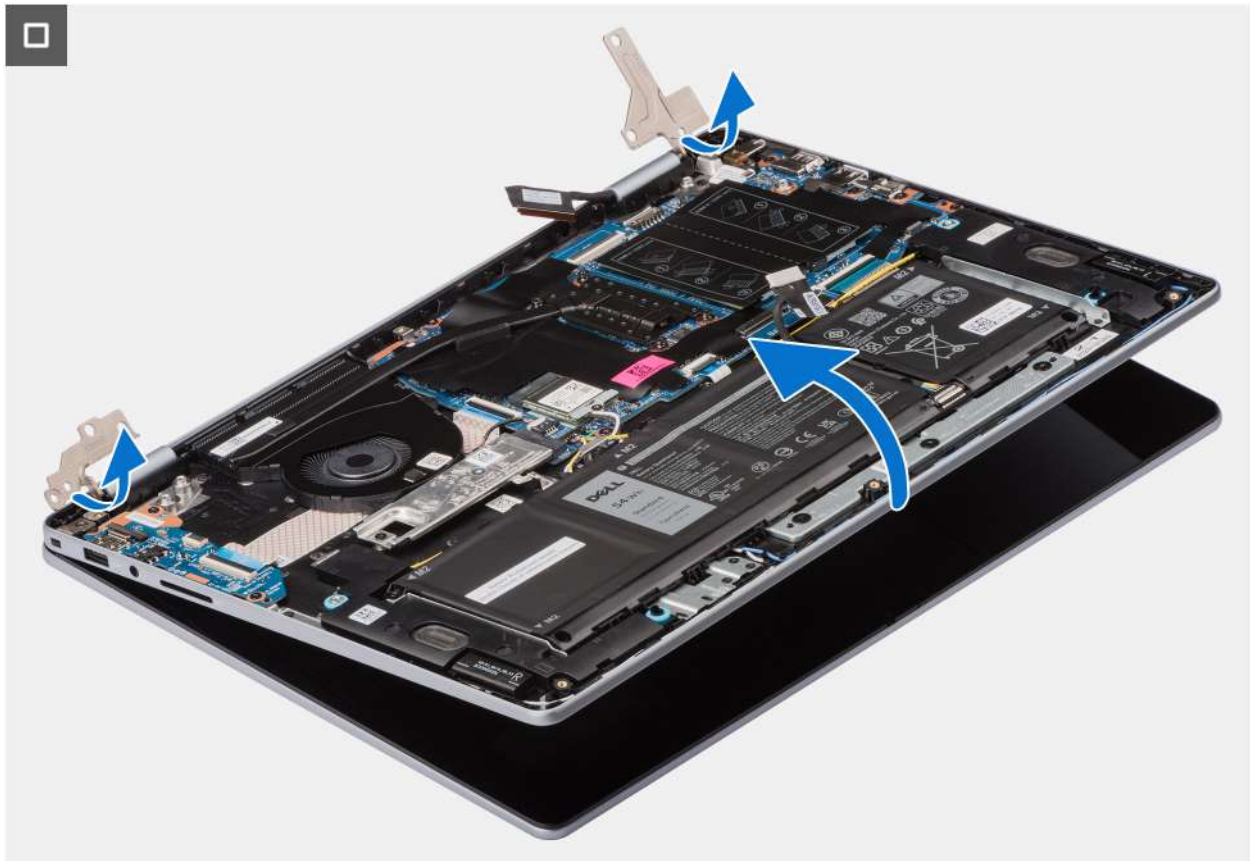

Figure 21. Removing the display assembly

Steps

1. Remove the five screws (M2.5x5) that secure the display hinges to the palm-rest and keyboard assembly.
2. Disconnect the display cable from its connector (eDP) on the system board.
3. Remove the display cable from the routing guides on the palm-rest and keyboard assembly.
4. Open the hinges to a 90-degree angle and place the computer on the edge of a flat surface.
5. Lift the palm-rest and keyboard assembly at an angle to free it from the hinges and remove it from the display assembly.

i **NOTE:** The display assembly is a Hinge-Up Design (HUD) assembly and cannot be further disassembled. If any components in the display assembly malfunction and requires replacement, the entire display assembly has to be replaced.

i **NOTE:** The power-adaptor port is secured in place by the left hinge. There is no screw, tape, or adhesive securing the power-adaptor port to the palm-rest. Technicians should ensure that the power-adaptor port has not fallen out when the left hinge is removed.

Installing the display assembly

⚠ CAUTION: The information in this section is intended for authorized service technicians only.

⚠ CAUTION: The maximum operating angle for the display-panel hinge is 135 degrees.

Prerequisites

If you are replacing a component, remove the existing component before performing the installation procedure.

About this task

NOTE: Ensure that the display hinges are opened to the maximum before replacing the display assembly on the palm-rest and keyboard assembly.

The following images indicate the location of the display assembly and provide a visual representation of the installation procedure.



5x
M2.5x5

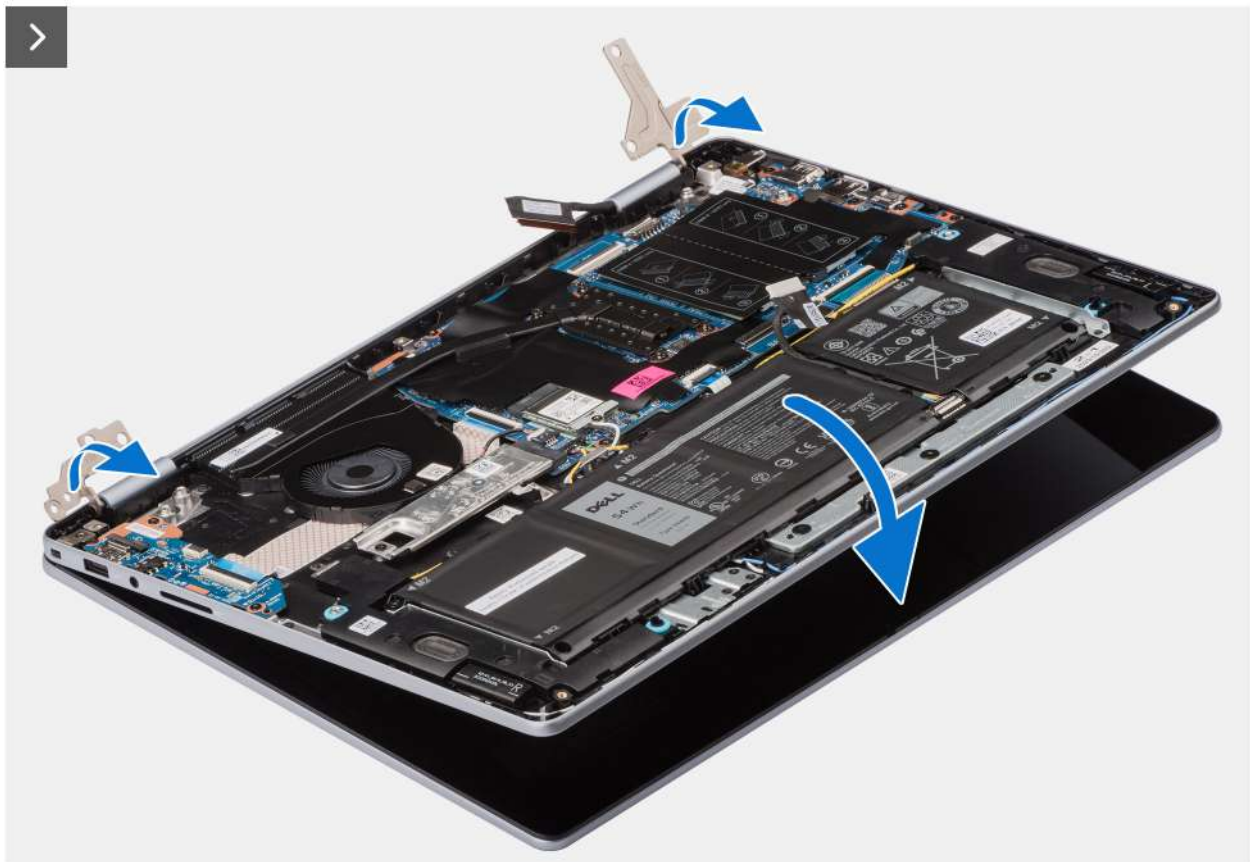

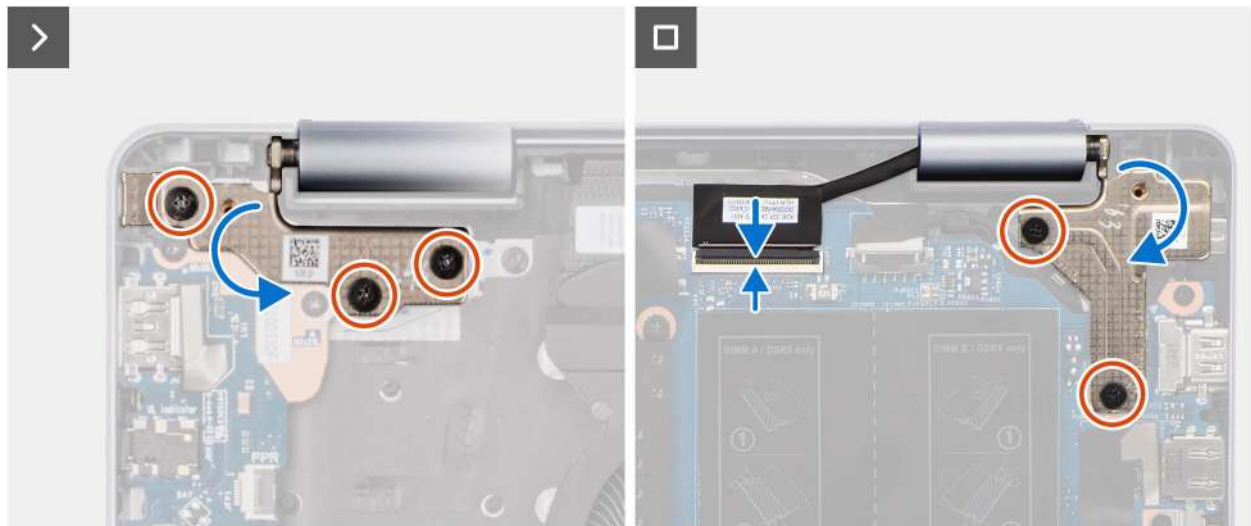

Figure 22. Installing the display assembly

Steps

1. Place the display assembly on a clean and flat surface.
2. Slide the palm-rest and keyboard assembly at an angle and place the palm-rest and keyboard assembly on the display assembly.
 - NOTE:** The power-adaptor port is secured in place by the left hinge. There is no screw, tape, or adhesives securing the power-adaptor port to the palm-rest. Technicians should ensure that the power-adaptor port has not fallen out when the left hinge is removed.
3. Gently press down on the hinges to align the screw holes on the hinges with the screw holes on the palm-rest and keyboard assembly.
4. Connect the display cable to its connector (eDP) on the system board.
5. Replace the five screws (M2.5x5) that secure the display assembly to the palm-rest and keyboard assembly.

Next steps

1. Install the [base cover](#).
2. Follow the procedure in [After working inside your computer](#).

I/O-board cable

Removing the I/O-board cable

CAUTION: The information in this section is intended for authorized service technicians only.

Prerequisites

1. Follow the procedure in [Before working inside your computer](#).
2. Remove the [base cover](#).
3. Remove the [fan](#).

About this task

The following image indicates the location of the I/O-board cable and provides a visual representation of the removal procedure.

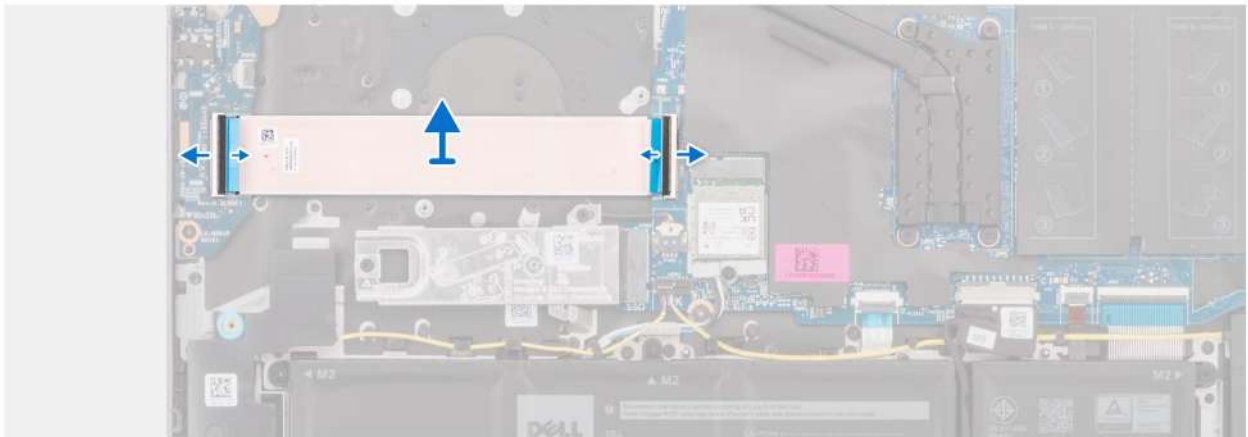

Figure 23. Removing the I/O-board cable

Steps

1. Open the latch and disconnect the I/O-board cable from its connector (IO) on the system board.
2. Open the latch and disconnect the I/O-board cable from its connector on the I/O board.
3. Remove the I/O-board cable from the palm-rest and keyboard assembly.

Installing the I/O-board cable

CAUTION: The information in this section is intended for authorized service technicians only.

Prerequisites

If you are replacing a component, remove the existing component before performing the installation procedure.

About this task

The following image indicates the location of the I/O-board cable and provides a visual representation of the installation procedure.

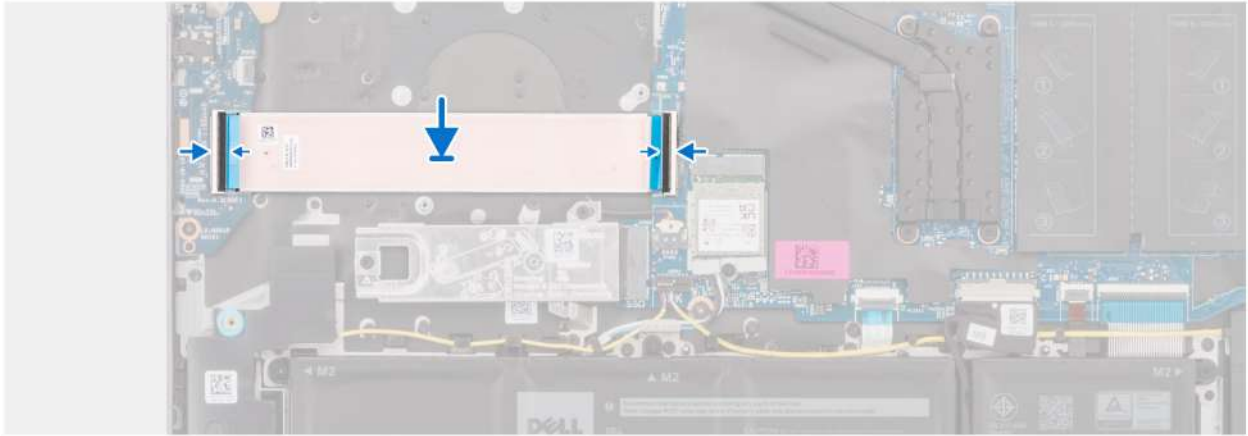

Figure 24. Installing the I/O-board cable

Steps

1. Place the I/O-board cable on the palm-rest and keyboard assembly.
2. Connect the I/O-board cable to its connector on the I/O board and close the latch.
3. Connect the I/O-board cable to its connector (IO) on the system board and close the latch.

Next steps

1. Install the [fan](#).
2. Install the [base cover](#).
3. Follow the procedure in [After working inside your computer](#).

I/O board

Removing the I/O board

CAUTION: The information in this section is intended for authorized service technicians only.

Prerequisites

1. Follow the procedure in [Before working inside your computer](#).
2. Remove the [base cover](#).

About this task

The following images indicate the location of the I/O board and provide a visual representation of the removal procedure.

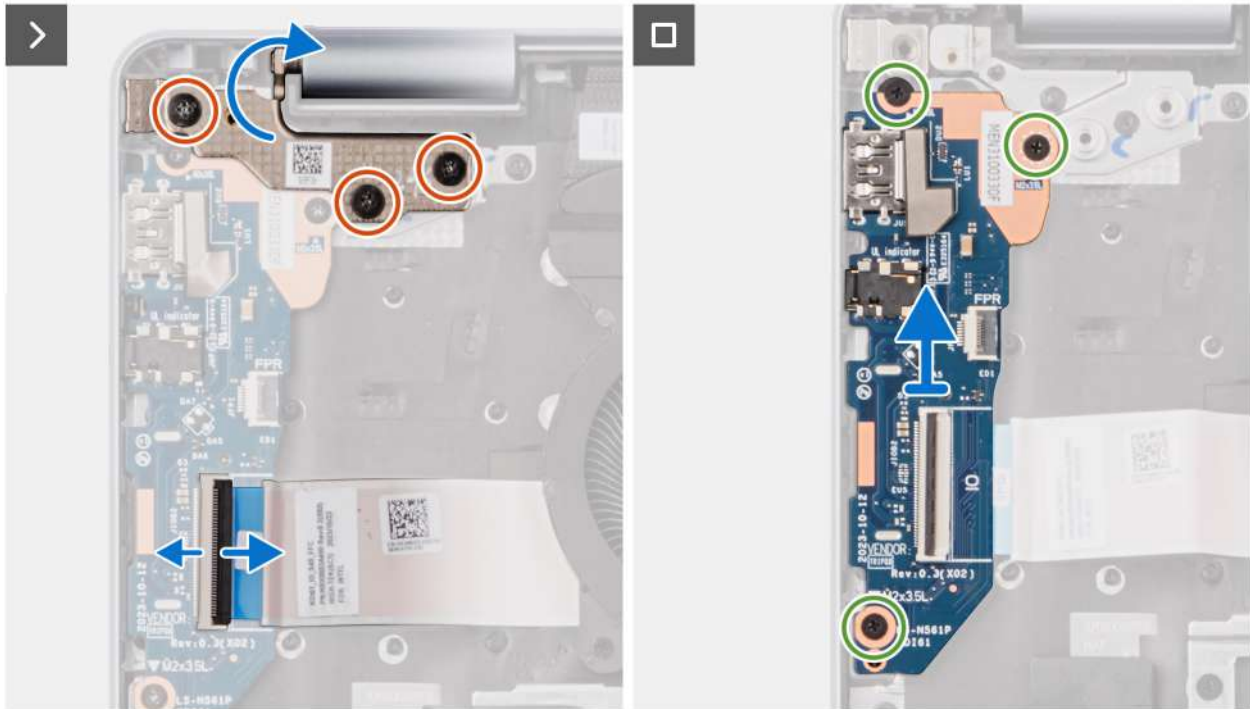

Figure 25. Removing the I/O board

Steps

1. Remove the three screws (M2.5x5) that secure the hinge to the palm-rest and keyboard assembly.
2. Pry open the hinge away from the palm-rest and keyboard assembly to access the I/O board.
3. Open the latch and disconnect the I/O-board cable from its connector on the I/O board.
4. Open the latch and disconnect the fingerprint reader cable from the I/O board.

NOTE: This step applies only to computers shipped with a fingerprint reader installed.

5. Remove the three screws (M2x3.5) that secure the I/O board to the palm-rest and keyboard assembly.
6. Carefully slide and remove the I/O board at angle, from the palm-rest and keyboard assembly.

Installing the I/O board

CAUTION: The information in this section is intended for authorized service technicians only.

Prerequisites

If you are replacing a component, remove the existing component before performing the installation procedure.

About this task

The following images indicate the location of the I/O board and provide a visual representation of the installation procedure.

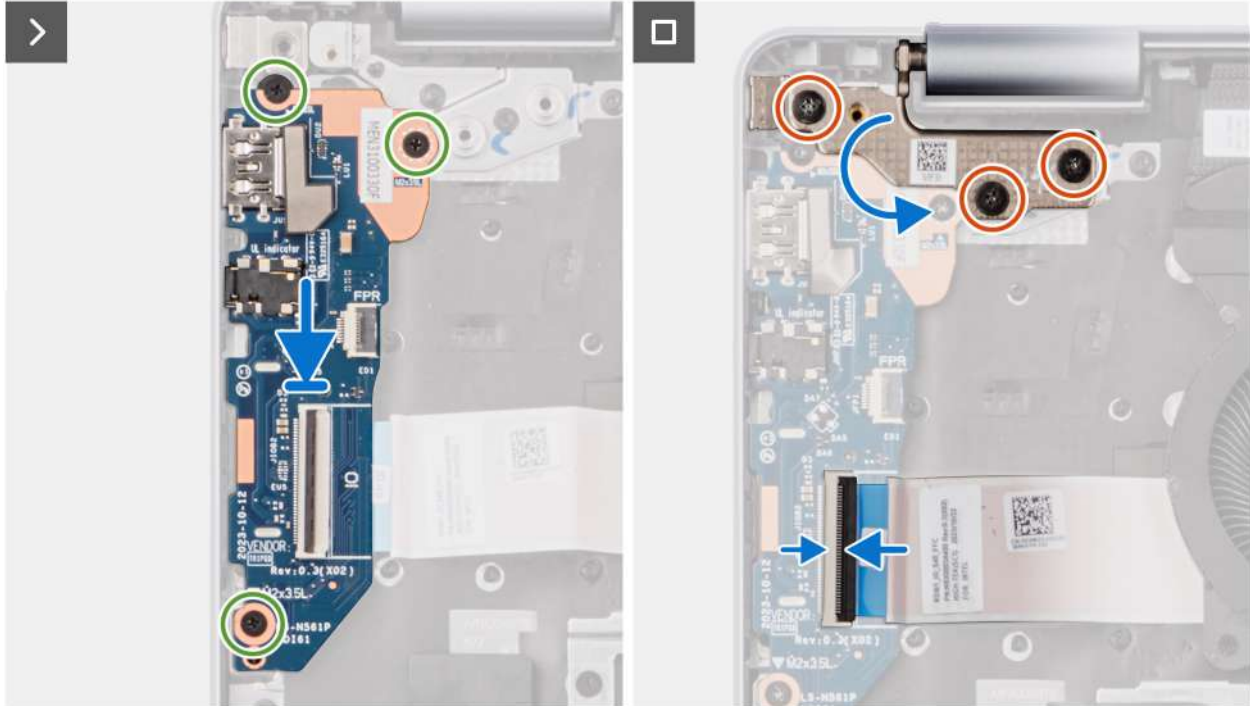

Figure 26. Installing the I/O board

Steps

1. Align the ports on the I/O board to the port openings on the palm-rest and keyboard assembly.
2. Carefully slide and place the I/O board at an angle, on the palm-rest and keyboard assembly.
3. Align the screw holes on the I/O board to the screw holes on the palm-rest and keyboard assembly.
4. Replace the three screws (M2x3.5) that secure the I/O board to the palm-rest and keyboard assembly.
5. Connect the fingerprint reader cable to the connector on the I/O board and close the latch.

NOTE: This step applies only to computers shipped with a fingerprint reader installed.

6. Connect the I/O-board cable to the connector on the I/O board and close the latch.
7. Close the display hinge downwards to align the screw holes of the left hinge to the screw holes on the palm-rest and keyboard assembly.
8. Replace the three screws (M2.5x5) that secure the hinge to the palm-rest and keyboard assembly.

Next steps

1. Install the [base cover](#).
2. Follow the procedure in [After working inside your computer](#).

Power button

Removing the power button

CAUTION: The information in this section is intended for authorized service technicians only.

Prerequisites

1. Follow the procedure in [Before working inside your computer](#).
2. Remove the [base cover](#).
3. Remove the [I/O board](#).

About this task

The following image indicates the location of the power button and provides a visual representation of the removal procedure.

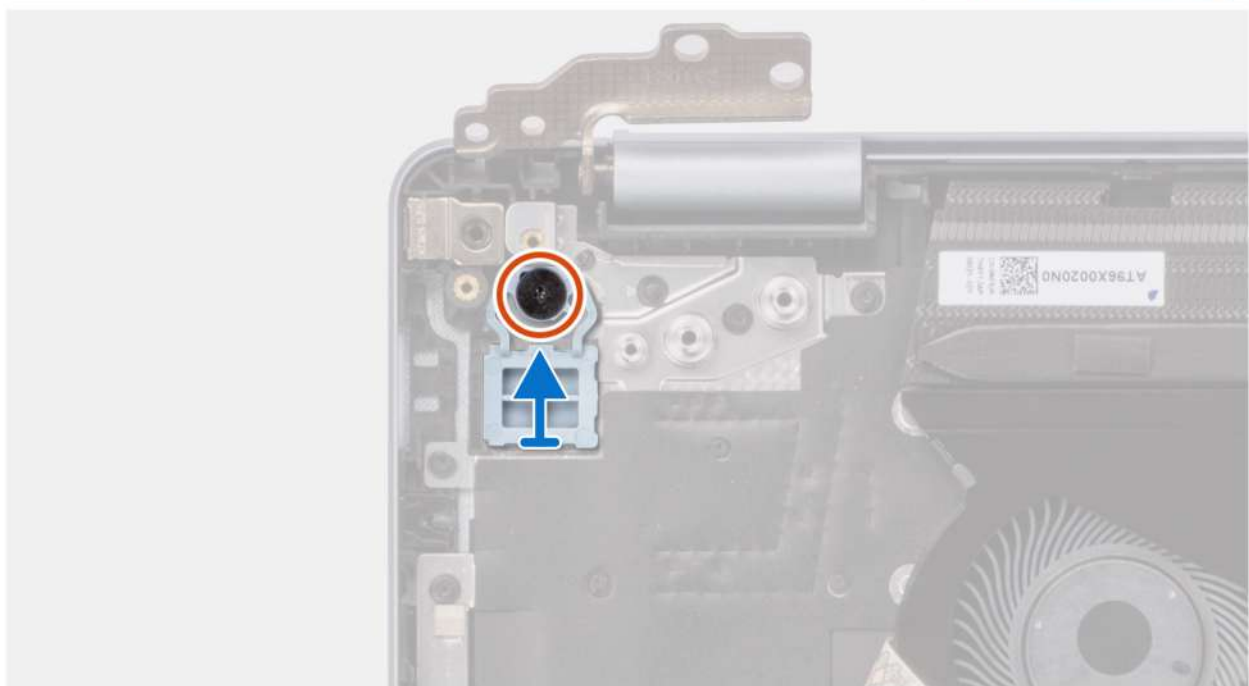

Figure 27. Removing the power button

Steps

1. Remove the screw (M2x2.3) that secures the power button to the palm-rest and keyboard assembly.
2. Lift the power button off the palm-rest and keyboard assembly.

Installing the power button

CAUTION: The information in this section is intended for authorized service technicians only.

Prerequisites

If you are replacing a component, remove the existing component before performing the installation procedure.

About this task

The following image indicates the location of the power button and provides a visual representation of the installation procedure.

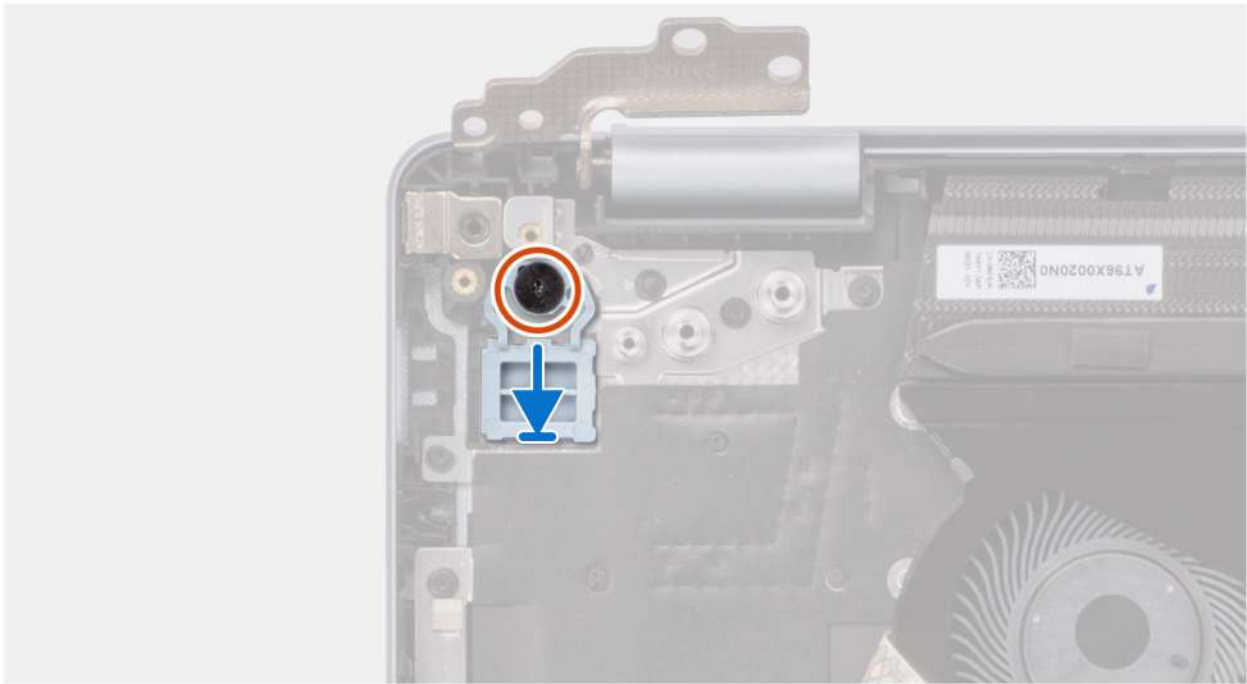

Figure 28. Installing the power button

Steps

1. Place the power button in the slot on the palm-rest and keyboard assembly.
2. Align the screw hole on the power button to the screw hole on the palm-rest and keyboard assembly.
3. Replace the screw (M2x2.3) that secure the power button to the palm-rest and keyboard assembly.

Next steps

1. Install the [I/O board](#).
2. Install the [base cover](#).
3. Follow the procedure in [After working inside your computer](#).

Power button with optional fingerprint reader

Removing the power button with optional fingerprint reader

CAUTION: The information in this section is intended for authorized service technicians only.

Prerequisites

1. Follow the procedure in [Before working inside your computer](#).
2. Remove the [base cover](#).
3. Remove the [I/O board](#).

About this task

NOTE: This procedure applies only to computers shipped with a power button with fingerprint reader installed.

The following image indicates the location of the power button with the optional fingerprint reader and provides a visual representation of the removal procedure.



1x
M2x2.3

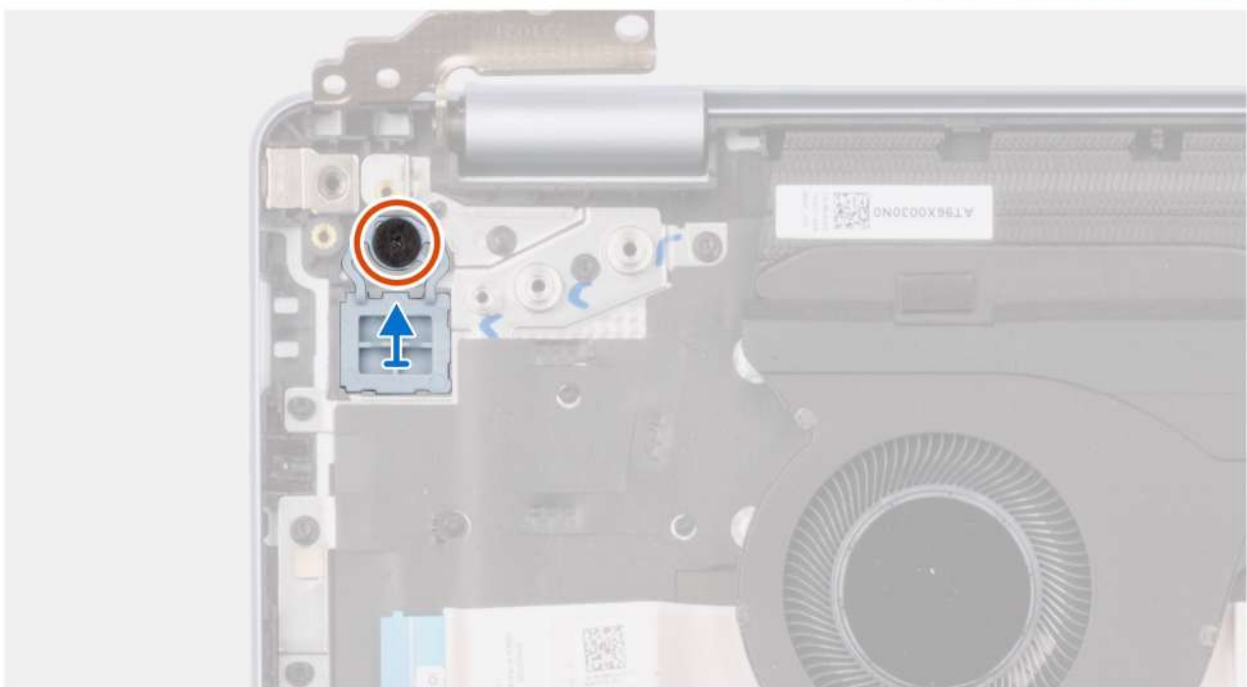

Figure 29. Removing the power button with optional fingerprint reader

Steps

1. Peel the fingerprint-reader cable from the palm-rest and keyboard assembly.
2. Remove the screw (M2x2.3) that secures the power button with fingerprint-reader cable to the palm-rest and keyboard assembly.
3. Lift the power button, along with fingerprint-reader cable, off the slot on the palm-rest and keyboard assembly.

Installing the power button with optional fingerprint reader

CAUTION: The information in this section is intended for authorized service technicians only.

Prerequisites

If you are replacing a component, remove the existing component before performing the installation procedure.

About this task

NOTE: This procedure applies only to computers shipped with a power button with fingerprint reader installed.

The following image indicates the location of the power button with the optional fingerprint reader and provides a visual representation of the installation procedure.

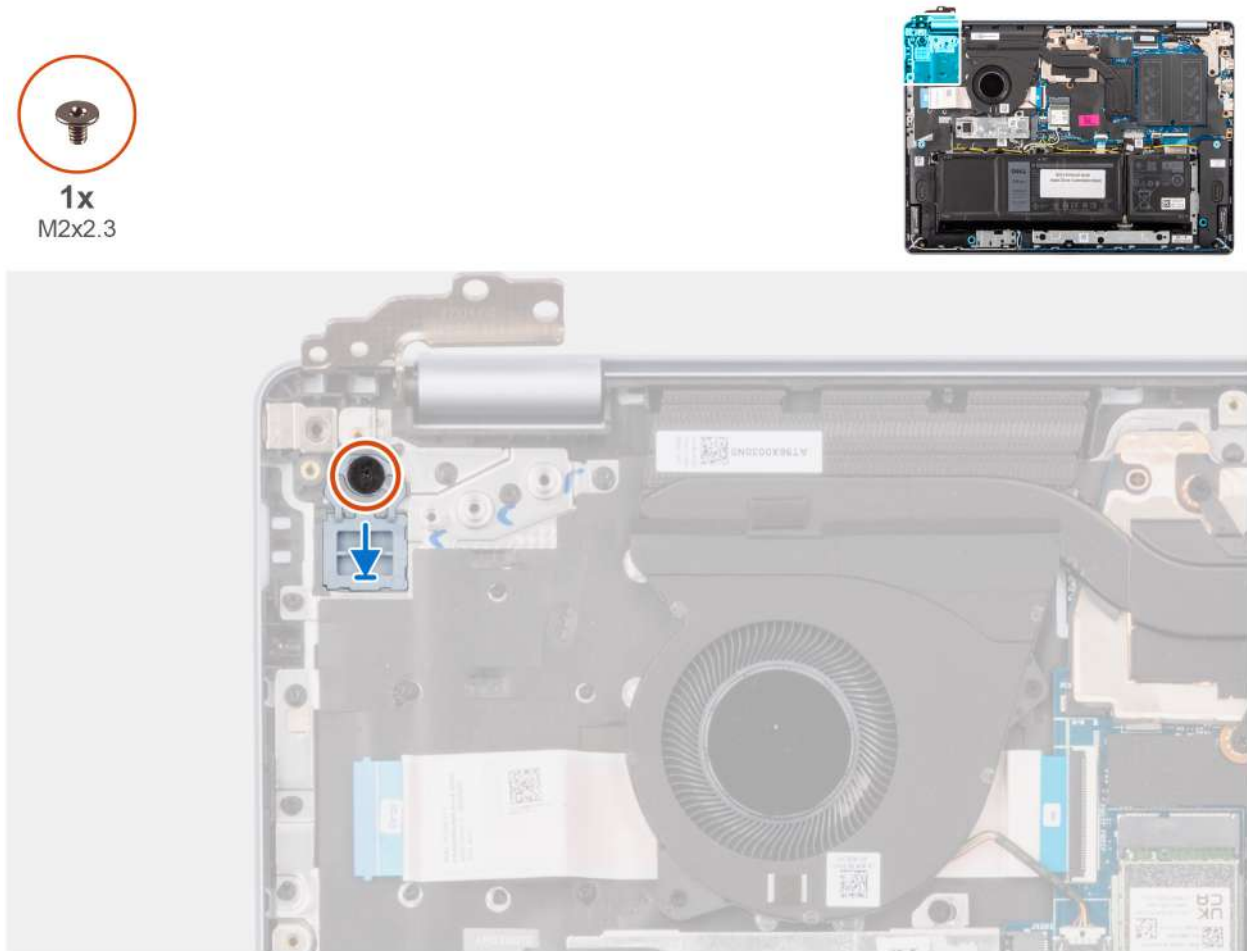

Figure 30. Installing the power button with optional fingerprint reader

Steps

1. Place the power button along with fingerprint-reader cable in the slot on the palm-rest and keyboard assembly.
2. Align the screw hole on the power button to the screw hole on the palm-rest and keyboard assembly.
3. Replace the screw (M2x2.3) that secure the power button with fingerprint-reader cable to the palm-rest and keyboard assembly.
4. Adhere the fingerprint-reader cable to the palm-rest and keyboard assembly.

NOTE: When installing the power button, align the fingerprint reader cable to the mark at the right of the power button. The grounding tape on the top side of the cable must be adhered to the keyboard plate.



Figure 31. Installing the power button - Grounding tape adhered to keyboard plate

Next steps

1. Install the [I/O board](#).
2. Install the [base cover](#).
3. Follow the procedure in [After working inside your computer](#).

Power-adapter port

Removing the power-adapter port

CAUTION: The information in this section is intended for authorized service technicians only.

Prerequisites

1. Follow the procedure in [Before working inside your computer](#).
2. Remove the [base cover](#).

About this task

The following images indicate the location of the power-adapter port and provide a visual representation of the removal procedure.

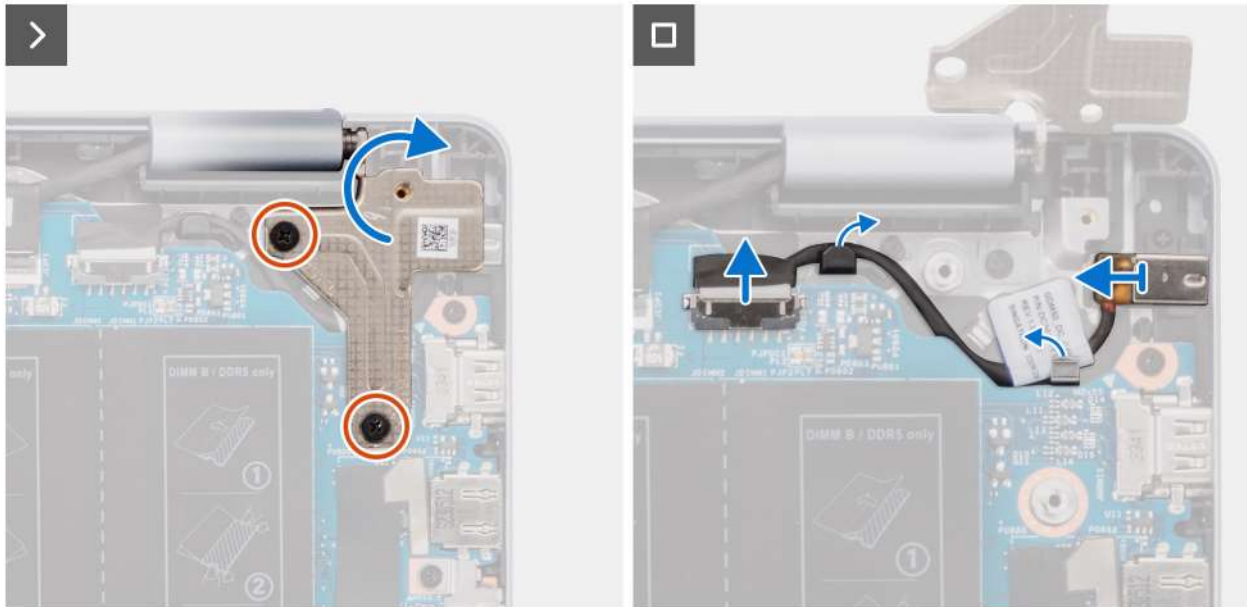

Figure 32. Removing the power-adapter port

Steps

1. Remove the two screws (M2.5x5) that secure the hinge to the system board and the palm-rest and keyboard assembly.
2. Pry open the hinge away from the palm-rest and keyboard assembly to access the power-adapter port.
3. Disconnect the power-adapter port cable from its connector (DCIN) on the system board.
4. Remove the power-adapter port cable through the guide on the palm-rest and keyboard assembly.
5. Remove the power-adapter port from the slot on the palm-rest and keyboard assembly.

NOTE: The power-adapter port is secured in place by the hinge. There is no screw, tape, or adhesive securing the power-adapter port to the palm-rest. Technicians should ensure that the power-adapter port has not fallen out when the right hinge is removed.

Installing the power-adapter port

CAUTION: The information in this section is intended for authorized service technicians only.

Prerequisites

If you are replacing a component, remove the existing component before performing the installation procedure.

About this task

The following images indicate the location of the power-adapter port and provide a visual representation of the installation procedure.

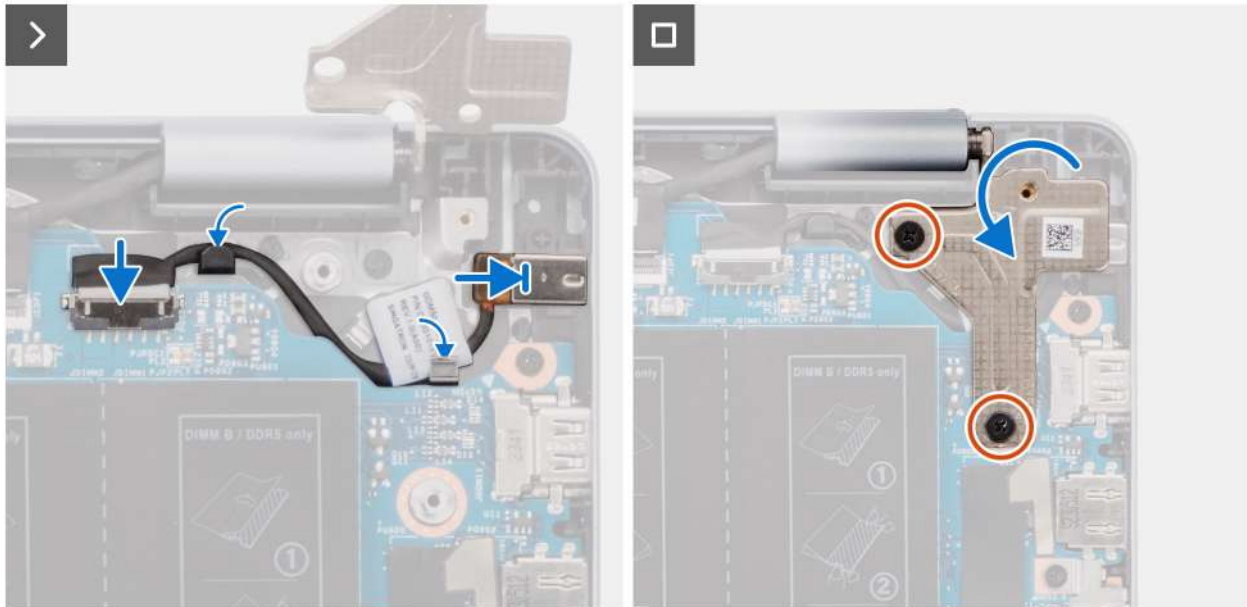

Figure 33. Installing the power-adapter port

Steps

1. Align and place the power-adapter port in the slot on the palm-rest and keyboard assembly.
 - NOTE:** The power-adapter port is secured in place by the hinge. There is no screw, tape, or adhesive securing the power-adapter port to the palm-rest. Technicians should ensure that the power-adapter port has not fallen out when the right hinge is removed.
2. Route the power-adapter port cable through the guide on the palm-rest and keyboard assembly.
3. Connect the power-adapter port cable to its connector (DCIN) on the system board.
4. Press the hinge down to align the screw holes on the hinge to the screw holes on the system board and the palm-rest and keyboard assembly.
5. Replace the two screws (M2.5x5) that secure the hinge to the system board and the palm-rest and keyboard assembly.

Next steps

1. Install the [base cover](#).
2. Follow the procedure in [After working inside your computer](#).

System board

Removing the system board

CAUTION: The information in this section is intended for authorized service technicians only.

Prerequisites

1. Follow the procedure in [Before working inside your computer](#).
2. Remove the [base cover](#).
3. Remove the [memory module](#).
4. Remove the [solid-state drive](#).
5. Remove the [wireless card](#).
6. Remove the [fan](#).
7. Remove the [heat sink](#).

NOTE: When removing the system board to replace/access other parts, the system board can be removed with the heat sink attached to it in order to simplify the procedure and preserve the thermal bond between the system board and heat sink.

About this task

The following image indicates the connectors on your system board.

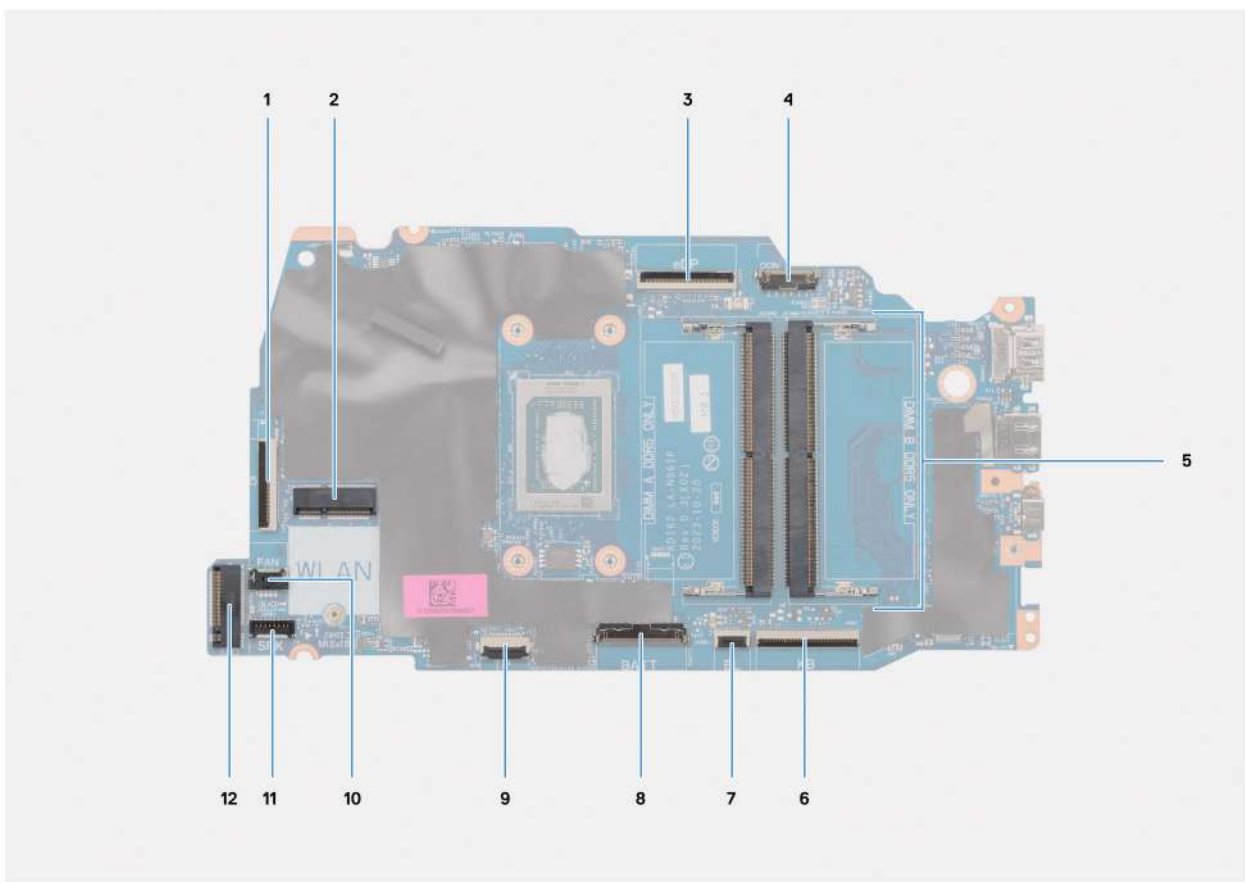

Figure 34. System board overview

1. I/O-board cable connector (IO)
2. Wireless card slot (WLAN)
3. Display cable connector (eDP)
4. Power-adaptor port cable connector (DCIN)
5. Memory slots x2 (DIMM A DDR5 ONLY + DIMM B DDR5 ONLY)
6. Keyboard cable connector (KB)
7. Keyboard-backlight cable connector (BL)
8. Battery cable connector (BATT)
9. Touchpad cable connector (TP)
10. Fan cable connector (FAN)
11. Speaker cable connector (SPK)

12. M.2 solid-state drive slot (SSD)

The following images indicate the location of the system board and provide a visual representation of the removal procedure.

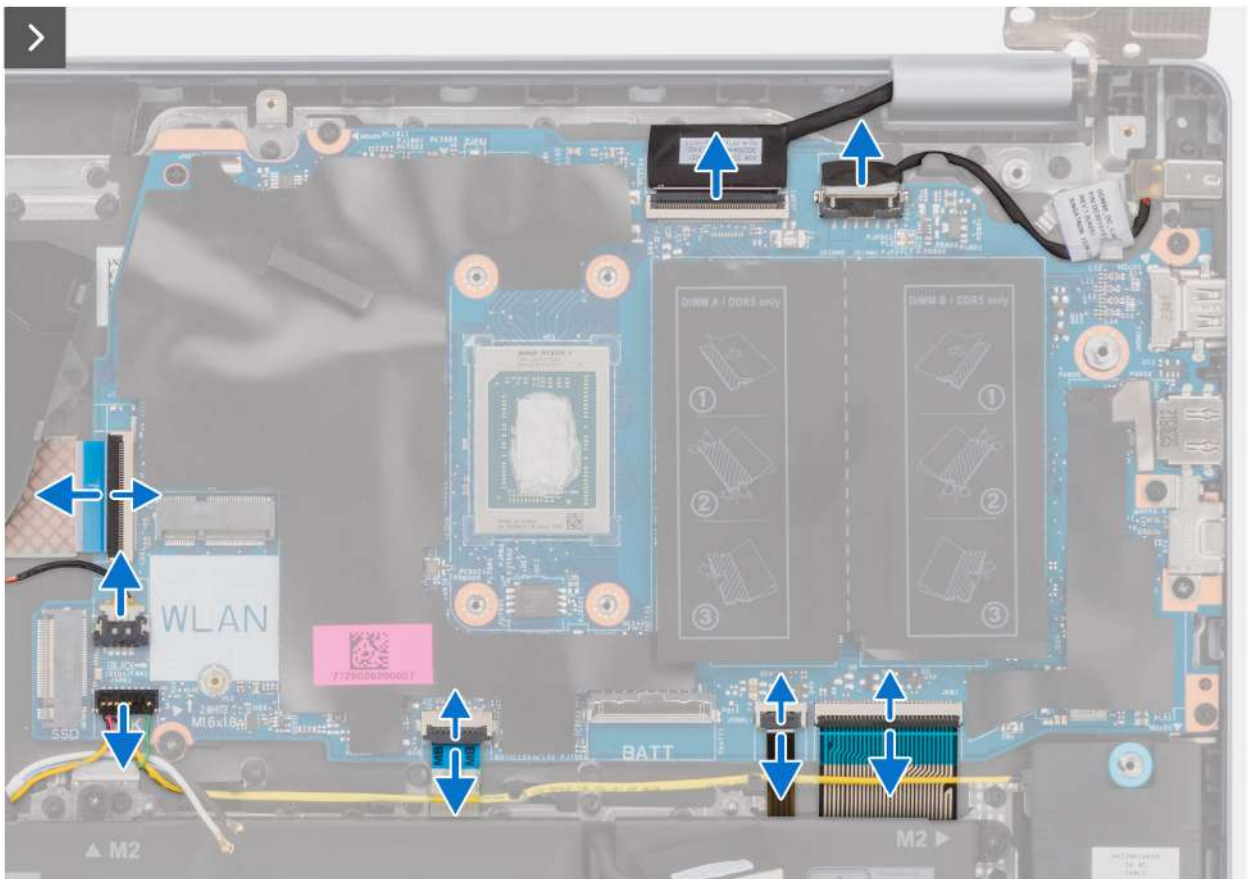
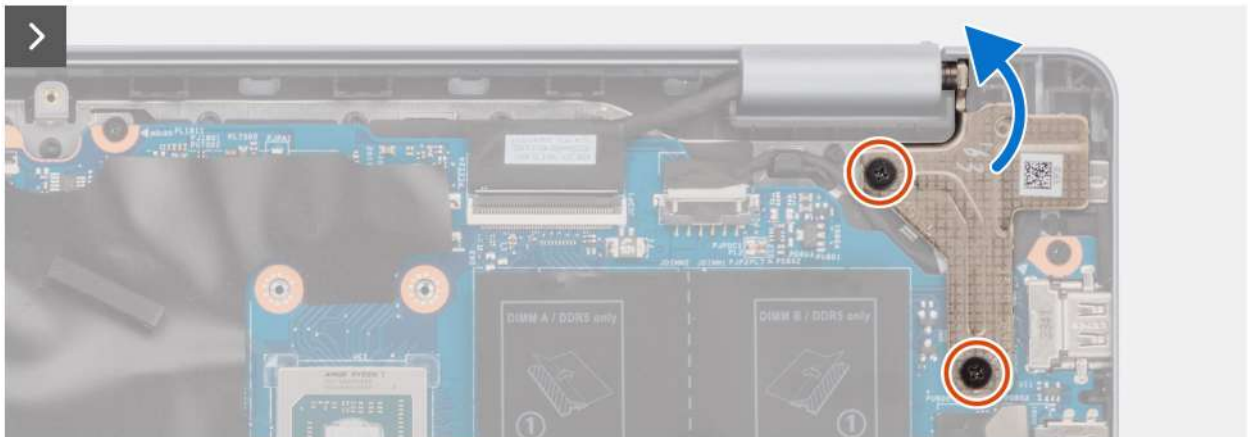



Figure 35. Removing the system board

Steps

1. Remove the two screws (M2.5x5) that secure the hinge to the palm-rest and keyboard assembly.
2. Open the display hinge at an angle of 90 degrees.
3. Disconnect the following cables on the system board:
 - a. eDP cable from its connector (eDP)
 - b. power-adapter port cable from its connector (DCIN)
 - c. keyboard cable from its connector (KB)
 - d. keyboard-backlight cable from its connector (BL)
 - e. touchpad cable from its connector (TP)
 - f. speaker cable from its connector (SPK)
 - g. fan cable from its connector (FAN)
 - h. I/O board cable from its connector (IO)
4. Remove the screw (M1.6x1.8) that secures the system board to the palm-rest and keyboard assembly.
5. Remove the four screws (M2x3.5) that secure the system board to the palm-rest and keyboard assembly.

i **NOTE:** A USB Type-C bracket is secured to the system board with a single screw (M2x3.5). The bracket is bundled with the system board as a service part and **MUST NOT** be removed from the system board.





6. Carefully lift and remove the system board from the palm-rest and keyboard assembly.

Installing the system board

CAUTION: The information in this section is intended for authorized service technicians only.

Prerequisites

If you are replacing a component, remove the existing component before performing the installation procedure.

About this task

NOTE: When installing the system board to replace/access other parts, the system board can be installed with the heat sink to it in order to simplify the procedure and preserve the thermal bond between the system board and heat sink.

The following image indicates the connectors on your system board.

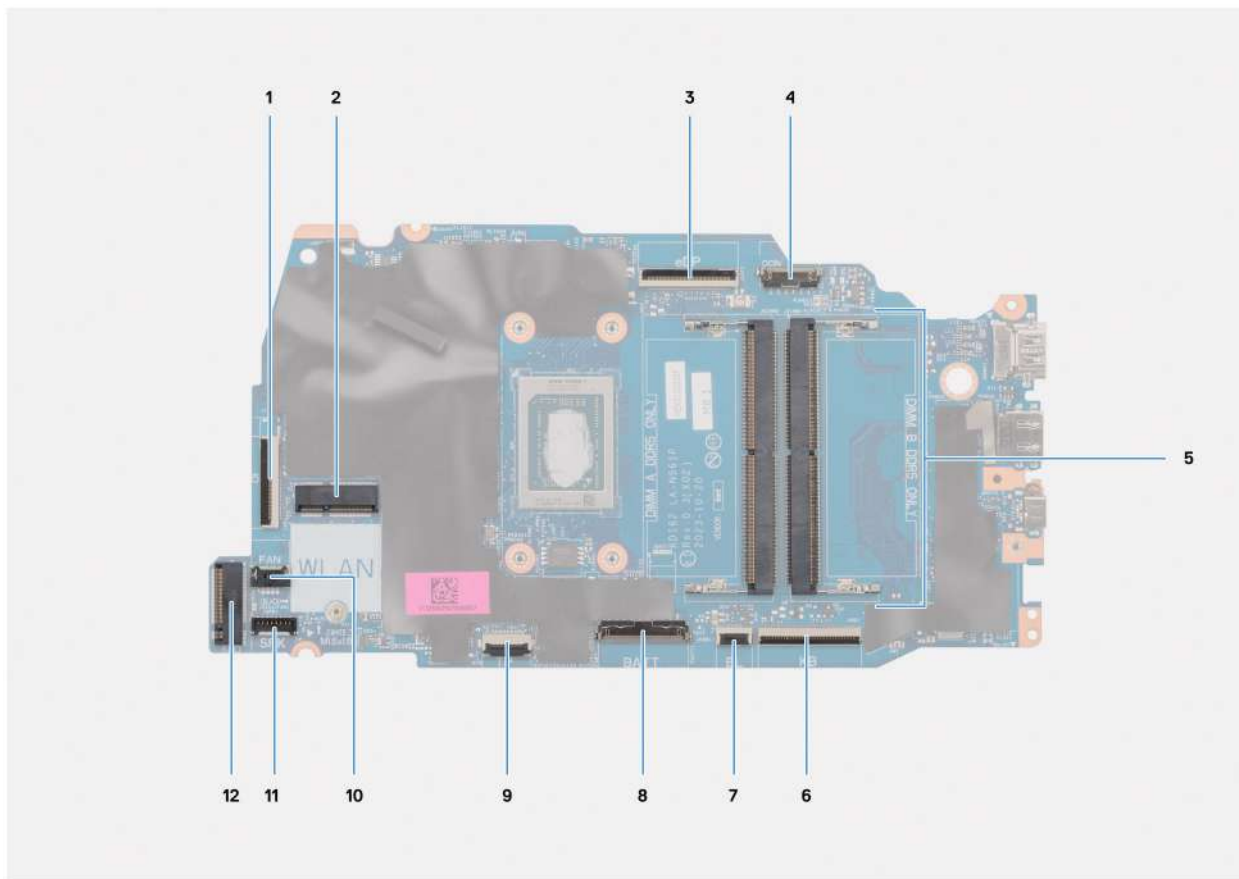
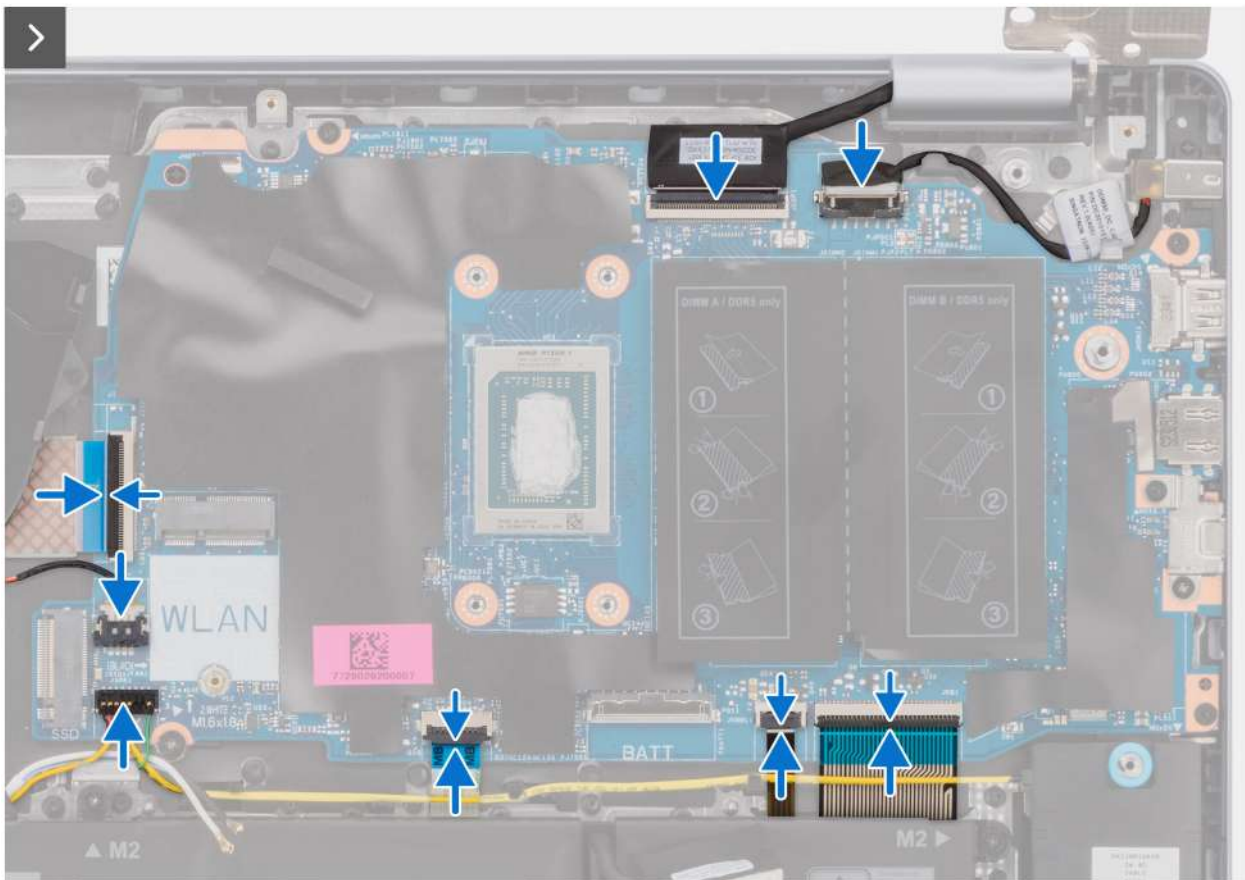
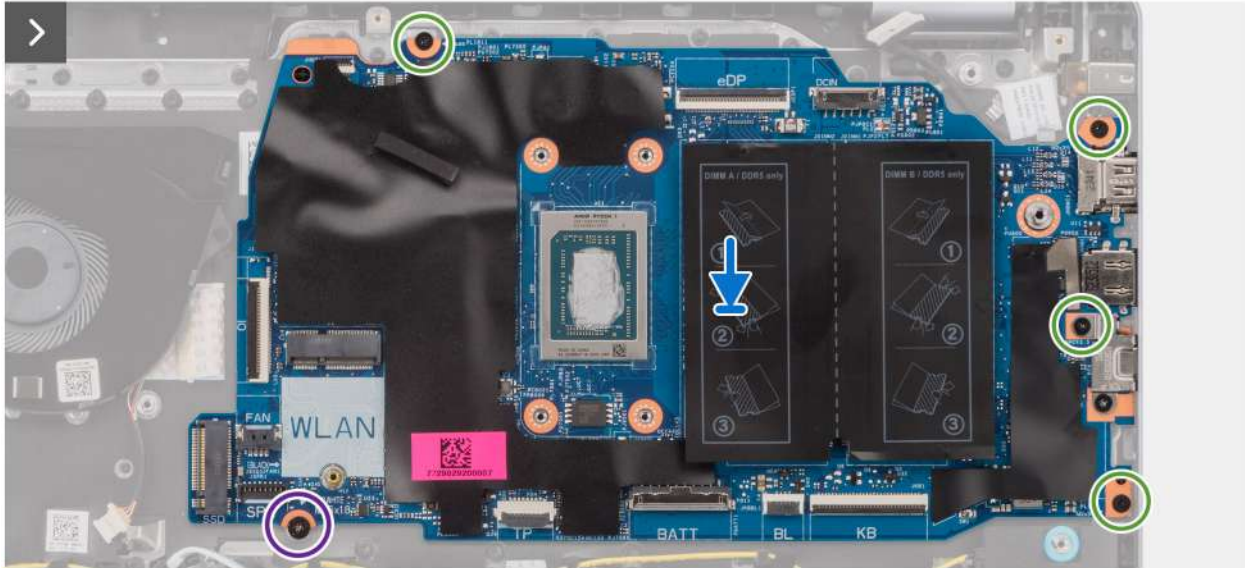

Figure 36. System board overview

1. I/O-board cable connector (IO)
2. Wireless card slot (WLAN)
3. Display cable connector (eDP)
4. Power-adaptor port cable connector (DCIN)
5. Memory slots x2 (DIMM A DDR5 ONLY + DIMM B DDR5 ONLY)
6. Keyboard cable connector (KB)
7. Keyboard-backlight cable connector (BL)
8. Battery cable connector (BATT)
9. Touchpad cable connector (TP)
10. Fan cable connector (FAN)
11. Speaker cable connector (SPK)
12. M.2 solid-state drive slot (SSD)

The following images indicate the location of the system board and provide a visual representation of the installation procedure.



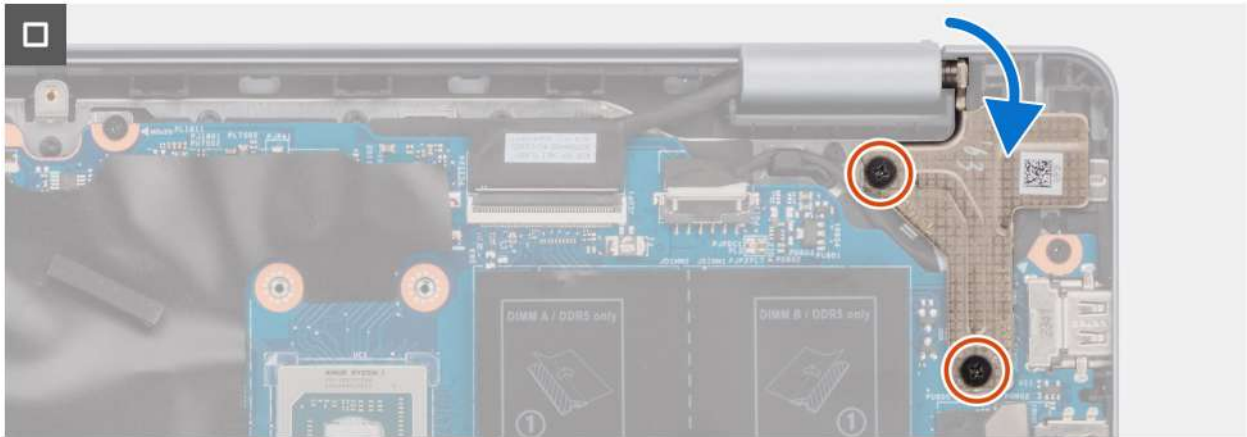

Figure 37. Installing the system board

Steps

1. Align the ports on the system board to the port openings on the palm-rest and keyboard assembly.
2. At an angle, carefully slide and place the system board on the palm-rest and keyboard assembly.
3. Align the screw holes on the system board with the screw holes on the palm-rest and keyboard assembly.
4. Replace the screw (M1.6x1.8) that secures the system board to the palm-rest and keyboard assembly.
5. Replace the four screws (M2x3.5) that secure the system board to the palm-rest and keyboard assembly.
 - NOTE:** A USB Type-C bracket is secured to the system board with a single screw (M2x3.5). The bracket is bundled with the system board as a service part and **MUST NOT** be removed from the system board.
6. Connect the following cables to the system board:
 - a. I/O board cable to its connector (IO)
 - b. fan cable to its connector (FAN)
 - c. speaker cable to its connector (SPK)
 - d. touchpad cable to its connector (TP)
 - e. keyboard-backlight cable to its connector (BL)
 - f. keyboard cable to its connector (KB)
 - g. power-adapter port cable to its connector (DCIN)
 - h. eDP cable to its connector (eDP)
7. Close the display hinge.
8. Replace the two screws (M2.5x5) that secure the hinge to the palm-rest and keyboard assembly.

Next steps

1. Install the [heat sink](#).
2. Install the [fan](#).
3. Install the [wireless card](#).
4. Install the [solid-state drive](#).
5. Install the [memory module](#).
6. Install the [base cover](#).
7. Follow the procedure in [After working inside your computer](#).

Palm-rest and keyboard assembly

Removing the palm-rest and keyboard assembly

CAUTION: The information in this section is intended for authorized service technicians only.

Prerequisites

1. Follow the procedure in [Before working inside your computer](#).
2. Remove the [base cover](#).
3. Remove the [memory module](#).
4. Remove the [solid-state drive](#).
5. Remove the [wireless card](#).
6. Remove the [speakers](#).
7. Remove the [fan](#).
8. Remove the [battery](#).
9. Remove the [heat sink](#).
10. Remove the [touchpad assembly](#).
11. Remove the [I/O-board cable](#).
12. Remove the [display assembly](#).
13. Remove the [I/O board](#).
14. Remove the [power button](#) or the [power button with optional fingerprint reader](#), whichever is applicable.
15. Remove the [power-adaptor port](#).
16. Remove the [system board](#).

NOTE: The system board can be removed with the heat sink attached to it in order to simplify the procedure and preserve the thermal bond between the system board and heat sink.

About this task

NOTE: The palm-rest and keyboard assembly cannot be further disassembled. If the keyboard is malfunctioning and is required to be replaced, replace the entire palm-rest and keyboard assembly.

The image below shows the palm-rest and keyboard assembly after the pre-requisite procedures have been performed.

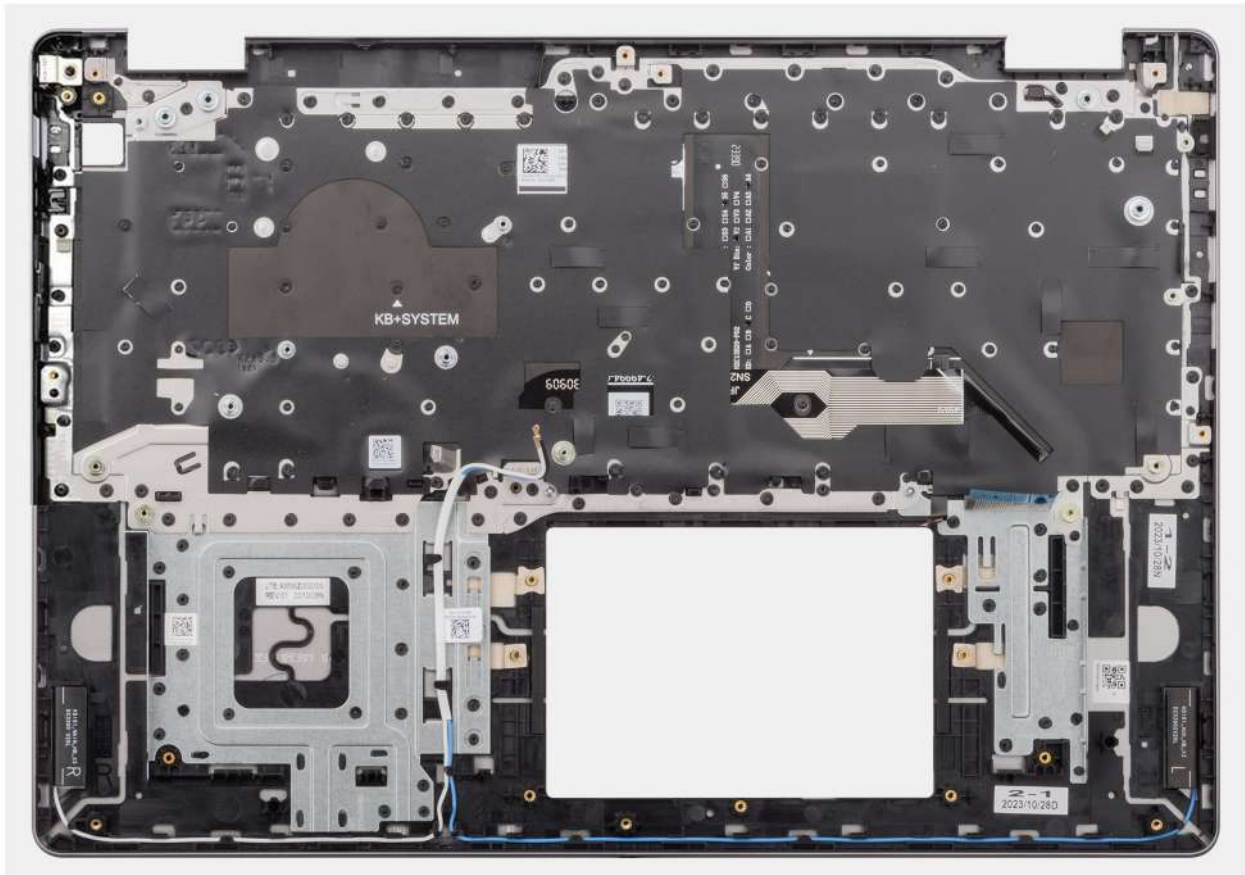

Figure 38. Removing the palm-rest and keyboard assembly

Steps

After performing the pre-requisites, you are left with the palm-rest and keyboard assembly.

Installing the palm-rest and keyboard assembly

CAUTION: The information in this section is intended for authorized service technicians only.

Prerequisites

If you are replacing a component, remove the existing component before performing the installation procedure.

About this task

NOTE: The system board can be installed with the heat sink attached to it in order to simplify the procedure and preserve the thermal bond between the system board and heat sink.

The following image indicates the location of the palm-rest and keyboard assembly and provides a visual representation of the installation procedure.

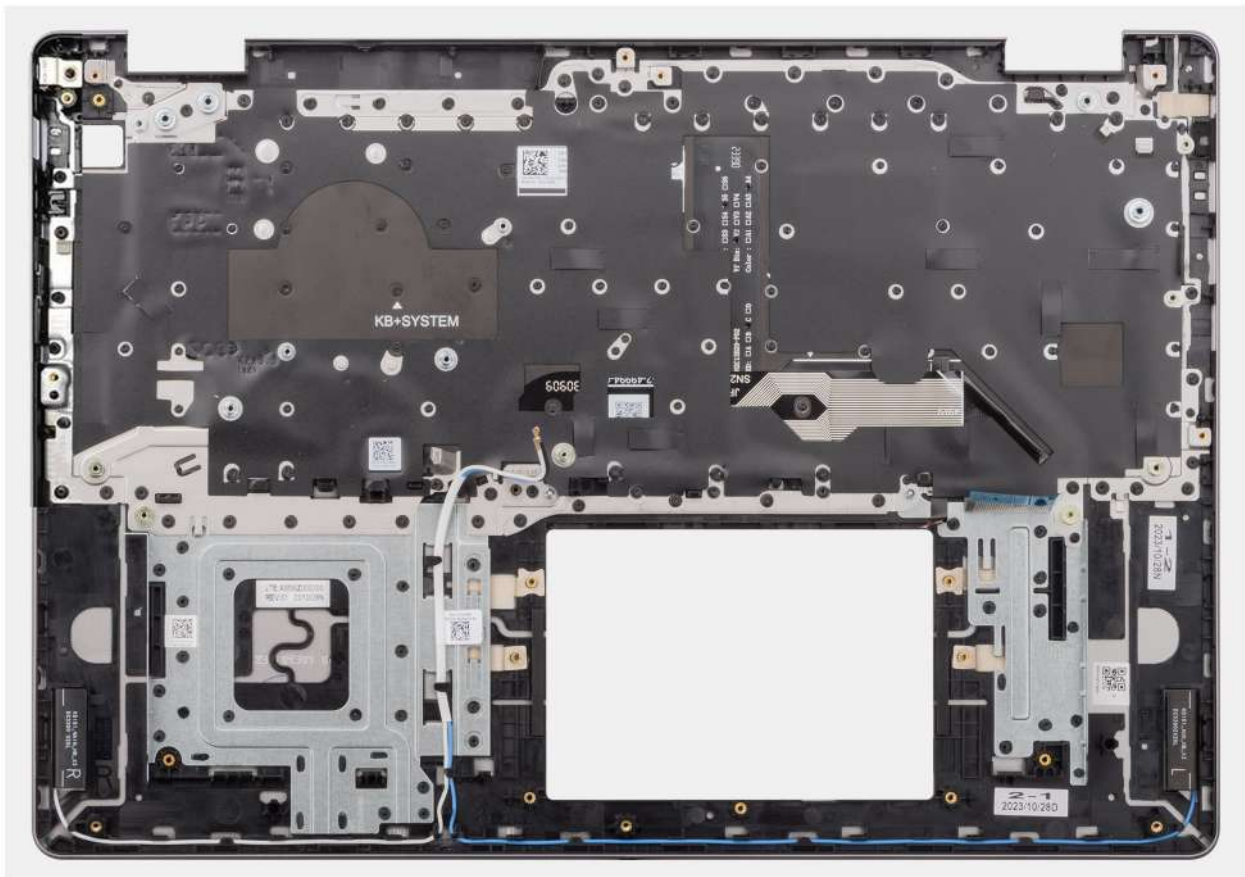

Figure 39. Installing the palm-rest and keyboard assembly

Steps

Place the palm-rest and keyboard assembly on a flat surface and perform the following steps to install the palm-rest and keyboard assembly.

Next steps

1. Install the [system board](#).
2. Install the [power-adaptor port](#).
3. Install the [power button](#) or the [power button with optional fingerprint reader](#), whichever is applicable.

4. Install the [I/O board](#).
5. Install the [display assembly](#).
6. Install the [I/O-board cable](#).
7. Install the [touchpad assembly](#).
8. Install the [heat sink](#).
9. Install the [battery](#).
10. Install the [fan](#).
11. Install the [speakers](#).
12. Install the [wireless card](#).
13. Install the [solid-state drive](#).
14. Install the [memory module](#).
15. Install the [base cover](#).
16. Follow the procedure in [After working inside your computer](#).

Software

This chapter details the supported operating systems along with instructions on how to install the drivers.

Operating system

Your Dell 16 DC16256 (M) supports the following operating systems:

For computers shipped with AMD Ryzen AI 5 330/Ryzen AI 7 350 processors:

- Windows 11 Home NextGen
- Windows 11 Pro NextGen

For computers shipped with AMD Ryzen 5 220/Ryzen 7 250 processors:

- Windows 11 Home
- Windows 11 Pro
- Windows 11 Education - National Education
- Ubuntu Linux 24.04.2 LTS

Drivers and downloads

When troubleshooting, downloading, or installing drivers, it is recommended that you read the [Dell Knowledge Base article Drivers and Downloads FAQs](#).

BIOS Setup

CAUTION: Certain changes can make your computer work incorrectly. Before you change the settings in BIOS Setup, it is recommended that you note down the original settings for future reference.

NOTE: Depending on the computer and the installed devices, the options that are listed in this section may differ.

Use BIOS Setup for the following purposes:

- Get information about the hardware installed in your computer, such as the amount of RAM and the capacity of the storage device.
- Change the system configuration information.
- Set or change user-selectable options such as the user password, enabling or disabling base devices, and configuring hard drive settings.

Entering BIOS Setup program

Turn on or restart your computer and press F2 immediately.

Navigation keys

NOTE: For most of the BIOS Setup options, changes that you make are recorded but do not take effect until you restart the computer.

Table 4. Navigation keys

Keys	Navigation
Up arrow	Moves to the previous field.
Down arrow	Moves to the next field.
Enter	Selects a value in the selected field (if applicable) or follows the link in the field.
Spacebar	Expands or collapses a drop-down list, if applicable.
Tab	Moves to the next focus area.
Esc	Moves to the previous page until you view the main screen. Pressing Esc in the main screen displays a message that prompts you to save any unsaved changes and restart the computer.

F12 One Time Boot menu

To enter the One Time Boot menu, turn on or restart your computer, and then press F12 immediately.

NOTE: If you are unable to enter the One Time Boot menu, repeat the above action.

The One Time Boot menu displays the devices that you can boot from and also display the options to start diagnostics. The boot menu options are:

- Removable Drive (if available)
- STXXXX Drive (if available)

NOTE: XXXX denotes the SATA drive number.

- Optical Drive (if available)
- SATA Hard Drive (if available)
- Diagnostics

The One Time Boot menu screen also displays the option to access BIOS Setup.

System setup options

NOTE: Depending on your computer and its installed devices, the items that are listed in this section may or may not appear.

Table 5. System setup options—Main menu

Main	
System Time	Displays the current time in hh:mm:ss format.
System Date	Displays the current date in mm/dd/yyyy format.
BIOS Version	Displays the BIOS version.
Product Name	Displays the model number of your computer.
Service Tag	Displays the service tag of your computer.
Asset Tag	Displays the asset tag of your computer.
CPU Type	Displays the processor type.
CPU Speed	Displays the processor speed.
CPU ID	Displays the processor identification code.
CPU Cache	
L1 Cache	Displays the processor L1 cache size.
L2 Cache	Displays the processor L2 cache size.
L3 Cache	Displays the processor L3 cache size.
M.2 PCIe SSD	Displays the PCIe SSD information connected to the M.2 slot.
AC Adapter Type	Displays the type of AC adapter.
System Memory	Displays the size of memory installed.
Memory Speed	Displays the speed of memory.
Keyboard Type	Displays the type of keyboard installed on the computer.

Table 6. System setup options—Advanced menu

Advanced	
USB Emulation	Enables or disables the USB emulation feature. This feature defines how the BIOS, in the absence of a USB-aware operating system, handles USB devices. USB emulation is always enabled during POST. NOTE: You cannot boot any type of USB device (floppy, hard drive, or memory key) when this option is off. Default: Enabled
SATA/NVMe Operation mode	Allows you to configure the operating mode of the integrated SATA hard drive controller. Default: AHCI /NVMe

Table 6. System setup options—Advanced menu (continued)

Advanced	
Adapter Warnings	Allows you to choose if the computer should display warning messages when you use AC adapters that are not supported by your computer. Default: Enabled
Function Key Behavior	Allows you to set function key or multimedia key as the default function key behavior. Default: Multimedia key
Keyboard Illumination	Selects the operating mode of the keyboard illumination feature. Default: Dim
Keyboard Backlight with AC	Selects the timeout value for the keyboard backlight when an AC adapter is plugged into the computer. Default: 1 minute
Keyboard Backlight with Battery	Selects the timeout value for the keyboard backlight when the computer is running on battery power. Default: 1 minute
Battery Health	Displays the battery health.
External USB Ports	Allows you to enable or disable the external USB ports. Default: Enabled
Enable Audio	Allows you to enable or disable the audio. Default: Enabled
Microphone	Allows you to enable or disable the microphone. Default: Enabled
Camera	Enables or disables the camera. Default: Enabled
Battery Charge Configuration	Set the battery charge settings with a preselected custom charge start and stop. Default: Adaptive
Advanced Battery Charge Configuration	Enable Advanced Battery Charge Configuration from the beginning of the day to a specified work period. Default: Disabled
IPv4 HTTP Support	Default: Disabled
IPv6 HTTP Support	Default: Disabled
Maintenance	
Data Wipe on next boot	Enables or disables data wipe on the next boot. Default: Disabled
BIOS Recovery from Hard Drive	Enables the user to recover from certain corrupted BIOS conditions from a recovery file on the user primary hard drive or an external USB key. Default: Enabled
BIOS Auto-Recovery	Enables BIOS to automatically recover BIOS without user actions.

Table 6. System setup options—Advanced menu (continued)

Advanced	
	Default: Disabled
SupportAssist System Resolution	
Auto OS Recovery Threshold	Controls the automatic boot flow for SupportAssist System Resolution Console and for the Dell OS Recovery tool. Default: 2
SupportAssist OS Recovery	Enables or disables the boot flow for the SupportAssist OS Recovery tool in the even of certain system errors. Default: Enabled

Table 7. System setup options—Security menu

Security	
Admin Password	Displays if the administrator password is clear or set. Default: Not Set
System Password	Displays if the system password is clear or set. Default: Not Set
Asset Tag	Allows you to set the asset tag.
Admin Password	Allows you to set the administrator password. The administrator password controls access to the system setup utility.
System Password	Allows you to set the system password. The system password controls access to the computer at boot.
Password Change	Allows you to permit or deny system password or HDD password changes. Default: Permitted
Absolute®	Allows you to track your computer Default: Enabled
Absolute® Status	Allows you to activate or deactivate the Absolute® feature Displays if the system password is clear or set. Default: Deactivate
WINDOWS SMM SECURITY MITIGATIONS TABLE (WSMT)	Enables or disables configuration of platform features on Dell Client Systems with WSMT-enabled BIOS. Default: Enabled
Firmware TPM	Enable or disable the firmware TPM. Default: Disabled
PPI Bypass for Clear Command	Allows you to control the TPM Physical Presence Interface (PPI). When enabled, this setting will allow the OS to skip BIOS PPI user prompts when issuing the Clear command. Changes to this setting take effect immediately. Default: Disabled
TPM Security	TPM 2.0 Security options.
TPM On	Enable or disable the TPM Security options. Default: On

Table 7. System setup options—Security menu (continued)

Security	
PPI Bypass for Enable Commands	<p>Controls the TPM Physical Presence Interface(PPI). When enabled, this setting allows the OS to skip BIOS PPI user prompts when issuing TPM PPI enable and activate commands.</p> <p>Default: Disabled</p>
PPI Bypass for Disable Commands	<p>Controls the TPM Physical Presence Interface(PPI). When enabled, this setting will allow the OS to skip BIOS PPI user prompts when issuing TPM PPI disable and deactivate commands(#2, 4, 7, 9, & 11).</p> <p>Default: Disabled</p>
Attestation Enable	<p>Allws the user to control whether the TPM Endorsement Hierarchy is available to the OS.</p> <p>Default: Enabled</p>
Key Storage Enable	<p>Allows the user to control whether TPM Storage Hierarchy is available to the operating system.</p> <p>Default: Enabled</p>
SHA-256	<p>Enables the BIOS and the TPM to use the SHA-256 hash algorithm to extend measurements into the TPM PCRs during BIOS boot.</p> <p>Default: Enabled</p>
Clear	<p>Clears the TPM owner information, and returns the TPM to the default state.</p> <p>Default: Disabled</p>
PPI Bypass for Clear Commands	<p>Controls the TPM Physical Presence Interface(PPI). When enabled, this setting will allow the OS to skip BIOS PPI user prompts when issuing the Clear command.</p> <p>Default: Disabled</p>
TPM State	<p>Displays the state of the TPM Module on the computer.</p> <p>Default: Enabled</p>
Enable Pre-Boot DMA support	<p>Enable or disable the pre-boot DMA support.</p> <p>Default: Enabled</p>
Enable OS kernel DMA support	<p>Enable or disable the OS kernel DMA support.</p> <p>Default: Enabled</p>
Internal Port DMA Compatibility Mode	<p>Enable or disable the boot compatibility for integrated PCIe peripherals by disabling PCIe DMA protection on internal PCIe ports.</p> <p>Default: Disable</p>
Secure Boot	
System Status:	
Secure Boot Database	<p>A security standard that ensures the device boots using only software that is trusted by the Original Equipment Manufacturer (OEM)</p> <p>Default: Installed and Locked</p>
Secure Boot Status	<p>Ensure that only trusted software can be executed on the system.</p>

Table 7. System setup options—Security menu (continued)

Security	
Secure Boot Mode	<p>Default: Disabled</p> <p>Prevents any malicious software from loading when computer starts up.</p>
User Customized Security	<p>Default: Deployed Mode</p>
Secure Boot	<p>Enables or disables Secure Boot.</p> <p>Default: Disabled</p>
Select Secure Mode	<p>Default: Deployed Mode</p>
Expert Key Management	
Custom Mode	<p>Allows you to manipulate the security key databases only if the system is in Custom Mode.</p> <p>Default: Disabled</p> <p>The options are:</p> <ul style="list-style-type: none"> ● PK (default) ● KEK ● db ● dbx <p>If you enable the Custom Mode , the relevant options for PK, KEK, db, and dbx appear.</p> <p>The options are:</p> <ul style="list-style-type: none"> ● Save to File- Saves the key to a user-selected file ● Replace from File- Replaces the current key with a key from a user-selected file ● Append from File- Adds a key to the current database from a user-selected file ● Delete- Deletes the selected key ● Reset All Keys- Resets to default setting ● Delete All Keys- Deletes all the keys
Enable Microsoft UEFI CA	<p>Enables UEFI CA to be included in the BIOS UEFI Secure Boot DB.</p> <p>Default: Disabled</p>

Table 8. System setup options—Boot menu

Boot	
File Browser Add Boot Option	Allows you to add or remove boot options.
UEFI Boot	Displays the location where UEFI bootable file is located.

Table 9. System setup options—Exit menu

Exit	
Exit Saving Changes	Allows you to exit system setup and save your changes.
Save Change Without Exit	Allows you to save your changes without exiting the BIOS setup.
Exit Discarding Changes	Allows you to exit the BIOS setup without saving the changes.

Table 9. System setup options—Exit menu (continued)

Exit	
Load Optimal Defaults	Allows you to restore default values for all system setup options.
Discard Changes	Allows you to load previous values for all system setup options.

Updating the BIOS

Updating the BIOS in Windows

About this task

CAUTION: If BitLocker is not suspended before updating the BIOS, the BitLocker key is not recognized the next time you reboot the computer. You will then be prompted to enter the recovery key to proceed, and the computer displays a prompt for the recovery key on each reboot. Failure to provide the recovery key can result in data loss or an operating system reinstall. For more information, see the Knowledge Base Resource [Updating the BIOS on Dell systems with BitLocker enabled](#).

CAUTION: Do not turn off the computer during the BIOS flash update process. The computer may not boot if you turn off your computer.

Steps

1. Go to [Dell Support Site](#).
2. Go to **Identify your product or ask support**. In the box, enter the product identifier, model, service request or describe what you are looking for, and then click **Search**.

NOTE: If you do not have the Service Tag, click **Detect This PC**. The site automatically detects your device, and you can then click **Explore Product Support** to go to the support page for your device. You can also use the product ID or manually browse for your computer model.

3. Click **Drivers & Downloads**.
4. Select the operating system installed on your computer.
5. In the **Category** drop-down list, select **BIOS**.
6. Select the latest version of BIOS, and click **Download** to download the BIOS file for your computer.
7. After the download is complete, navigate to the folder where the BIOS update file has been saved.
8. Double-click the BIOS update file and follow the on-screen instructions.

For more information, search in the Knowledge Base Resource at [Dell Support Site](#).

Updating the BIOS using the USB drive in Windows

About this task

CAUTION: If BitLocker is not suspended before updating the BIOS, the BitLocker key is not recognized the next time you reboot the computer. You will then be prompted to enter the recovery key to proceed, and the computer displays a prompt for the recovery key on each reboot. Failure to provide the recovery key can result in data loss or an operating system reinstall. For more information, see the Knowledge Base Resource [Updating the BIOS on Dell systems with BitLocker enabled](#).

CAUTION: Do not turn off the computer during the BIOS flash update process. The computer may not boot if you turn off your computer.

Steps

1. Go to [Dell Support Site](#).
2. Go to **Identify your product or ask support**. In the box, enter the product identifier, model, service request or describe what you are looking for, and then click **Search**.
 **NOTE:** If you do not have the Service Tag, click **Detect This PC**. The site automatically detects your device, and you can then click **Explore Product Support** to go to the support page for your device. You can also use the product ID or manually browse for your computer model.
3. Click **Drivers & Downloads**.
4. Select the operating system installed on your computer.
5. In the **Category** drop-down list, select **BIOS**.
6. Select the latest version of BIOS, and click **Download** to download the BIOS file for your computer.
7. Create a bootable USB drive. For more information, search the Knowledge Base Resource at [Dell Support Site](#).
8. Copy the BIOS Setup program file to the bootable USB drive.
9. Connect the bootable USB drive to the computer that needs the BIOS update.
10. Restart the computer and press **F12**.
11. Select the USB drive from the **One Time Boot Menu**.
12. Type the BIOS Setup program filename and press **Enter**.
The **BIOS Update Utility** appears.
13. Follow the on-screen instructions to complete the BIOS update.

Updating the BIOS from the One-Time boot menu

To update the BIOS from the One-Time boot menu, see Knowledge base article [000128928](#) at [Dell Support Site](#).

System and setup password

 **CAUTION:** The password features provide a basic level of security for the data on your computer.

 **CAUTION:** Ensure that your computer is locked when it is not in use. Anyone can access the data that is stored on your computer, when left unattended.

Table 10. System and setup password

Password type	Description
System password	Password that you must enter to boot to your operating system.
Setup password	Password that you must enter to access and change the BIOS settings of your computer.

You can create a system password and a setup password to secure your computer.

 **NOTE:** The System and setup password feature is disabled by default.

Assigning a System Setup password

Prerequisites

You can assign a new System or Admin Password only when the status is set to **Not Set**. To enter BIOS System Setup, press F2 immediately after a power-on or reboot.

Steps

1. To enter the **System Setup**, press **F2** immediately after a power-on or reboot.

2. In the **System BIOS** or **System Setup** screen, select **Security** and press Enter.
The **Security** screen is displayed.
3. Select **System/Admin Password** and create a password in the **Enter the new password** field.
Use the following guidelines to create the system password:
 - Password can be up to 32 characters.
 - Password must contain at least one special character: "(! " # \$ % & ' * + , - . / : ; < = > ? @ [\] ^ _ ` { | })")"
 - The password can contain numbers from 0 to 9.
 - The password can contain alphabets A to Z and a to z.
4. Type the system password that you entered earlier in the **Confirm new password** field and click **OK**.
5. Press Y to save the changes.
The computer restarts.

Deleting or changing an existing system password or setup password

Prerequisites

Ensure that the **Password Status** is Unlocked in the System Setup before attempting to delete or change the existing system password and/or setup password. You cannot delete or change an existing system password or setup password if the **Password Status** is Locked. To enter the System Setup, press F2 immediately after a power-on or reboot.

Steps

1. To enter the **System Setup**, press **F2** immediately after a power-on or reboot.
2. In the **System BIOS** or **System Setup** screen, select **System Security** and press Enter.
The **System Security** screen is displayed.
3. In the **System Security** screen, verify that the **Password Status** is Unlocked.
4. Select **System Password**. Update or delete the existing system password, and press Enter or Tab.
5. Select **Setup Password**. Update or delete the existing setup password, and press Enter or Tab.
 **NOTE:** If you change the system password and/or setup password, reenter the new password when prompted. If you delete the system password and/or setup password, confirm the deletion when prompted.
6. Press Esc. A message prompts you to save the changes.
7. Press Y to save the changes and exit from **System Setup**.
The computer restarts.

Clearing system and setup passwords

About this task

To clear the system or setup passwords, contact Dell technical support as described at [Contact Support](#).

-  **NOTE:** For information about how to reset Windows or application passwords, see the documentation accompanying Windows or your application.

Troubleshooting

Handling swollen rechargeable Li-ion batteries

Like most laptops, Dell laptops use Lithium-ion batteries. One type of Lithium-ion battery is the rechargeable Li-ion battery. Rechargeable Li-ion batteries have increased in popularity in recent years and have become a standard in the electronics industry due to customer preferences for a slim form factor (especially with newer ultra-thin laptops) and long battery life. Inherent to rechargeable Li-ion battery technology is the potential for swelling of the battery cells.

A swollen battery may impact the performance of the laptop. To prevent possible further damage to the device enclosure or internal components leading to malfunction, discontinue the use of the laptop and discharge it by disconnecting the AC adapter and letting the battery drain.

Swollen batteries should not be used and must be replaced and disposed of properly. We recommend contacting Dell Support for options to replace a swollen battery under the terms of the applicable warranty or service contract, including options for replacement by a Dell authorized service technician.

The guidelines for handling and replacing rechargeable Li-ion batteries are as follows:

- Exercise caution when handling rechargeable Li-ion batteries.
- Discharge the battery before removing it from the laptop. To discharge the battery, unplug the AC adapter from the computer and operate the computer only on battery power. The battery is fully discharged when the computer no longer turns on when the power button is pressed.
- Do not crush, drop, mutilate, or penetrate the battery with foreign objects.
- Do not expose the battery to high temperatures, or disassemble battery packs and cells.
- Do not apply pressure to the surface of the battery.
- Do not bend the battery.
- Do not use tools of any type to pry on or against the battery.
- If a battery gets stuck in a device as a result of swelling, do not try to free it as puncturing, bending, or crushing a battery can be dangerous.
- Do not attempt to reassemble a damaged or swollen battery into a laptop.
- Swollen batteries that are covered under warranty should be returned to Dell in an approved shipping container (provided by Dell)—this is to comply with transportation regulations. Swollen batteries that are not covered under warranty should be disposed of at an approved recycling center. Contact Dell Support at [Dell Support Site](#) for assistance and further instructions.
- Using a non-Dell or incompatible battery may increase the risk of fire or explosion. Replace the battery only with a compatible battery purchased from Dell that is designed to work with your Dell computer. Do not use a battery from other computers with your computer. Always purchase genuine batteries from [Dell Site](#) or otherwise directly from Dell.

Rechargeable Li-ion batteries can swell for various reasons such as age, number of charge cycles, or exposure to high heat. For more information about how to improve the performance and lifespan of the laptop battery and to minimize the possibility of occurrence of the issue, search Dell laptop battery at [Dell Support Site](#).

Dell SupportAssist Pre-boot System Performance Check diagnostics

About this task

SupportAssist diagnostics (also known as system diagnostics) performs a complete check of your hardware. The Dell SupportAssist Pre-boot System Performance Check diagnostics is embedded within the BIOS and launched by the BIOS internally. The embedded system diagnostics provides options for particular devices or device groups allowing you to:

- Run tests automatically or in an interactive mode.
- Repeat the tests.
- Display or save test results.
- Run thorough tests to add more options and obtain details about any failed devices.

- View status messages that inform you when the tests are completed successfully.
- View error messages that inform you of problems encountered during testing.

NOTE: Some tests for specific devices require user interaction. Always ensure that you are present at the computer when the diagnostic tests are performed.

For more information, see [How to Run Dell Preboot Diagnostics and Hardware Tests on Your Dell Computer](#).

Running the SupportAssist Pre-Boot System Performance Check

Steps

1. Turn on your computer.
2. As the computer boots, press the F12 key.
3. On the boot menu screen, select **Diagnostics**.
The diagnostic quick test begins.
NOTE: For more information about running the SupportAssist Pre-Boot System Performance Check on a specific device, see [Dell Support Site](#).
4. If there are any issues, error codes are displayed.
Note the error code and validation number and contact Dell.

Built-in self-test (BIST)

Motherboard Built-In Self-Test (M-BIST)

M-BIST is the system board onboard self-test diagnostics tool that improves the diagnostics accuracy of system board Embedded Controller (EC) failures.

NOTE: M-BIST can be manually initiated before Power On Self-Test (POST).

How to run M-BIST

NOTE: Before initiating M-BIST, ensure that the computer is in a power-off state.

1. Press and hold both the **M** key and the power button to initiate M-BIST.
2. The battery-status light may exhibit two states:
 - Off: No fault was detected.
 - Amber and White: Indicates a problem with the system board.
3. If there is a failure with the system board, the battery-status light flashes one of the following error codes for 30 seconds:

Table 11. LED error codes

Blinking Pattern		Possible Problem
Amber	White	
2	1	CPU Failure
2	8	LCD Power Rail Failure
1	1	TPM Detection Failure
2	4	Memory/RAM failure

4. If there is no failure with the system board, the LCD cycles through the solid color screens (that are described in the LCD-BIST) for 30 seconds and then turn off.

Logic Built-in Self-test (L-BIST)

L-BIST is an enhancement to the single LED error code diagnostics and is automatically initiated during POST. L-BIST will check the LCD power rail. If there is no power being supplied to the LCD (that is if the L-BIST circuit fails), the battery status LED flashes either an error code [2,8] or an error code [2,7].

NOTE: If L-BIST fails, LCD-BIST cannot function as no power will be supplied to the LCD.

How to invoke the L-BIST

1. Turn on your computer.
2. If the computer does not start up normally, look at the battery status LED:
 - If the battery status LED flashes an error code [2,7], the display cable may not be connected properly.
 - If the battery status LED flashes an error code [2,8], there is a failure on the LCD power rail of the system board, hence there is no power that is supplied to the LCD.
3. For cases, when a [2,7] error code is shown, check to see if the display cable is properly connected.
4. For cases when a [2,8] error code is shown, replace the system board.

LCD Built-in Self-Test (LCD-BIST)

Dell laptops have a built-in diagnostic tool that helps you determine if the screen abnormality you are experiencing is an inherent problem with the LCD (screen) of the Dell laptop or with the video card (GPU) and computer settings.

When you notice screen abnormalities like flickering, distortion, clarity issues, fuzzy or blurry image, horizontal or vertical lines, color fade, it is always a good practice to isolate the LCD (screen) by running the LCD-BIST.

How to invoke the LCD-BIST

1. Turn off your computer.
2. Disconnect any peripherals that are connected to the computer. Connect only the AC adapter (charger) to the computer.
3. Ensure that the LCD (screen) is clean (no dust particles on the surface of the screen).
4. Press and hold the **D** key and press the power button to enter LCD-BIST mode. Continue to hold the **D** key until the computer boots up.
5. The screen displays solid colors and changes colors on the entire screen to white, black, red, green, and blue twice.
6. Then it displays the colors white, black, and red.
7. Carefully inspect the screen for abnormalities (any lines, fuzzy color, or distortion on the screen).
8. At the end of the last solid color (red), the computer shuts down.

NOTE: Dell SupportAssist Preboot diagnostics upon launch initiates an LCD-BIST first, expecting a user intervention to confirm functionality of the LCD.

System-diagnostic lights

This section lists the system-diagnostic lights of your Dell 16 DC16256 (M).

Table 12. System-diagnostic lights

Blinking pattern		Problem description
Amber	White	
1	1	TPM detection failure
1	2	Unrecoverable SPI Flash Failure
1	3	Short in hinge cable tripped OCP1
1	4	Short in hinge cable tripped OCP2
1	5	EC unable to program i-Fuse

Table 12. System-diagnostic lights (continued)

Blinking pattern		Problem description
Amber	White	
1	6	Generic catch-all for ungraceful EC code flow errors
1	7	Non-RPMC Flash on Boot Guard fused system
1	8	Chipset "Catastrophic Error" signal has tripped
2	1	CPU failure
2	2	System board failure (included BIOS corruption or ROM error)
2	3	No memory or RAM detected
2	4	Memory or RAM failure
2	5	Invalid memory installed
2	6	System board or Chipset Error
2	7	LCD failure (SBIOS message)
2	8	LCD failure (EC detection of power rail failure)
3	2	PCI or Video card or chip failure
3	3	BIOS Recovery image not found
3	4	BIOS Recovery image found but invalid
3	5	Power rail failure
3	6	Flash corruption is detected by SBIOS.
3	7	Timeout waiting on ME to reply to HECI message.

NOTE: Blinking 3-3-3 LEDs on Lock LED (Caps-Lock or Num Lock), Power button LED (without Fingerprint reader), and Diagnostic LED indicates failure to provide input during LCD panel test on Dell SupportAssist Preboot System Performance. Check diagnostics.

Recovering the operating system

When your computer is unable to boot to the operating system even after repeated attempts, it automatically starts Dell SupportAssist OS Recovery.

Dell SupportAssist OS Recovery is a stand-alone tool that is preinstalled on Dell computers running the Windows operating system. It consists of tools to diagnose and troubleshoot issues that may occur before your computer boots to the operating system. It enables you to diagnose hardware issues, repair your computer, back up your files, and restore your computer to its factory state.

You can also download it from the Dell Support website to troubleshoot and fix your computer when it fails to boot into the primary operating system due to software or hardware failures.

For more information about the Dell SupportAssist OS Recovery, see *Dell SupportAssist OS Recovery User's Guide at Serviceability Tools at the Dell Support Site*. Click **SupportAssist** and then click **SupportAssist OS Recovery**.

NOTE: Windows 11 IoT Enterprise LTSC 2024 and Dell ThinOS 10 do not support Dell SupportAssist. For more information about recovering ThinOS 10, see [Recovery mode using R-Key](#).

Real-Time Clock (RTC Reset)

The Real-Time Clock (RTC) reset function enables you or the service technician to recover Dell computers from No POST/No Power/No Boot situations.

Start the RTC reset with the computer powered off and connected to AC power. Press and hold the power button for thirty seconds. The computer RTC Reset occurs after you release the power button.

Backup media and recovery options

It is recommended to create a recovery drive to troubleshoot and fix problems that may occur with Windows. Dell provides multiple options for recovering the Windows operating system on your Dell computer. For more information, see [Dell Windows Backup Media and Recovery Options](#).

Network power cycle

About this task

If your computer is unable to access the Internet due to network connectivity issues, reset your network devices by performing the following steps:

Steps

1. Turn off the computer.
2. Turn off the modem.
 **NOTE:** Some Internet service providers (ISPs) provide a modem and router combo device.
3. Turn off the wireless router.
4. Wait for 30 seconds.
5. Turn on the wireless router.
6. Turn on the modem.
7. Turn on the computer.

Drain flea power (perform hard reset)

About this task

Flea power is the residual static electricity that remains in the computer even after it has been powered off and the battery is removed.

For your safety, and to protect the sensitive electronic components in your computer, you must drain residual flea power before removing or replacing any components in your computer.

Draining flea power, also known as performing a "hard reset," is also a common troubleshooting step if your computer does not turn on or boot into the operating system.

Perform the following steps to drain the flea power:

Steps

1. Turn off the computer.
2. Disconnect the power adapter from the computer.
3. Remove the base cover.
4. Remove the battery.
 **CAUTION: The battery is a Field Replaceable Unit (FRU) and the removal and installation procedures are intended for authorized service technicians only.**
5. Press and hold the power button for 20 seconds to drain the flea power.

6. Install the battery.
7. Install the base cover.
8. Connect the power adapter to the computer.
9. Turn on the computer.

 **NOTE:** For more information about performing a hard reset, go to [Dell Support Site](#). On the menu bar at the top of the Support page, select Support > Support Library. In the Search field on the Support Library page, type the keyword, topic, or model number, and then click or tap the search icon to view the related articles.

Getting help and contacting Dell

Self-help resources

You can get information and help on Dell products and services using these self-help resources:

Table 13. Self-help resources

Self-help resources	Resource location
Information about Dell products and services	Dell Site
Contact Support	In Windows search, type <code>Contact Support</code> , and press Enter.
Online help for operating system	Windows Support Site Linux Support Site
Access top solutions, diagnostics, drivers and downloads, and learn more about your computer through videos, manuals, and documents.	Your Dell computer is uniquely identified using a Service Tag or Express Service Code. To view relevant support resources for your Dell computer, enter the Service Tag or Express Service Code at Dell Support Site . For more information about how to find the Service Tag for your computer, see Locate the Service Tag on your computer .
Dell knowledge base articles	<ol style="list-style-type: none"> 1. Go to Dell Support Site. 2. On the menu bar at the top of the Support page, select Support > Support Library. 3. In the Search field on the Support Library page, type the keyword, topic, or model number, and then click or tap the search icon to view the related articles.

Contacting Dell

To contact Dell for sales, technical support, or customer service issues, see [Contact Support at Dell Support Site](#).

 **NOTE:** Availability of the services may vary depending on the country or region, and product.

 **NOTE:** If you do not have an active Internet connection, you can find contact information in your purchase invoice, packing slip, bill, or Dell product catalog.

Revision history

Tracks all updates that are made to the document. It typically includes the date of change, version number, and a brief description of the modification. This log helps maintain transparency, accountability, and a clear timeline of progress.

Table 14. Revision history

Revision	Date	Description
A01	March 2026	Added Quebec requirement information.
A00	August 2025	Original publish date.