

ASSEMBLY INSTRUCTIONS

# Nightstand

MOD-7236 / V0.04.22.25

---

**modway**



Questions? Contact us!

609.256.9000

[cs@modway.com](mailto:cs@modway.com)

# Welcome.

## Let's get started.

Before you begin, here are some things to keep in mind:

Assembly will take most people **about 60 minutes**. Consider having a friend help you!

**Only use hand tools to assemble this item**  
Do not use power tools. Do not tighten bolts or screws completely until all hardware is lined up and inserted into the holes.

**Read through all of the instructions before starting. Make sure you have all parts and components before discarding any packing materials.**

Do not over-tighten screws and bolts to avoid stripping the hardware or cracking the item.

Assemble your item on a flat, carpeted area, with plenty of space to work. This will prevent damage and scratches to your floors or the item while you're assembling the product.

Keep all components and packaging out of reach of children or animals to avoid risk of choking or suffocation.







**Care instructions are listed in the last step of this manual.**

**WAIT!**

**Missing parts or hardware? Need assistance?**  
Contact us before returning your item.  
We're here to help!

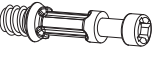
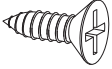
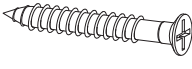
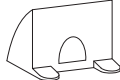
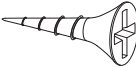
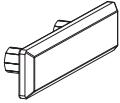

## HARDWARE INCLUDED IN THE BOX:

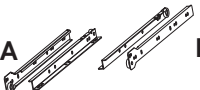
A		Cam Bolt Ø6 x 35 mm	x8
B		Cam Lock Ø15 mm	x8
C		Cam Lock Ø12 mm	x8
D		Wood Dowel Ø8 x 30 mm	x8
E		Wood Dowel Ø6 x 30 mm	x4
F		Cam Bolt Ø6 x 32 mm	x8
G		Screw M 3.5 x 13 mm	x12
H		Screw M 4 x 39 mm	x8
I		Wedge	x14
J		Screw M 3.5 x 15.5 mm	x14
K		Floor Glide	x4
L		Screw M 6 x 10.5 mm	x8
RM35A		Drawer Runner	x2

## WHAT YOU NEED:



Phillips



Phillips Head Screwdriver

# FURNITURE COMPONENTS INCLUDED IN THE BOX:

All parts are numbered with a sticker according to this list.

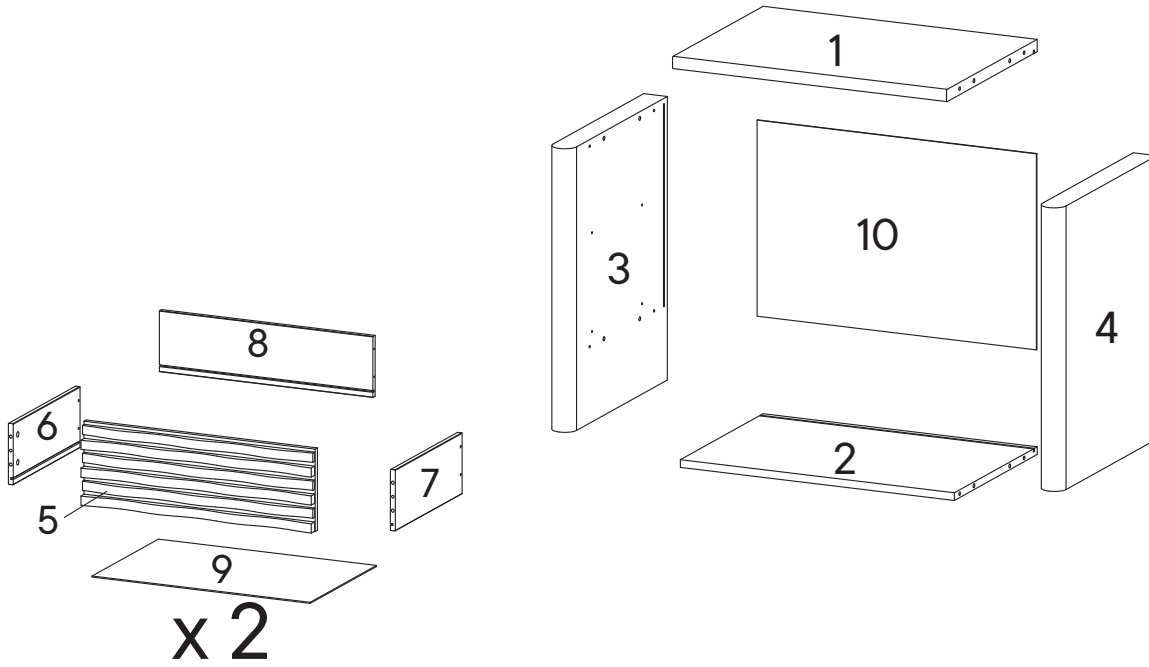

1	Top Board	x1	6	Side Drawer Left	x2
2	Bottom Board	x1	7	Side Drawer Right	x2
3	Side Board Left	x1	8	Back Drawer	x2
4	Side Board Right	x1	9	Bottom Drawer	x2
5	Front Drawer	x2	10	Back Board	x1

HARDWARE

- E** Wood Dowel Ø6 x 30 mm x4
- F** Cam Bolt Ø6 x 32 mm x8

COMPONENTS

- 5** Front Drawer x2
- 6** Side Drawer Left x2
- 7** Side Drawer Right x2

1.1 Insert Cam Bolt Ø6 x 32 mm (F) into the Front Drawer (5), then tighten using screwdriver.

1.2 Insert Wood Dowel Ø6 x 30 mm (E) into the Side Drawer Left (6).

1.3 Insert Wood Dowel Ø6 x 30 mm (E) into the Side Drawer Right (7).

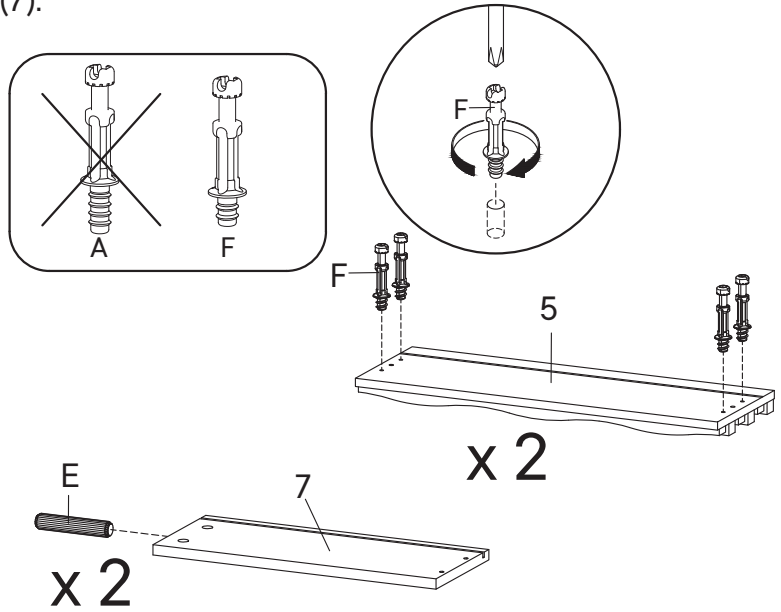

STEP 02

HARDWARE

- C** Cam Lock Ø12 mm x8

COMPONENTS

- 5** Front Drawer x2
- 6** Side Drawer Left x2
- 7** Side Drawer Right x2
- 9** Bottom Drawer x2

2.1 Combine Side Drawers (6&7) into Front Drawer (5) secure with Cam Lock Ø12 mm (C) then tighten using screwdriver.

2.2 Insert Bottom Drawer (9), into Front Drawer with laminated face facing upward.

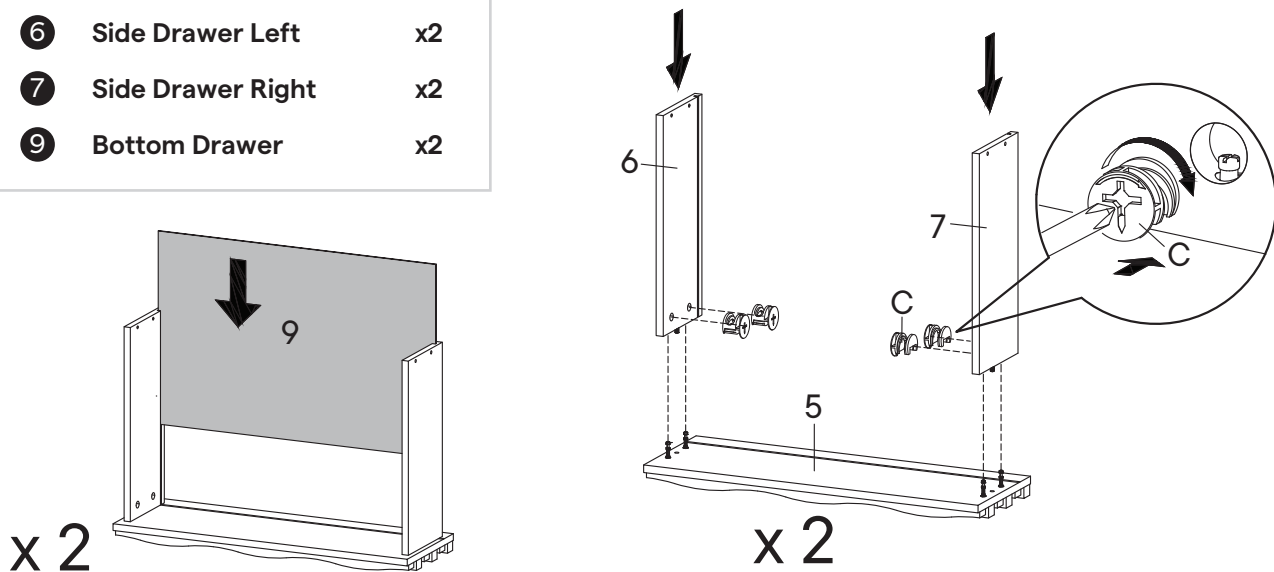

## HARDWARE

<b>G</b>	Screw M 3.5 x 13 mm	x12
<b>H</b>	Screw M 4 x 39 mm	x8
<b>RM35A</b>	Drawer Runner	x2

## COMPONENTS

<b>8</b>	Back Drawer	x2
----------	-------------	----

**3.1** Combine Back Drawer (8) to Pre - Assembly drawer from previous step, secure with Screw M 4 x 39 mm (H) then tighten using screwdriver, as shown in the picture.

**3.2** Install the Drawer Runner (RM35A) into position as shown in picture. Secure with Screw M 3.5 x 13 mm (G), then tighten screw using screwdriver.

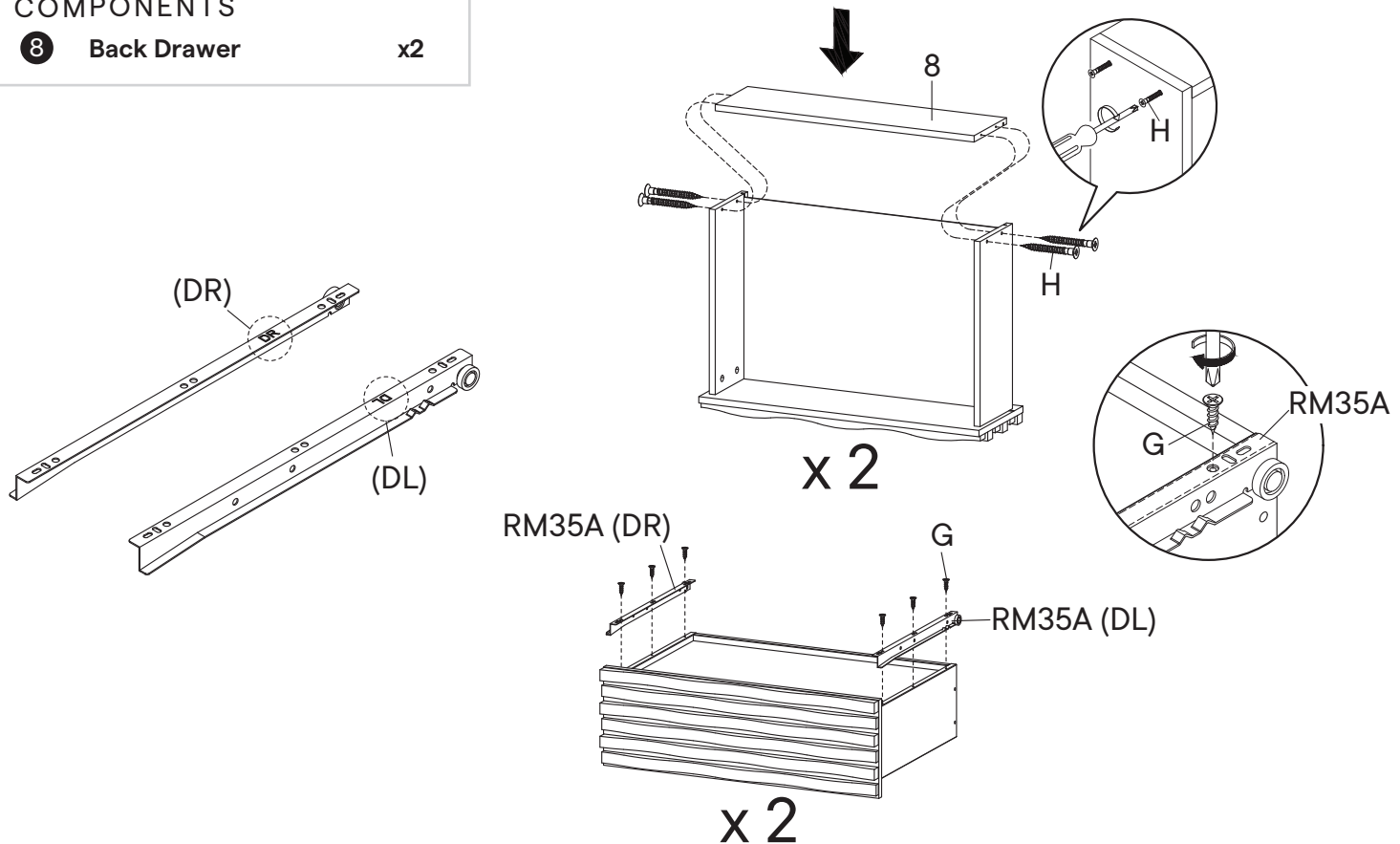

## STEP 04

## HARDWARE

<b>I</b>	Wedge	x8
<b>J</b>	Screw M 3.5 X 15.5 mm	x8

**4.1** Install the Wedge (I) and Screw M 3.5 x 15.5 mm (J) into bottom of the drawer according to the picture.

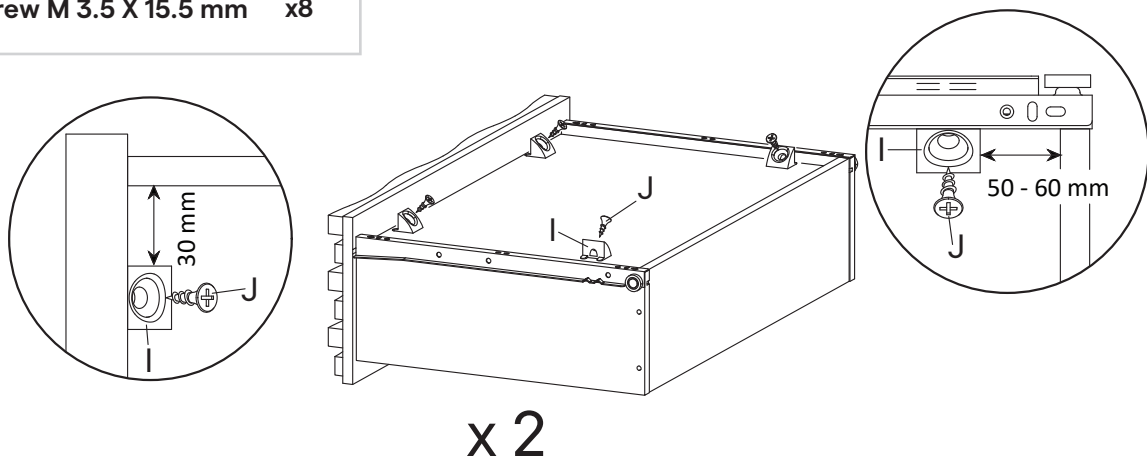

HARDWARE

- A** Cam Bolt Ø6 x 35 mm x8
- K** Floor Glide x4

COMPONENTS

- 3** Side Board Left x1
- 4** Side Board Right x1

**5.1** Insert Cam Bolt Ø6 x 35 mm (A) to Side Board Left (3) then secure with screwdriver and Insert Floor Glide (K), as shown in the picture.

**5.2** Insert Cam Bolt Ø6 x 35 mm (A) to Side Board Right (4) then secure with screwdriver and Insert Floor Glide (K), as shown in the picture.

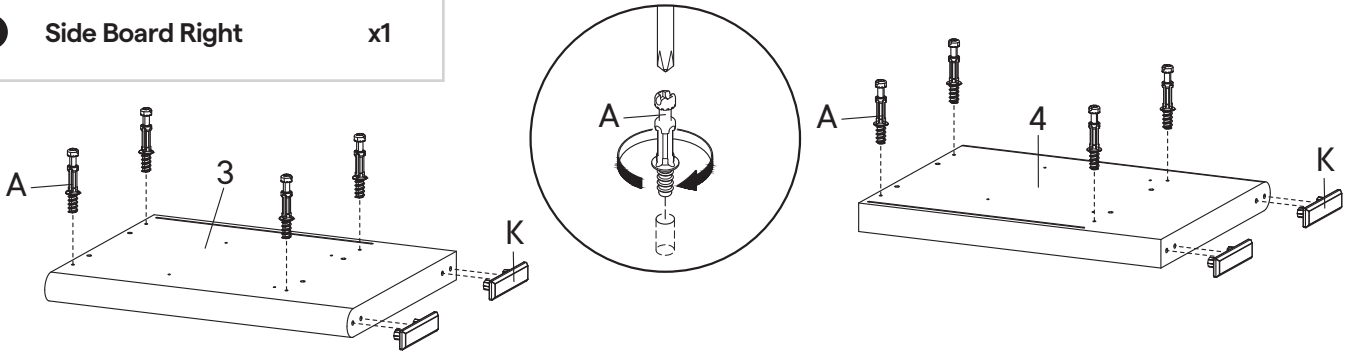

STEP 06

HARDWARE

- L** Screw M 6 x 10.5 mm x8
- RM35A** Drawer Runner x2

COMPONENTS

- 3** Side Board Left x1
- 4** Side Board Right x1

**6.1** Securing part of the Drawer Runner (RM35A) (CL) into Side Board Left (3) position as the above image, secure with screw M 6 x 10.5 mm (L). Then tighten screw using screwdriver.

**6.2** Securing part of the Drawer Runner (RM35A) (CR) into Side Board Right (4) position as the above image, secure with screw M 6 x 10.5 mm (L). Then tighten screw using screwdriver.

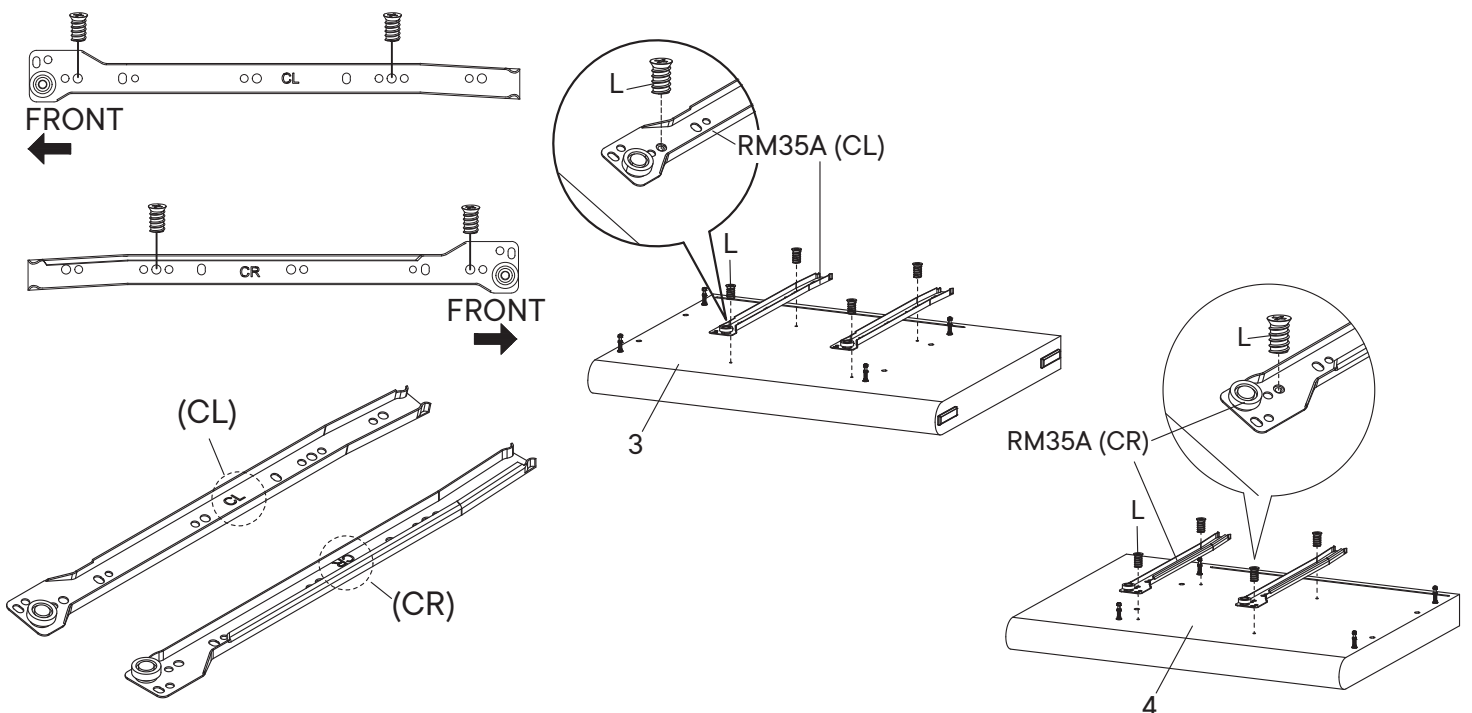

## HARDWARE

Ⓓ Wood Dowel Ø8 x 30 mm x8

## COMPONENTS

① Top Board x1

② Bottom Board x1

7.1 Insert Wood Dowel Ø8 x 30 mm (D) into the Top Board (1) and Bottom Board (2).

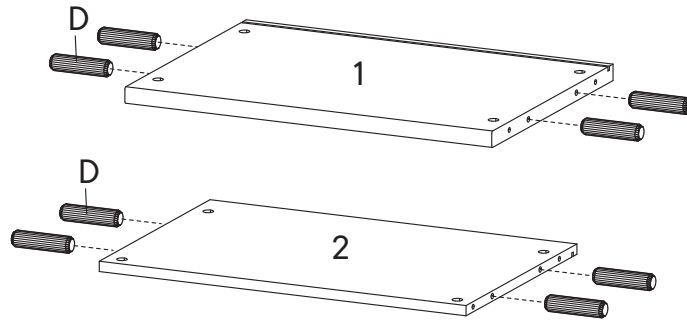

## STEP 08

## HARDWARE

Ⓑ Cam Lock Ø15 mm x4

## COMPONENTS

① Top Board x1

② Bottom Board x1

④ Side Board Right x1

⑩ Back Board x1

8.1 Combine Top Board (1) and Bottom Board (2) into Side Board Right (4) according to picture, and Insert Cam Lock Ø15 mm (B), then tighten using screwdriver. Position as shown in the figure.

8.2 Insert Back Board (10) into Side Board Right, with laminated face facing outside. Position as shown in the figure.

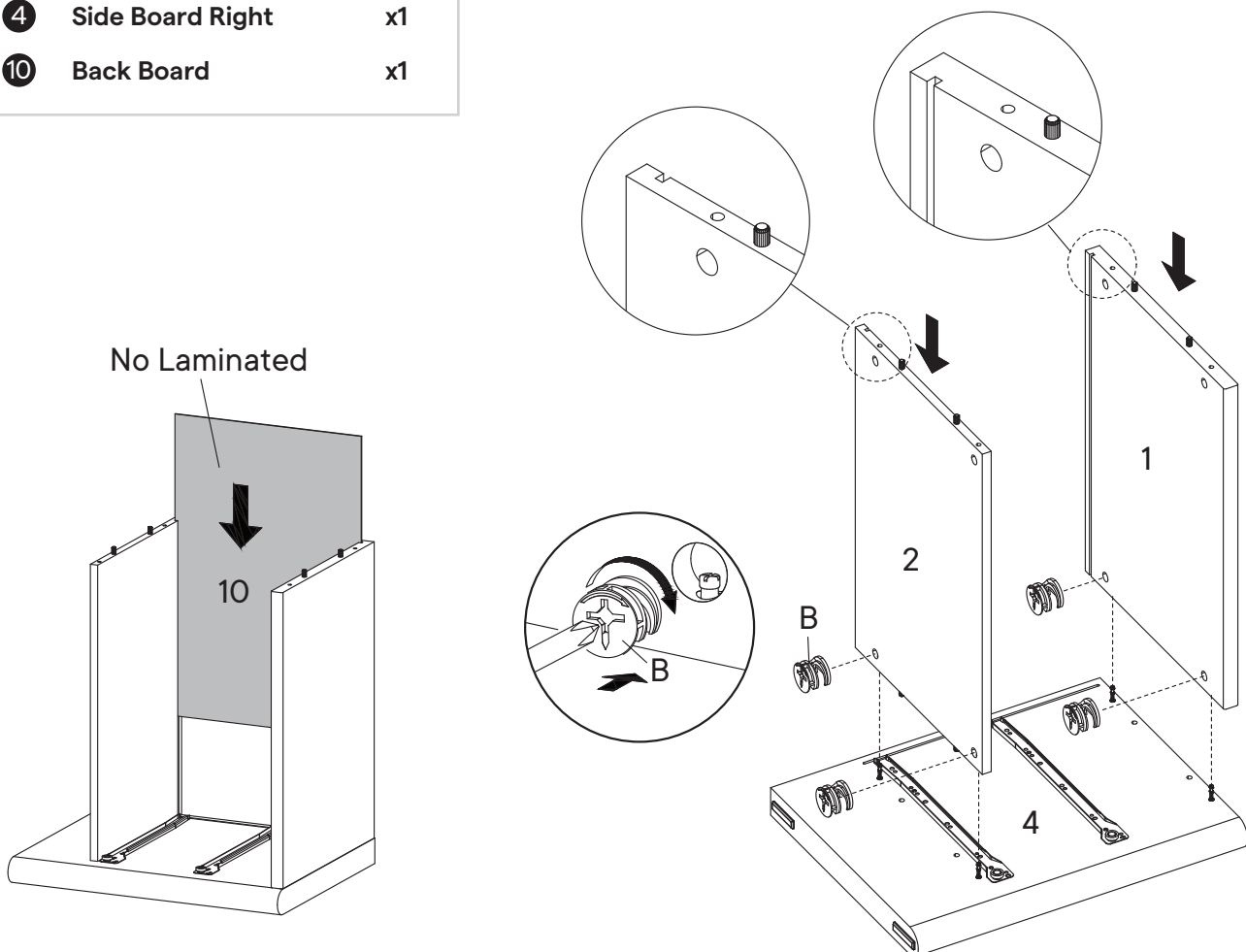

## HARDWARE

**B** Cam Lock Ø15 mm x4

## COMPONENTS

**3** Side Board Left x1

**9.1** Combine Side Board Left (3) and the component has been previously assembled. Secure with Cam Lock Ø15 mm (B), then tighten using screwdriver.

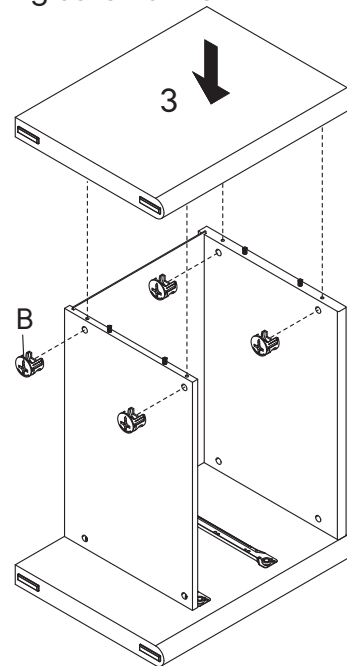
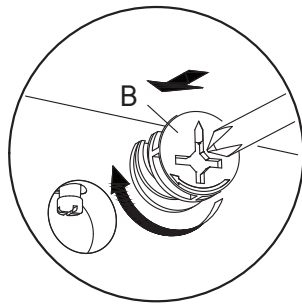

## STEP 10

**10.1** Hold the sides of drawer, position the wheel of rail at drawer back and the wheel of rail at side boards, according to the image. Slide in the drawers one by one into the nightstand.

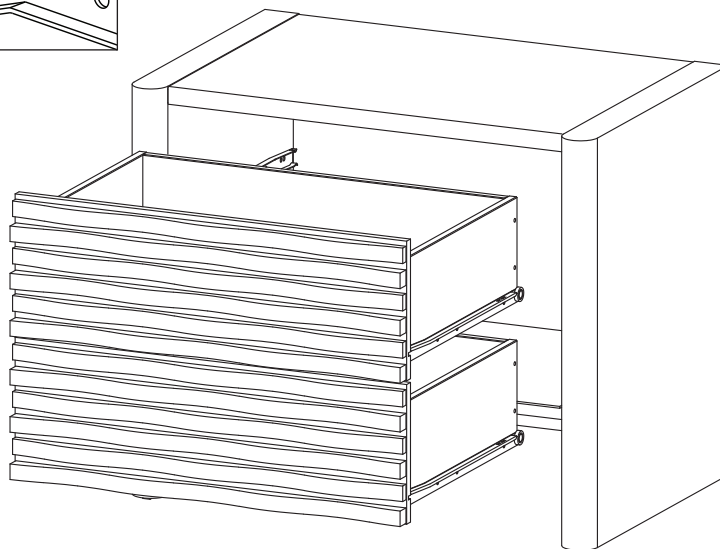
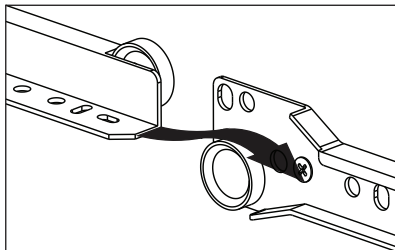

## HARDWARE

- I** Wedge x6
- J** Screw M 3.5 x 15.5 mm x6

**11.1** Use the Wedge (I) and Screw M 3.5 x 15.5 mm (J) to back of the nightstand then tighten with screwdriver. Before securing the Wedge (I), ensure that the top board and bottom board are aligned at a 90° angle against the nightstand.

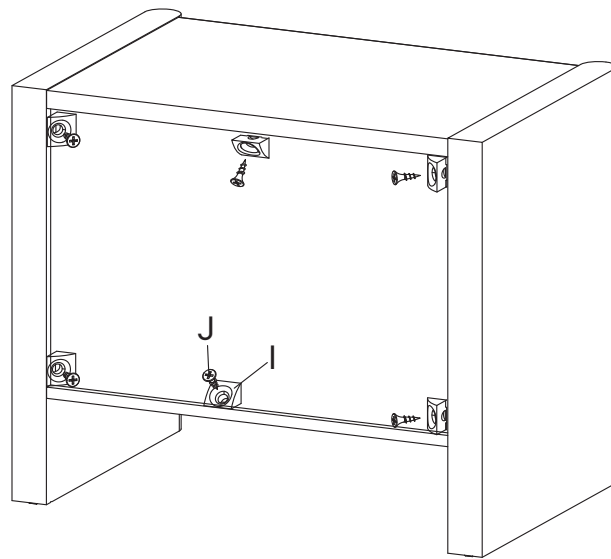
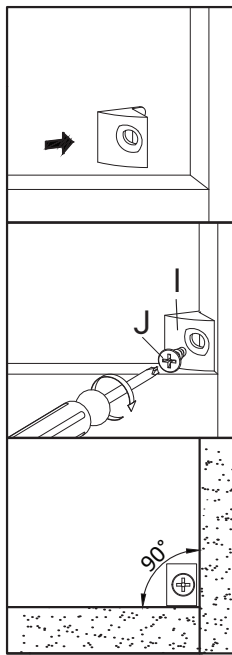

# Great job!

Nightstand assembly is complete

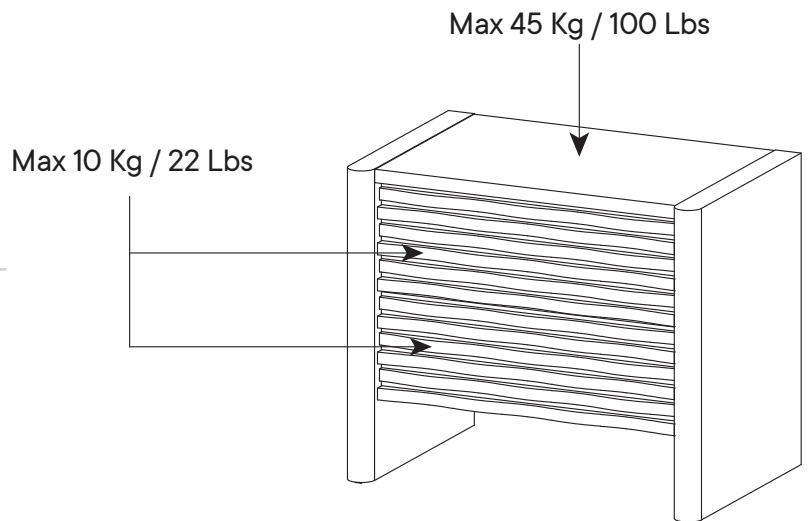

## CARING FOR YOUR ITEM

- Indoor use only.
- Not contract grade.
- Clean using a non-abrasive cloth and a mild cleaner.
- Never use harsh chemicals, as they could damage the finish or integrity of the item.



## CONNECT WITH US!

Tag us [@modway\\_furniture](#) and [#modway](#) for a chance to be featured.

# modway



Questions? Contact us!  
609.256.9000  
[cs@modway.com](mailto:cs@modway.com)