

USE & CARE GUIDE



Undercounter Ice Machine



Contents

Undercounter Ice Machine	3
Ice Machine Models	4
Ice Machine Operation	5
Ice Machine Care	9
Troubleshooting Guide	12
Service Information	13
Sub-Zero Warranties	14

Features and specifications are subject to change at any time without notice. Visit our website, subzero.com for the most up-to-date information.

Important Note

To ensure the safe and efficient use of Sub-Zero equipment, please take note of the following types of highlighted information throughout this guide:

IMPORTANT NOTE highlights information that is especially important.

CAUTION signals a situation where minor injury or product damage may occur if instructions are not followed.

WARNING states a hazard that may cause serious injury or death if precautions are not followed.



Thank You

Thank you for purchasing your new Sub-Zero undercounter ice machine. With Sub-Zero, you can rely on a 60-year tradition of quality and reliability.

Your Sub-Zero is protected by a warranty that is one of the finest in the industry. Take a moment to read the warranty statement at the end of this guide and refer to it should service become necessary.

This use & care guide will answer most of your questions about the features, operation and maintenance of your undercounter ice machine. If you have questions that are not addressed here, call Sub-Zero customer care at 800-222-7820 or visit our website, subzero.com.

If service should become necessary, you will need the model and serial numbers of the ice machine. Both numbers are listed on the product rating plate, located in the upper left corner of the ice bin and on the back of the unit. Refer to the illustration below.

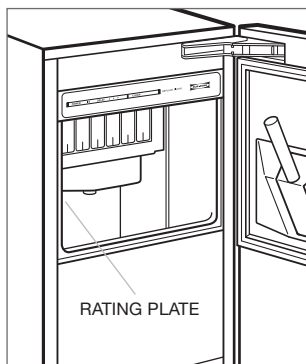

Location of rating plate.

BEFORE OPERATING

It is important to clean and sanitize the ice machine prior to use for optimum ice quality. To ensure proper operation, follow the operational checks on pages 7–8.

Due to regulatory restrictions, cleaner and sanitizer do not ship with the ice machine. Cleaner and sanitizer can be ordered online at subzerowolfstore.com. For questions, contact Sub-Zero customer care at 800-222-7820.

IMPORTANT NOTE: Adjustments and cleaning and maintenance procedures outlined in this guide are not covered by the warranty.

⚠ WARNING

Do not store food or beverages in the ice machine.

⚠ WARNING

Do not operate equipment that has been misused, neglected, damaged, altered or modified from that of original manufactured specifications.

Ice Machine Features

- High-volume ice machine—great for entertaining.
- Models UC-15IPO and UC-15IO UL approved for outdoor use up to 110°F (45°C).
- Produces up to 50 lbs (23 kg) of ice per day with large-capacity storage.
- Automatic ice maker provides quality, octagonal-shaped ice.
- Advanced water filtration system.
- Produces ice in air temperature up to 100°F (40°C)—up to 110°F (45°C) for outdoor models.
- Easy-access control panel.
- Two, four or eight hour delay feature.
- Clean and change filter indicator lights.
- Bin light.
- Ice scoop fits neatly in door.
- Automatic defrost.
- Drain pump for models UC-15IP and UC-15IPO—models UC-15I and UC-15IO use a gravity drain.
- UL approved for US and Canada.
- Two, five and twelve year residential warranty—exclusions apply, see warranty at the end of this guide.

Models UC-15I(P) and UC-15I(P)O ICE MACHINE

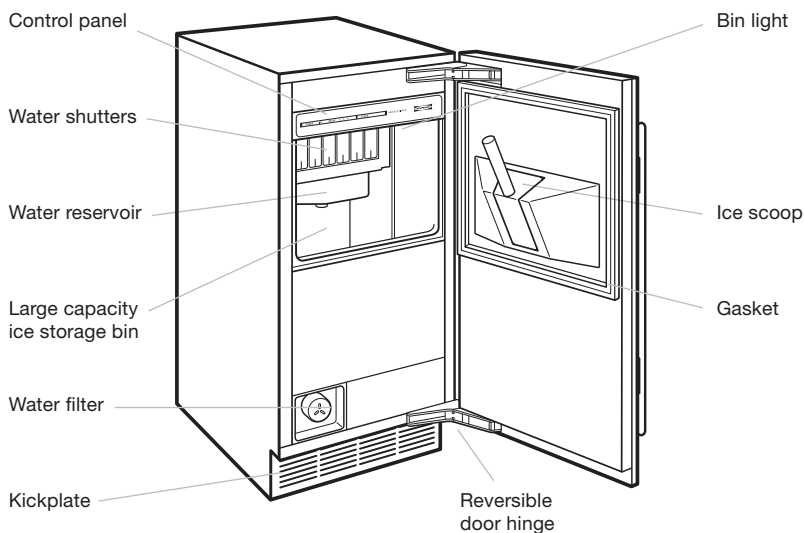

Control Panel

POWER KEY PAD

Press the POWER key pad once to activate the ice machine and the green POWER light. Press the POWER key pad a second time to deactivate the ice machine.

ICE LIGHT

The blue ICE light is illuminated when the ice machine is in ice making operation. The light is off when the ice machine is in the clean cycle.

DELAY KEY PAD

Press the DELAY key pad to initiate a delay period. The ice machine will not produce ice until the delay period has expired.

- Press the key pad once to illuminate the 2-hour light and initiate a two hour delay period.
- Press the key pad a second time to illuminate the 4-hour light and initiate a four hour delay period.
- Press the key pad a third time to illuminate the 8-hour light and initiate an eight hour delay period.
- Press the key pad a fourth time will cancel the delay period.

CLEAN KEY PAD

Press the CLEAN key pad to initiate a cleaning cycle. The ICE light will be deactivated. The green CLEAN light will flash during the cleaning cycle to indicate the proper time to add cleaner or sanitizer to the ice machine.

REPLACE FILTER LIGHT

When the ice machine completes 8000 freeze and harvest cycles, the red REPLACE FILTER light will illuminate to indicate the filter needs replacing. Depress the CLEAN key pad for six seconds to reset the counter and light.

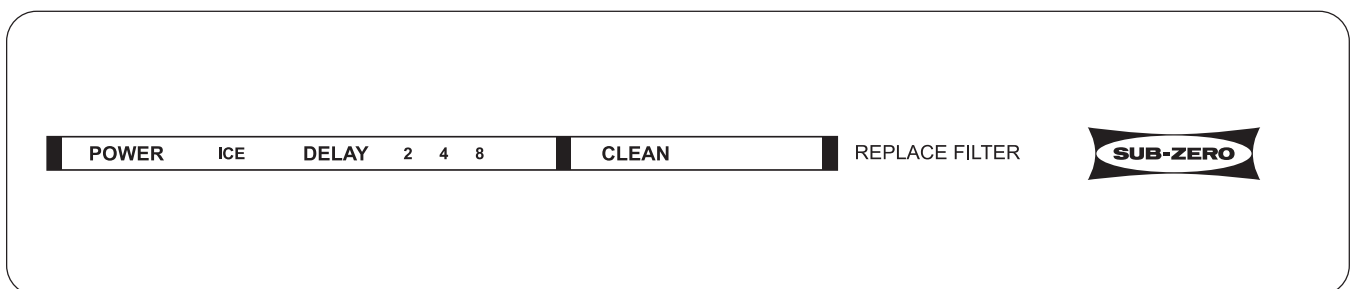

Control panel.

Ice Making Operation

Depending on ambient conditions and cold water supply temperature, the ice making process will take approximately 30 minutes.

- 1) **Water fill cycle.** (Initial start-up or start-up after automatic shut-off.) Before the compressor starts, the water inlet valve will purge old water from the system for about three minutes.
- 2) **Refrigeration system start-up.** The compressor starts after the water fill cycle and remains on throughout the freeze and harvest cycles. The condenser fan motor starts and runs throughout the freeze cycle.
- 3) **Freeze cycle.** The water pump sprays water into the inverted cups. The water freezes layer by layer, until an ice cube forms in each cup. The control system will adjust the length of the freeze cycle to conditions.
- 4) **Harvest cycle.** The water pump shuts off and the water inlet valve starts up to assist harvest and refill the water sump. The evaporator is warmed, allowing the cubes to release from the evaporator and drop into the storage bin. The control system will adjust the length of the harvest cycle to conditions and regulate whether the condenser fan will run. At the end of the harvest cycle, the ice machine will start another freeze cycle.
- 5) **Automatic shut-off.** The level of ice in the storage bin controls the automatic shut-off. When the bin is full, ice will contact the bin thermostat clip. The bin thermostat clip cools, signaling the ice machine to stop ice production. When the ice level drops and ice no longer contacts the bin thermostat clip, it will warm. The increase in temperature will restart ice production.

Operational Checks

The ice machine is factory tested and adjusted before shipping. Normally, new installations do not require any adjustment. Routine adjustments and maintenance procedures are not covered by the warranty.

To ensure proper operation, follow the operational checks when starting the ice machine for the first time, after a prolonged out of service period and after cleaning and sanitizing.

WATER LEVEL

The ice machine maintains the correct water level. The water level is not adjustable.

BIN THERMOSTAT

The bin thermostat signals the ice machine to stop ice production when the bin is full. It is preset for normal ambient temperatures and adjustments are usually not necessary.

To check operation of the bin thermostat, place three ice cubes on the thermostat clip for about five minutes, ice production should stop. The ice machine should restart five minutes after the cubes are removed. Refer to the illustration below.

If ice production stops before the bin is full or continues after the bin is full, ambient temperatures are probably too high or too low. The level of ice can be adjusted by following the steps below. The bin thermostat control is located behind the kickplate. Refer to the illustration below.

- 1) To access the bin thermostat, remove the four screws attaching the kickplate and tilt forward to remove.
- 2) Turn the bin thermostat control to the left to decrease the level of ice or to the right to increase the level of ice in the bin before automatic shut-off.
- 3) Reinstall the kickplate.

⚠ WARNING

Power is supplied to ice machine during this procedure. Avoid contact with the fan blade and the electrical connections.

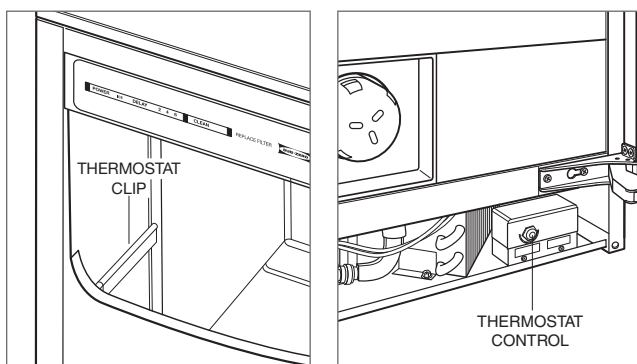

Bin thermostat clip.

Bin thermostat adjustment.

Operational Checks

CUBE WEIGHT

Cube weight increases or decreases depending on the amount of dimple in the cube. Refer to the illustration below. The cube weight can be increased from the factory setting by adjusting the finish time.

Check cube finishing time. Press and hold the POWER key pad for five seconds. Count the flashes on the ICE light. The light will flash once for each additional minute of freeze cycle time.

Adjust cube finishing time. Adjust in one minute increments and allow the ice machine to run several freeze and harvest cycles, then inspect the ice cubes. If a heavier cube weight is desired add another minute of freeze time and repeat the process.

- 1) Press and hold the POWER key pad.
- 2) Press and release the CLEAN key pad once for each additional minute of freeze cycle time desired. Five minutes is the maximum additional freeze time that can be added.
- 3) Press the CLEAN key pad six times to reset the finishing time to the original factory setting.

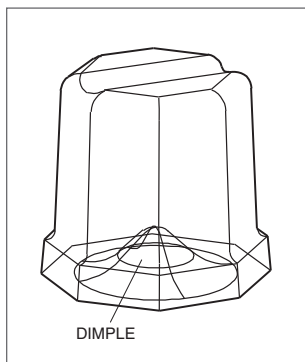

Cube weight.

Cleaning

Proper cleaning and maintenance of your ice machine will increase its reliability and performance and help minimize water and power consumption.

Due to regulatory restrictions, cleaner and sanitizer do not ship with the ice machine. Cleaner and sanitizer can be ordered online at subzerowolfstore.com. For questions, contact Sub-Zero customer care at 800-222-7820.

IMPORTANT NOTE: Poor water quality may require more frequent cleaning, sanitizing and water filter replacement.

Clean the entire unit including the cabinet exterior periodically. Also check the ice quality. To ensure reliable, trouble-free operation and maximum ice production, the following cleaning and maintenance should be performed every six months or after a prolonged shutdown.

- Sanitize ice storage bin (also before initial start-up).
- Clean condenser.
- Replace water filter.

To ensure efficient operation, an annual cleaning performed by Sub-Zero factory certified service is recommended. The ice machine will require disassembly, cleaning and sanitizing. For the name and number of Sub-Zero factory certified service, check the contact & support section of our website, subzero.com or call 800-222-7820.

Cleaning

CLEANING AND SANITIZING

Cleaning and sanitizing of all surfaces that come in contact with the water system should be performed every six months. The following steps outline the cleaning and sanitizing procedure with the ice machine in place.

Use only the cleaner and sanitizer made for your Sub-Zero ice machine. The cleaner removes lime scale or other mineral deposits and the sanitizer disinfects and removes algae and slime.

If the ice machine requires more frequent cleaning and sanitizing, consult a qualified professional to test the water quality and recommend appropriate water treatment. An abnormally dirty ice machine must be disassembled for proper cleaning and sanitizing by Sub-Zero factory certified service.

▲ CAUTION

Use only the Sub-Zero approved ice machine cleaner and sanitizer and follow all label directions and warnings. Damage to the ice machine evaporator caused by incorrect chemical usage is not covered by the warranty.

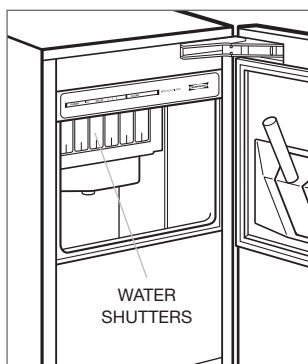

Location of water shutters.

- 1) Add 4 ounces (115 ml) of undiluted ice machine cleaner to a container that will fit under the lifted water shutters. Refer to the illustration below.
- 2) Press the CLEAN key pad. The ice machine will initiate a two minute harvest to remove any remaining ice from the evaporator.
- 3) Remove all ice from the bin.
- 4) Wait three minutes until the CLEAN light flashes, then add the prepared cleaner by lifting the water shutters and pouring directly into the spray area.
- 5) The ice machine will automatically time out a ten minute cleaning cycle, followed by eight rinse cycles, and stop. The CLEAN light will turn off to indicate the cleaning cycle is complete. This entire cycle lasts approximately 30 minutes.
- 6) Add 1 tablespoon (15 ml) of undiluted ice machine sanitizer to a container that will fit under the lifted water shutters.
- 7) Press the CLEAN key pad. Wait three minutes until the CLEAN light flashes, then add the prepared sanitizer by lifting the water shutters and pouring directly into the spray area. The ice machine will automatically time out a ten minute sanitizing cycle, followed by eight rinse cycles, and stop. The CLEAN light will turn off to indicate the sanitizing cycle is complete. This entire cycle lasts approximately 30 minutes.
- 8) The ice machine will automatically continue from the previous point before the cleaning cycle was initiated. If the ice machine was in the ice making cycle, the control board will start ice making again. If it was in the off cycle, the control board will turn off.

Cleaning

STAINLESS STEEL

To clean stainless steel surfaces of the ice machine, use a soft, nonabrasive stainless steel cleaner like Signature polish and apply with a soft lint-free cloth.

Signature polish is available from Signature Limited Laboratory, P. O. Box 13436, Dayton, Ohio 45413, or call 877-376-5474.

To bring out the natural luster of the stainless steel, lightly wipe the surface with a water-dampened microfiber cloth followed by a dry polishing chamois. All work should follow the grain direction of the finish. Better results are obtained by keeping the cloth in continuous contact with the stainless steel.

⚠ CAUTION

Do not use a metallic or highly abrasive cleaner or cloth, as this will scratch the stainless steel finish.

CONDENSER CLEANING

A dirty condenser restricts airflow, resulting in excessively high operating temperatures. This reduces ice production and shortens component life. The condenser should be cleaned every three to six months or after a prolonged shutdown.

The condenser of the ice machine is located at the bottom of the unit, behind the kickplate. Refer to the illustration below. To clean, follow these steps:

- 1) Remove the four screws attaching the kickplate and tilt forward. Clean kickplate openings before replacing.
- 2) Clean the outside of the condenser with a soft brush or a vacuum with a brush attachment. Clean from top to bottom, not side to side. Be careful not to bend the condenser fins.
- 3) Using a flashlight, check for dirt between the fins. If dirt remains between the fins or if the condenser fins are bent or flattened, contact Sub-Zero factory certified service.

⚠ CAUTION

Before cleaning the condenser, shut off power to the unit at the control panel. Wear gloves to avoid injury from sharp condenser fins.

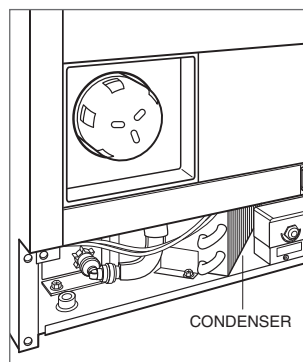

Vacuum condenser.

Maintenance

WATER FILTER REPLACEMENT

The water filter should be replaced every six months or after a prolonged shutdown. To replace the water filter, incoming water does not need to be turned off. The ice machine is equipped with an auto bypass feature which bypasses the filter when it is removed.

IMPORTANT NOTE: Poor water quality may require more frequent water filter replacement.

To remove, turn the water filter one-quarter turn counter-clockwise and it will pop out. Refer to the illustration below. Reverse the process to install the new water filter.

Replacement water filters can be ordered by calling 800-222-7820 or online at subzerowolfstore.com.

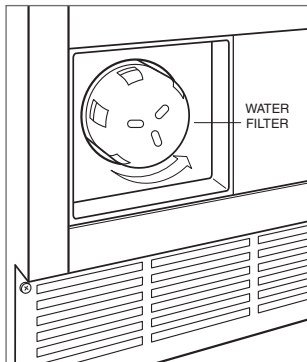

Water filter replacement.

PROLONGED SHUTDOWN AND WINTERIZATION

Special precautions must be taken if the ice machine is to be removed from service for an extended period of time or exposed to ambient temperatures of 32°F (0°C) or below.

Follow these steps:

- 1) Perform a cleaning and sanitizing procedure to prevent mildew growth.
- 2) Disconnect the electrical power at the circuit breaker or service panel.
- 3) Turn off the water supply.
- 4) Remove the water from the water reservoir.
- 5) Disconnect the incoming water supply line at the rear of the ice machine and allow it to drain.
- 6) Disconnect the vinyl hose from the water pump and allow it to drain.
- 7) Make sure water is not trapped in any of the water supply or drain lines. Compressed air can be used to blow out the lines.
- 8) Use a spray bottle with a solution of 1 tablespoon (15 ml) sanitizer to 1 gallon (3.8 L) water and spray all interior surfaces. Do not rinse, allow it to air dry.
- 9) Block the door partially open to provide air exchange and prevent mildew growth.

⚠ CAUTION

If water is allowed to remain in the ice machine in freezing temperatures, damage to some components could result. Damage of this nature is not covered by the warranty.

Troubleshooting

If your ice machine is not operating properly, use the following troubleshooting guide before contacting Sub-Zero factory certified service. This guide will save you time and trouble and may help you avoid the expense of a service call.

Ice machine does not operate.

- Press the POWER key pad to turn on the ice machine. Verify that it is plugged into a 115 V AC outlet.
- Check the household fuse or circuit breaker to see if it has been blown or tripped. A power outage may also have caused a disruption in service.
- Bin thermostat may need adjustment, refer to page 7.
- Drain pump safety switch is open. Verify that the line is not kinked or crimped before calling for service.

Ice machine operates, but no ice is produced.

- No water is being supplied to ice machine. Connect water supply.
- Incorrect incoming water pressure. Water pressure must be 20 psi (1.4 bar) to 80 psi (5.5 bar). If a reverse osmosis system is used to supply water, it may not provide adequate, constant water pressure.
- Spray nozzles blocked with mineral buildup. Clean and sanitize the ice machine, refer to page 9.
- Ambient air temperature is too high or too low. Ambient air temperature must be between 50°F (10°C) and 100°F (40°C) for indoor models and between 50°F (10°C) and 110°F (45°C) for outdoor models.
- Water filter is clogged. Replace water filter, clean and sanitize ice machine and clean condenser. Refer to pages 8–11.

Freeze cycle is long, low ice production.

- Water temperature is too high. Connect a cold water supply, verify that check valves in faucets and other equipment are functioning correctly.
- Dirty condenser. Clean condenser, refer to page 10.
- Vents in kickplate are obstructed. Remove obstruction.
- Ambient air temperature is too high. Ambient air temperature must be between 50°F (10°C) and 100°F (40°C) for indoor models and between 50°F (10°C) and 110°F (45°C) for outdoor models.
- Water filtration is poor. Replace water filter, refer to page 11.
- Water inlet valve is not working properly. Turn off ice machine. If water continues to enter ice machine, the water inlet valve must be replaced, contact Sub-Zero factory certified service.
- Refrigeration problem. Contact Sub-Zero factory certified service.

Poor ice quality, cubes are shallow, incomplete or white.

- Ice machine is dirty. Follow the cleaning and sanitizing procedure on page 9.
- Water filtration is poor. Replace water filter, refer to page 11.
- Water softener is not working properly (if applicable). Repair the water softener.
- Poor incoming water quality. Consult a qualified professional to test the water quality and recommend appropriate water treatment.

Service Information

If you do need service, be sure to have the model and serial number of your unit when you call. The numbers are listed on the product rating plate. Refer to the illustration on page 3 for location of the rating plate.

For warranty purposes, you will also need the date of installation and the name of your authorized Sub-Zero dealer. Record this information below for future reference.

Model Number _____

Serial Number _____

Installation Date _____

Sub-Zero Factory Certified Service

Phone _____

Authorized Sub-Zero Dealer

Phone _____

BEFORE CALLING FOR SERVICE

Before calling Sub-Zero factory certified service, refer to the troubleshooting guide on the previous page.

PRODUCT REGISTRATION

Register your new Sub-Zero today so that we may ensure your satisfaction. You may register by one of the following options:

- 1) Mail in the completed Sub-Zero product registration card.
- 2) Register online at subzero.com.
- 3) Register by phone by calling Sub-Zero customer care at **800-222-7820**.

The model and serial number of your unit are printed on the enclosed Sub-Zero product registration card. If you provide us with your e-mail address, we will send you exciting new product updates and recipes as they become available, along with information on special events.

The information and images in this guide are the copyright property of Sub-Zero, Inc. Neither this guide nor any information or images contained herein may be copied or used in whole or in part without the express written permission of Sub-Zero, Inc. ©Sub-Zero, Inc. all rights reserved.

Wolf, Wolf & Design, Wolf Gourmet, W & Design and the color red as applied to knobs are registered trademarks and service marks of Wolf Appliance, Inc. Sub-Zero, Sub-Zero & Design, Dual Refrigeration, Constant Care and The Living Kitchen are registered trademarks and service marks of Sub-Zero, Inc. (collectively, the "Company Marks.") All other trademarks or registered trademarks are property of their respective owners in the United States and other countries.

Sub-Zero Products Limited Warranty

FOR RESIDENTIAL USE ONLY

FULL TWO YEAR WARRANTY*

For two years from the date of original installation, your Sub-Zero product warranty covers all parts and labor to repair or replace, under normal residential use, any part of the product that proves to be defective in materials or workmanship. All service provided by Sub-Zero under the above warranty must be performed by Sub-Zero factory certified service, unless otherwise specified by Sub-Zero, Inc. Service will be provided during normal business hours.

FULL FIVE YEAR SEALED SYSTEM WARRANTY

For five years from the date of original installation, your Sub-Zero product warranty covers all parts and labor to repair or replace, under normal residential use, the compressor, condenser, evaporator, drier and all connecting tubing that prove to be defective in materials or workmanship. All service provided by Sub-Zero under the above warranty must be performed by Sub-Zero factory certified service, unless otherwise specified by Sub-Zero, Inc. Service will be provided during normal business hours.

LIMITED TWELVE YEAR SEALED SYSTEM WARRANTY

For twelve years from the date of original installation, your Sub-Zero product warranty covers all parts to repair or replace, under normal residential use, the compressor, condenser, evaporator, drier and all connecting tubing that prove to be defective in materials or workmanship.

TERMS APPLICABLE TO EACH WARRANTY

The warranty applies only to products installed for normal residential use. The warranty applies only to products installed in any one of the fifty states of the United States, the District of Columbia or the ten provinces of Canada. This warranty does not cover any parts or labor to correct any defect caused by negligence, accident or improper use, maintenance, installation, service or repair.

THE REMEDIES DESCRIBED ABOVE FOR EACH WARRANTY ARE THE ONLY ONES THAT SUB-ZERO, INC. WILL PROVIDE, EITHER UNDER THIS WARRANTY OR UNDER ANY WARRANTY ARISING BY OPERATION OF LAW. SUB-ZERO, INC. WILL NOT BE RESPONSIBLE FOR ANY CONSEQUENTIAL OR INCIDENTAL DAMAGES ARISING FROM THE BREACH OF THIS WARRANTY OR ANY OTHER WARRANTY, WHETHER EXPRESS, IMPLIED OR STATUTORY.

Some states do not allow the exclusion or limitation of incidental or consequential damages, so the above limitation or exclusion may not apply to you. This warranty gives you specific legal rights and you may also have other legal rights that vary from state to state.

To receive parts and/or service and the name of Sub-Zero factory certified service nearest you, contact Sub-Zero, Inc., P.O. Box 44848, Madison, WI 53744; check the contact & support section of our website, subzero.com or call 800-222-7820.

*Stainless steel doors, panels, handles, product frames and interior surfaces are covered by a limited 60-day parts and labor warranty for cosmetic defects.

*Replacement water filters and air purification cartridges are not covered by the product warranty.



Sub-Zero Outdoor Products Limited Warranty

PRODUCT MUST BE APPROVED FOR OUTDOOR USE, DESIGNATED BY MODEL AND SERIAL NUMBER
FOR RESIDENTIAL USE ONLY

FULL ONE YEAR WARRANTY*

For one year from the date of original installation, your Sub-Zero product warranty covers all parts and labor to repair or replace, under normal residential use, any part of the product that proves to be defective in materials or workmanship. All service provided by Sub-Zero under the above warranty must be performed by Sub-Zero factory certified service, unless otherwise specified by Sub-Zero, Inc. Service will be provided during normal business hours.

FULL FIVE YEAR SEALED SYSTEM WARRANTY

For five years from the date of original installation, your Sub-Zero product warranty covers all parts and labor to repair or replace, under normal residential use, the compressor, condenser, evaporator, drier and all connecting tubing that prove to be defective in materials or workmanship. All service provided by Sub-Zero under the above warranty must be performed by Sub-Zero factory certified service, unless otherwise specified by Sub-Zero, Inc. Service will be provided during normal business hours.

TERMS APPLICABLE TO EACH WARRANTY

The warranty applies only to products installed for normal residential use. The warranty applies only to products installed in any one of the fifty states of the United States, the District of Columbia or the ten provinces of Canada. This warranty does not cover any parts or labor to correct any defect caused by negligence, accident or improper use, maintenance, installation, service or repair.

THE REMEDIES DESCRIBED ABOVE FOR EACH WARRANTY ARE THE ONLY ONES THAT SUB-ZERO, INC. WILL PROVIDE, EITHER UNDER THIS WARRANTY OR UNDER ANY WARRANTY ARISING BY OPERATION OF LAW. SUB-ZERO, INC. WILL NOT BE RESPONSIBLE FOR ANY CONSEQUENTIAL OR INCIDENTAL DAMAGES ARISING FROM THE BREACH OF THIS WARRANTY OR ANY OTHER WARRANTY, WHETHER EXPRESS, IMPLIED OR STATUTORY.

Some states do not allow the exclusion or limitation of incidental or consequential damages, so the above limitation or exclusion may not apply to you. This warranty gives you specific legal rights and you may also have other legal rights that vary from state to state.

To receive parts and/or service and the name of Sub-Zero factory certified service nearest you, contact Sub-Zero, Inc., P.O. Box 44848, Madison, WI 53744; check the contact & support section of our website, subzero.com or call 800-222-7820.

*Stainless steel doors, panels, handles, product frames and interior surfaces are covered by a limited 60-day parts and labor warranty for cosmetic defects.

*Replacement water filters are not covered by the product warranty.





SUB-ZERO, INC. P. O. BOX 44848 MADISON, WI 53744 SUBZERO.COM 800.222.7820

7024817 REV-A 2/2012

