







ASSEMBLY INSTRUCTIONS

CROWN MARK (CRWN)

MODEL: B6520-K-HB/ B6520-Q-HB KING/ QUEEN HEADBOARD

THANK YOU FOR PURCHASING THIS QUALITY PRODUCT. BE SURE TO CHECK ALL PACKING MATERIAL CAREFULLY FOR SMALL PARTS WHICH MAY HAVE COME LOOSE INSIDE THE CARTON DURING SHIPMENT. IDENTIFY AND COUNT ALL PARTS AND COMPARE WITH HARDWARE LIST AS BELOW:

| (BOX 1) BOX OF HEADBOARD | | | |
|--------------------------|---|-------------------|-----|
| ITEM | DRAWING | DESCRIPTION | QTY |
| A |  | HEAD BOARD | 1 |
| B |  | HB LEG POST (L/R) | 2 |
| C |  | BOTTOM RAIL | 1 |

| (BOX 1) BOX OF HEADBOARD (HARDWARE LIST) | | | | |
|--|--|--|----------------|-----|
| ITEM | DRAWING | DESCRIPTION | DIMENSION | QTY |
| D |  | ALLEN KEY M5 | 5 X 35 X 120MM | 1 |
| E |  | ALLEN KEY M4 | 4 X 35 X 55MM | 1 |
| F |  | CONNECTION BOLT (JCBC M8x35mm) W/SPRING WASHER & WASHER MEDIUM | | 4 |
| G |  | CONNECTION BOLT (JCBC M6x35mm) W/SPRING WASHER & WASHER MEDIUM | | 2 |

STEP 1 : ATTACH AND TIGHTEN THE LEG POST (L/R) (B) TO THE HEADBOARD (A). INSERT CONNECTION BOLT (F) WITH WASHER TO AFFIX.

STEP 2: AFFIX THE BOTTOM RAIL (C) TO THE HEADBOARD LEG (B) USING CONNECTION BOLT (G) WITH WASHER.

NOTE: PERIODICALLY CHECK TO ENSURE THAT ALL CONNECTORS (BOLTS, SCREW, ETC) ARE TIGHT.

CLEANING INSTRUCTION
AFTER ASSEMBLED, CLEAN & POLISH THE COMPLETE PARTS IF NECESSARY WITH SOFT CLOTHES AND INDUSTRIAL RECOGNIZED FURNITURE POLISH.

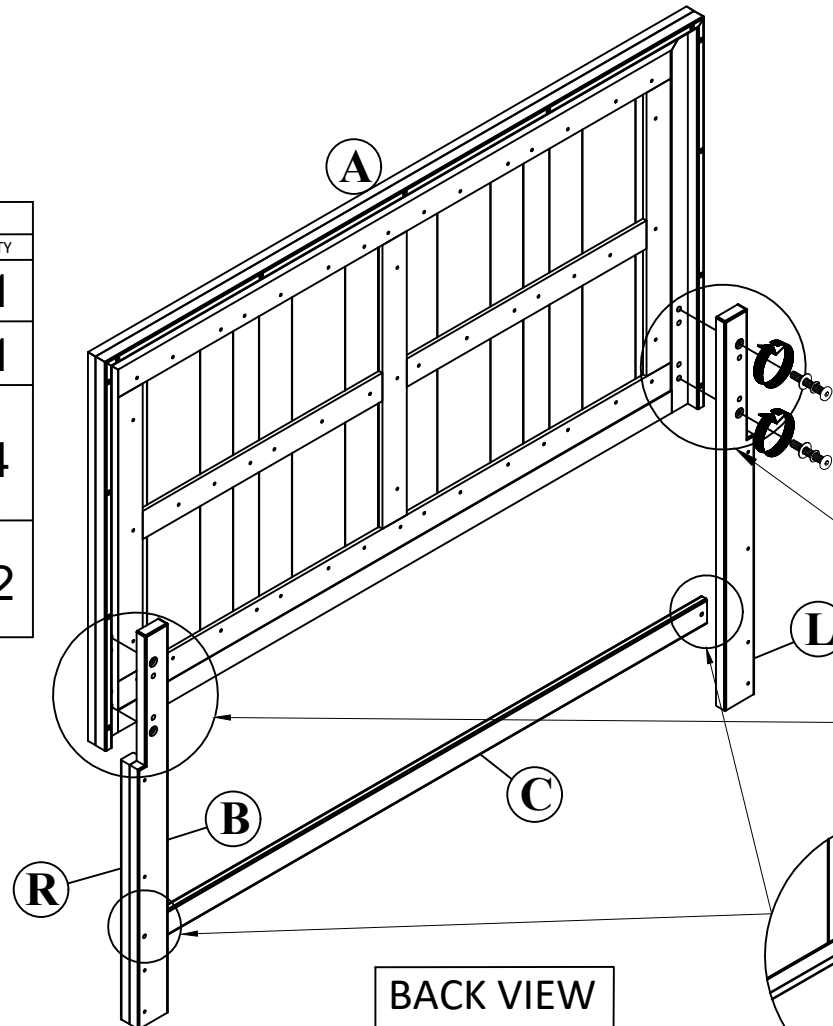

BACK VIEW

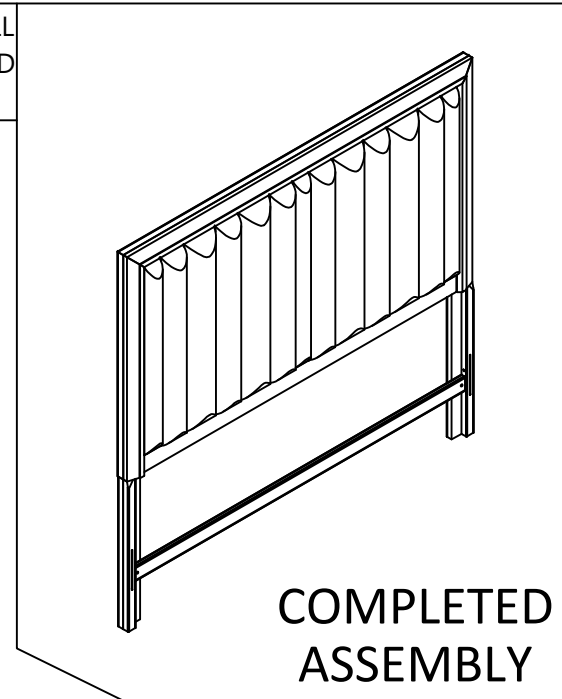

COMPLETED ASSEMBLY

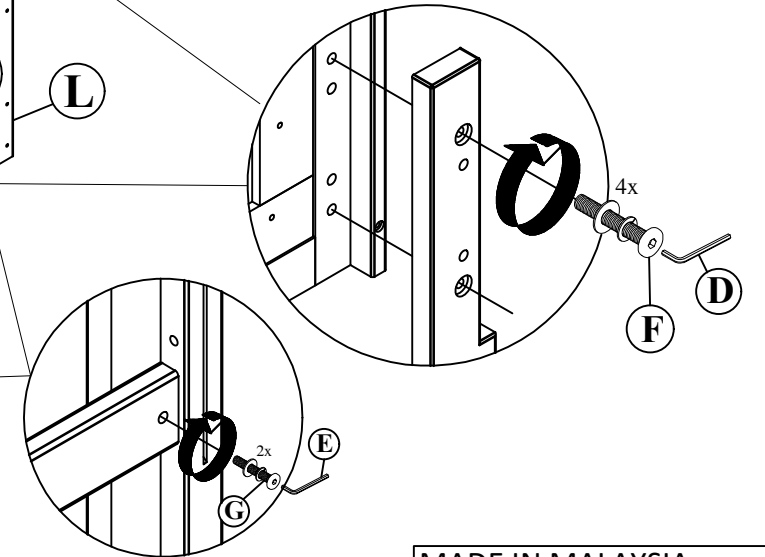

THE HARDWARE IS LOCATED IN THE PACKING ITEMS

MADE IN MALAYSIA

ASSEMBLY INSTRUCTIONS

CROWN MARK (CRWN)

MODEL: B6520-K-HB/B6520-K-FB/B6520-KQ-RAIL KING BED

THANK YOU FOR PURCHASING THIS QUALITY PRODUCT. BE SURE TO CHECK ALL PACKING MATERIAL CAREFULLY FOR SMALL PARTS WHICH MAY HAVE COME LOOSE INSIDE THE CARTON DURING SHIPMENT. IDENTIFY AND COUNT ALL PARTS AND COMPARE WITH HARDWARE LIST AS BELOW:

PART LIST

(BOX 1) BOX OF HEADBOARD

| ITEM | DRAWING | DESCRIPTION | QTY |
|------|---------|-------------|-----|
| A | | HEADBOARD | 1 |

(BOX 2) BOX OF FOOTBOARD

| ITEM | DRAWING | DESCRIPTION | QTY |
|------|---------|-------------|-----|
| B | | FOOTBOARD | 1 |

| ITEM | DRAWING | DESCRIPTION | QTY |
|------|---------|-------------|-----|
| C | | WOODEN SLAT | 5 |

| ITEM | DRAWING | DESCRIPTION | QTY |
|------|---------|---------------|-----|
| D | | SLATS SUPPORT | 10 |

(BOX 2) BOX OF FOOTBOARD HARDWARE LIST

| ITEM | DRAWING | DESCRIPTION | DIMENSION | QTY |
|------|---------|------------------|-----------|-----|
| E | | C.S.K. SCREW(M4) | 4 X 32MM | 10 |

(BOX 3) BOX OF SIDE RAILS

| ITEM | DRAWING | DESCRIPTION | QTY |
|------|---------|-------------|-----|
| F | | SIDE RAILS | 2 |

SCREW DRIVER IS NOT INCLUDED

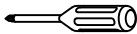

HAMMER IS NOT INCLUDED

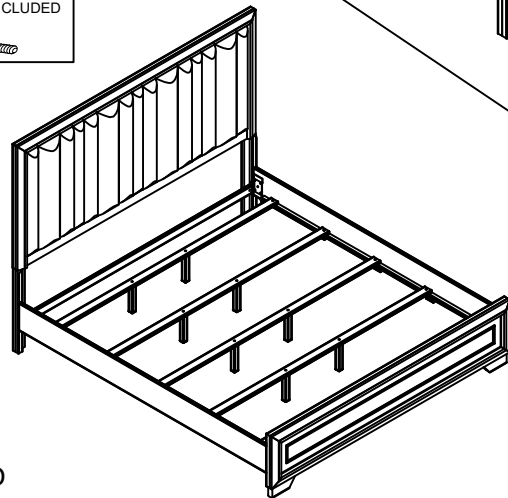

COMPLETED ASSEMBLY

NOTE: PERIODICALLY CHECK TO ENSURE THAT ALL CONNECTORS (BOLTS, SCREW, ETC) ARE TIGHT.

CLEANING INSTRUCTION
AFTER ASSEMBLED, CLEAN & POLISH THE COMPLETE PARTS IF NECESSARY WITH SOFT CLOTH AND INDUSTRIAL RECOGNIZED FURNITURE POLISH.

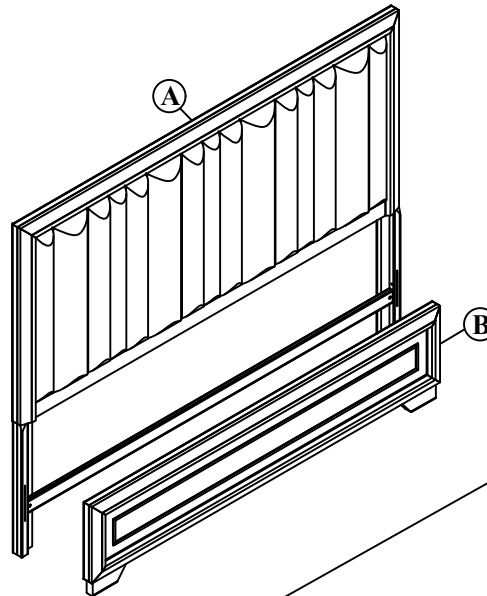

STEP 1 :

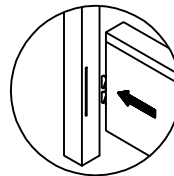

STEP 2 :

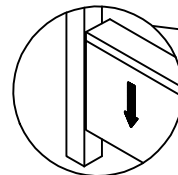

PRESS Laterally INTO THE GROOVE AND DROP DOWN.

STEP 3 :

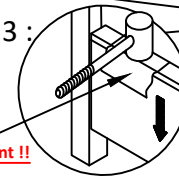

Important !!

LEVEL THE SIDE RAIL BY COVERING WITH A SOFT CLOTH AND TAPPING WITH A HAMMER.

STEP 5 :

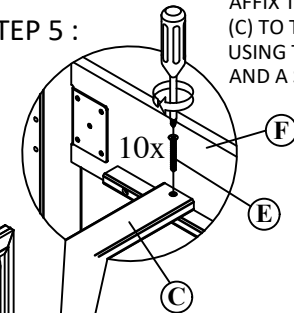

AFFIX THE WOODEN SLAT (C) TO THE SIDE RAIL (F) USING THE CSK SCREW (E) AND A SCREWDRIVER

STEP 4 :

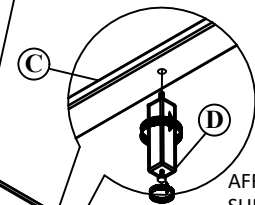

AFFIX THE SLAT SUPPORT (D) AND ADJUST HEIGHT FOR THE WOODEN SLAT (C)

THE HARDWARE IS LOCATED IN THE PACKING ITEMS

MADE IN MALAYSIA