

FREEMOTION[®]

OLYMPIC INCLINE BENCH

Model No. EF214.0

Serial No. _____

Write the serial number in the space above for reference.

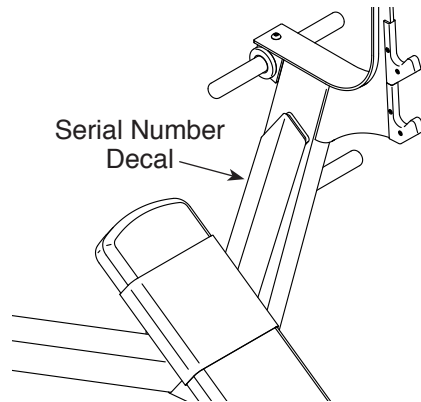

OWNER'S MANUAL

QUESTIONS?

If you have questions, or if parts are damaged or missing, please see HOW TO CONTACT CUSTOMER CARE on the back cover of this manual.

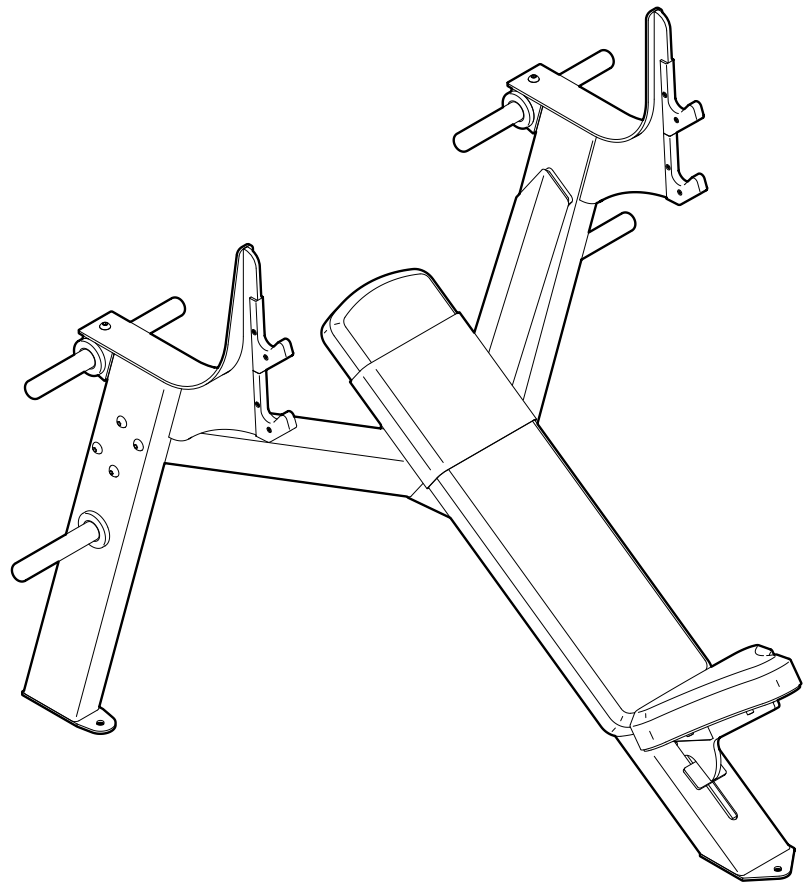

CAUTION

Read all precautions and instructions in this manual before using this equipment. Keep this manual for future reference.

TABLE OF CONTENTS



WARNING DECAL PLACEMENT	2
IMPORTANT PRECAUTIONS	3
BEFORE YOU BEGIN	4
PART IDENTIFICATION CHART	5
ASSEMBLY	6
ADJUSTMENT	9
MAINTENANCE AND TROUBLESHOOTING	10
PART LIST/EXPLODED DRAWING	11
HOW TO CONTACT CUSTOMER CARE	Back Cover
LIMITED WARRANTY	Back Cover

WARNING DECAL PLACEMENT

This drawing shows the location(s) of the warning decal(s). **If a decal is missing or illegible, see the back cover of this manual and request a free replacement decal. Apply the decal in the location shown.** Note: The decal(s) may not be shown at actual size.

WARNING

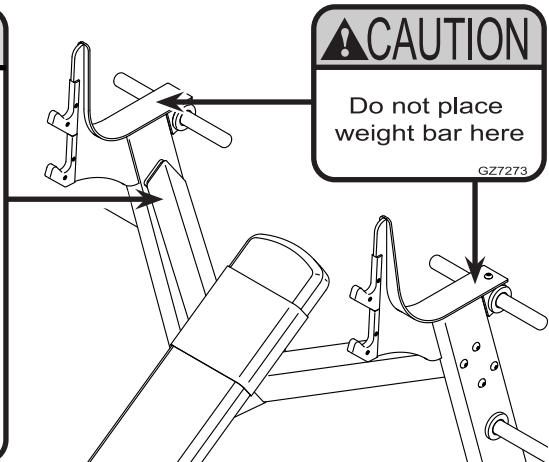
- Read and follow all warnings and instructions and obtain proper instruction prior to use.
- Misuse of this equipment may result in serious injury.
- Do not allow children on or around machine.
- Keep body, clothing, and hair free and clear of all moving parts.
- Replace label if damaged, illegible, or removed.
- Max user weight: 350 lbs.



FREEMOTION is a registered trademark of ICON Health & Fitness, Inc.
FORMULA 409 is a registered trademark of The Clorox Company.
SIMPLE GREEN is a registered trademark of Sunshine Makers, Inc.

IMPORTANT PRECAUTIONS

⚠️ WARNING: To reduce the risk of serious injury, read all important precautions and instructions in this manual and all warnings on your strength equipment before using your strength equipment. Freemotion Fitness assumes no responsibility for personal injury or property damage sustained by or through the use of this product.

1. It is the responsibility of the owner to ensure that all users of the strength equipment are adequately informed of all precautions, have read and understood all warning and caution labels, and are informed of how to use the strength equipment properly.
2. All users of the strength equipment should be instructed to report any injury or strength equipment irregularity to facility staff immediately.
3. Before beginning any exercise program, consult your physician. This is especially important for persons over age 35 or persons with pre-existing health problems.
4. Use the strength equipment only on a level surface. Cover the floor beneath the strength equipment to protect the floor.
5. It is the responsibility of the owner to ensure that there is enough space around the strength equipment for the intended exercise.
6. Using the anchor holes (see page 4), anchor the strength equipment to the floor to provide maximum stability.
7. Make sure that all parts are properly tightened before each use of the strength equipment.
8. Keep children under age 13 and pets away from the strength equipment at all times.
9. The strength equipment is designed to support a maximum user weight of 350 lbs. (159 kg); a maximum of 600 lbs. (272 kg) of weight, including a barbell; and a maximum total weight of 950 lbs. (431 kg). Note: The strength equipment does not include weights or a barbell.
10. Always wear athletic shoes for foot protection while exercising.
11. Always exercise with a partner. Your partner should be ready to catch the barbell if you cannot complete a repetition.
12. Use the strength equipment only as described in this manual.
13. Over exercising may result in serious injury or death. If you feel faint, if you become short of breath, or if you experience pain while exercising, stop immediately and cool down.

BEFORE YOU BEGIN

Thank you for selecting the FREEMOTION® OLYMPIC INCLINE BENCH strength equipment. The OLYMPIC INCLINE BENCH is designed to help you develop the major muscle groups of your upper body. Whether your goal is to tone your body or build dramatic muscle size and strength, the OLYMPIC INCLINE BENCH will help you to achieve the specific results you want.

For your benefit, read this manual carefully before you use the strength equipment. If you have

questions after reading this manual, please see the back cover of this manual. To help us assist you, note the product model number and serial number before contacting us. The model number and the location of the serial number decal are shown on the front cover of this manual.

Before reading further, please familiarize yourself with the parts that are labeled in the drawing below.

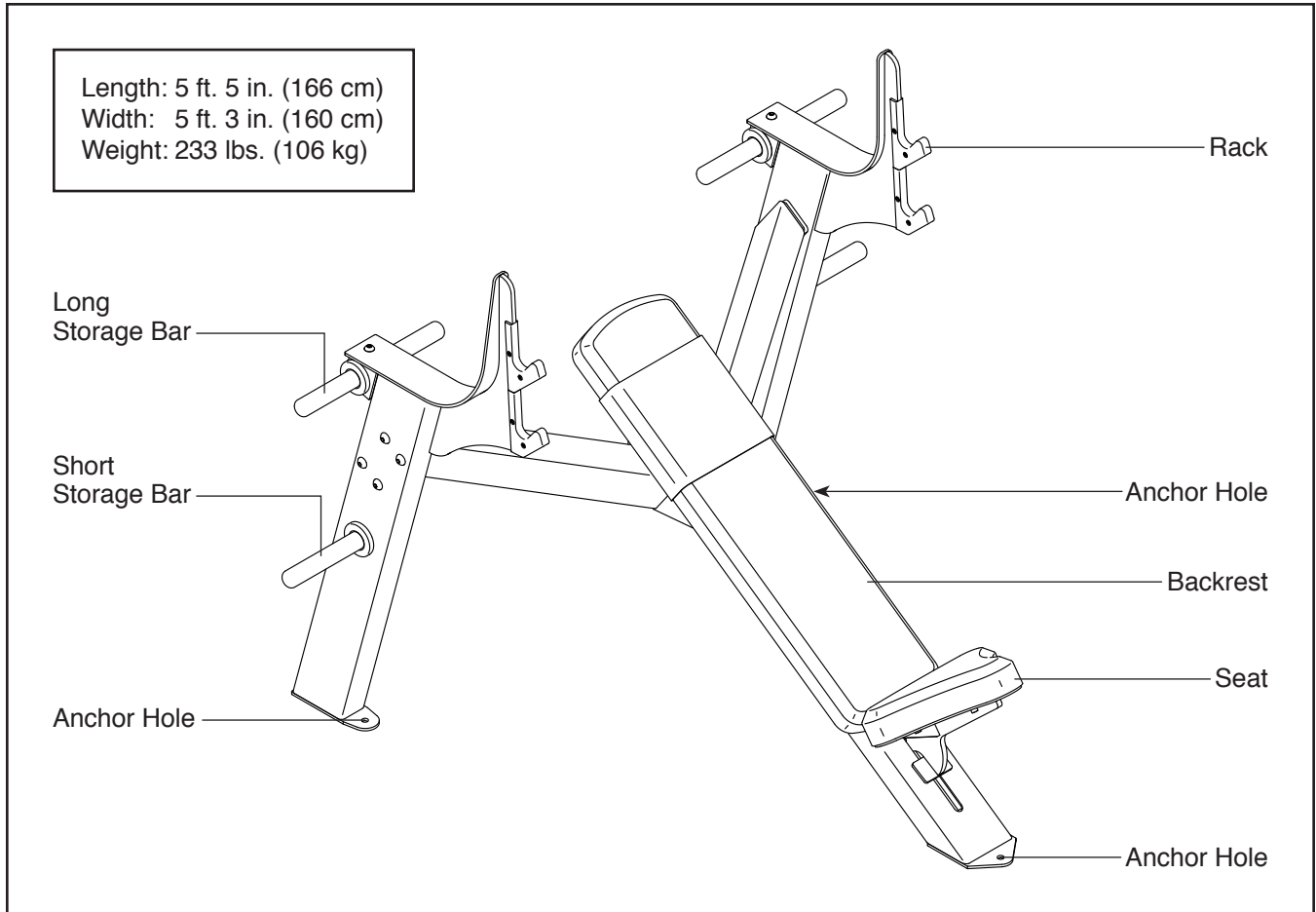

PART IDENTIFICATION CHART

This chart is provided to help you identify the small parts used in assembly. The number in parentheses below each part is the key number of the part from the PART LIST near the end of this manual. The number following the parentheses is the quantity needed for assembly. **IMPORTANT: If you cannot find a part in the hardware kit, check to see whether it has been preassembled.**

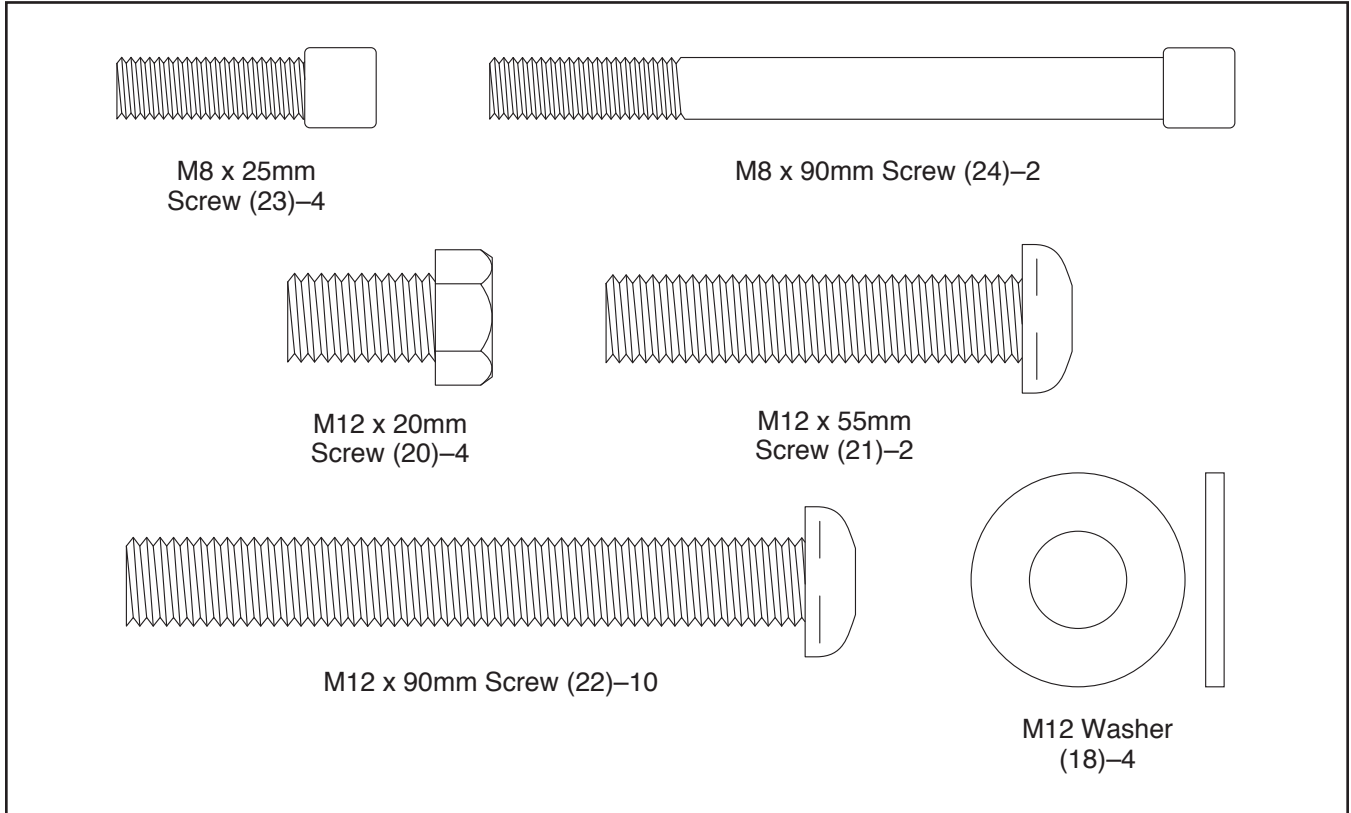

ASSEMBLY

- Assembly requires two persons.
- Because of its weight and size, assemble the strength equipment in the location where it will be used. Make sure that there is enough clearance to walk around the strength equipment.
- Place all parts in a cleared area and remove the packing materials. Do not dispose of the packing materials until you finish all assembly steps.
- Left parts are marked “L” or “Left” and right parts are marked “R” or “Right.”

- To identify small parts, see page 5.
- Assembly requires the following tool(s) (not included):

an adjustable wrench



a metric hex key



Assembly may be easier if you have a set of wrenches. To avoid damaging parts, do not use power tools.

1. Identify the Left Frame (3).

Attach the Left Frame (3) to the Center Frame (1) with two M12 x 20mm Screws (20) and two M12 Washers (18).

Attach the Right Frame (2) in the same way.

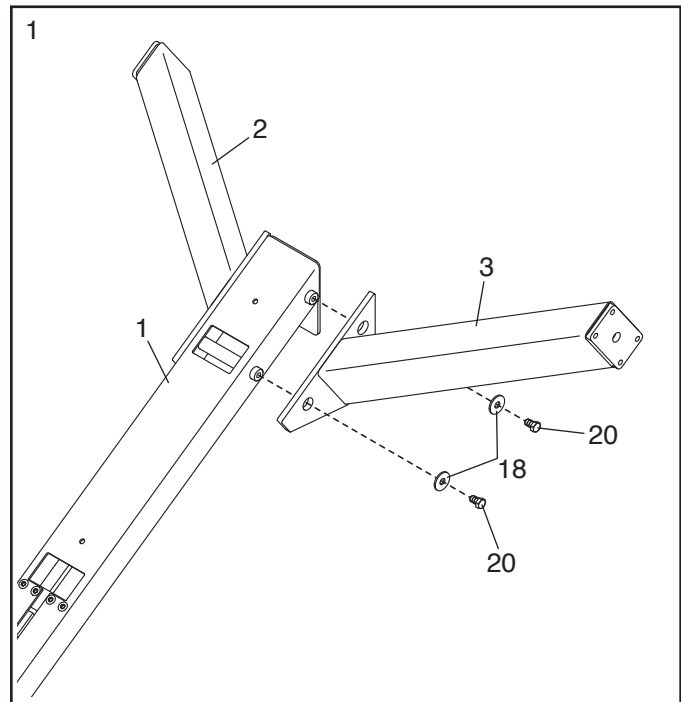

2. Identify the Left Upright (5).

Attach the Left Upright (5) to the Left Frame (3) with four M12 x 90mm Screws (22); **do not tighten the Screws yet.**

Attach the Right Upright (4) to the Right Frame (2) in the same way.

Make sure that the racks (A) on the Left and Right Uprights (5, 4) are aligned, and then tighten the eight M12 x 90mm Screws (22).

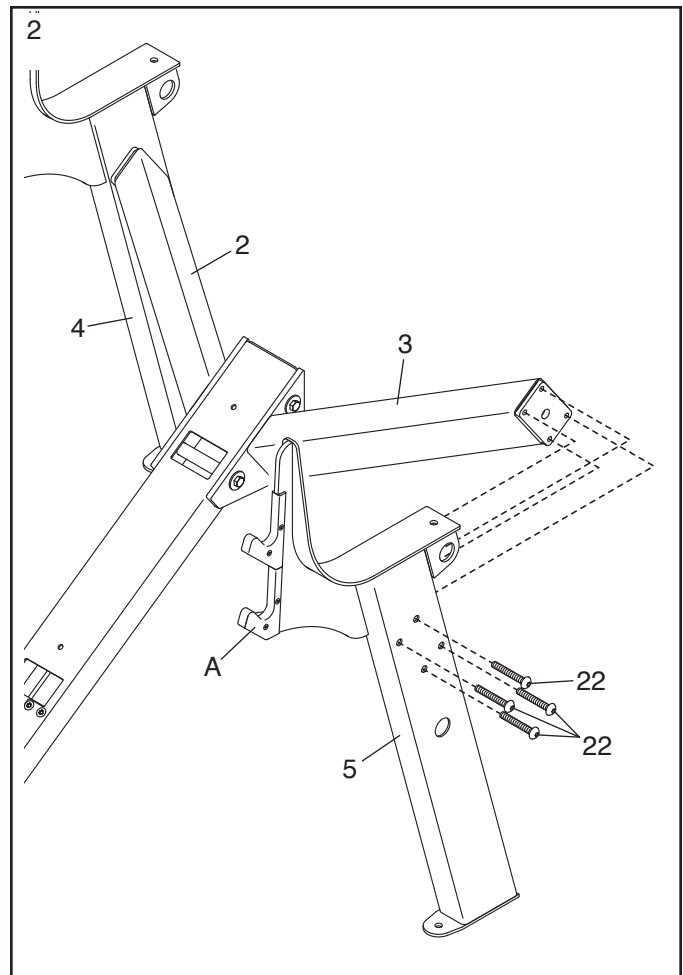

3. Attach a Short Storage Bar (11) to the Left Upright (5) with an M12 x 90mm Screw (22).

Next, slide a Weight Bumper (15) onto the Short Storage Bar (11).

Repeat this step on the other side of the strength equipment.

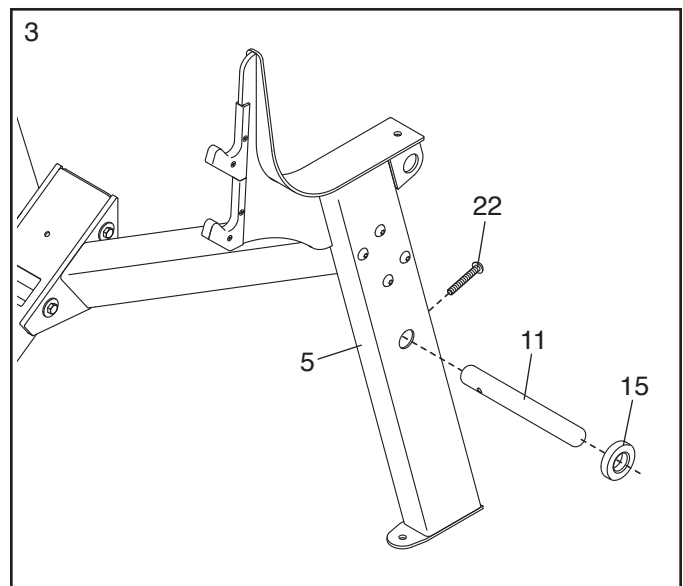

4. Attach a Long Storage Bar (12) to the Left Upright (5) with an M12 x 55mm Screw (21).

Next, slide two Weight Bumpers (15) onto the Long Storage Bar (12).

Repeat this step on the other side of the strength equipment.

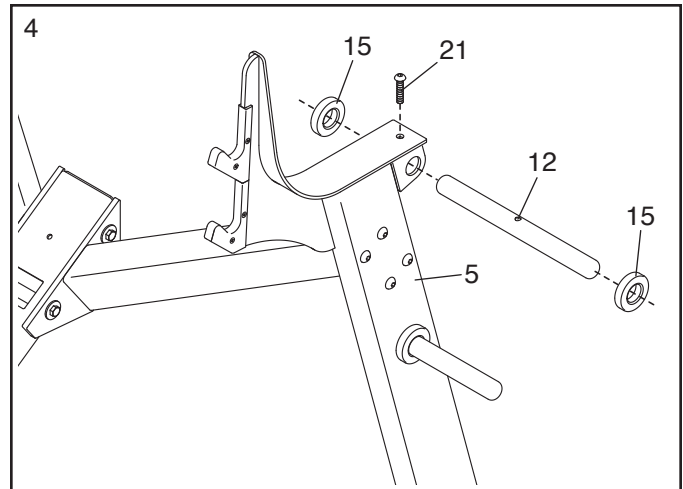

5. Attach the Backrest (9) to the Center Frame (1) with two M8 x 90mm Screws (24); **to avoid damaging the Backrest, tighten the Screws only until the Backrest does not move or feel loose.**

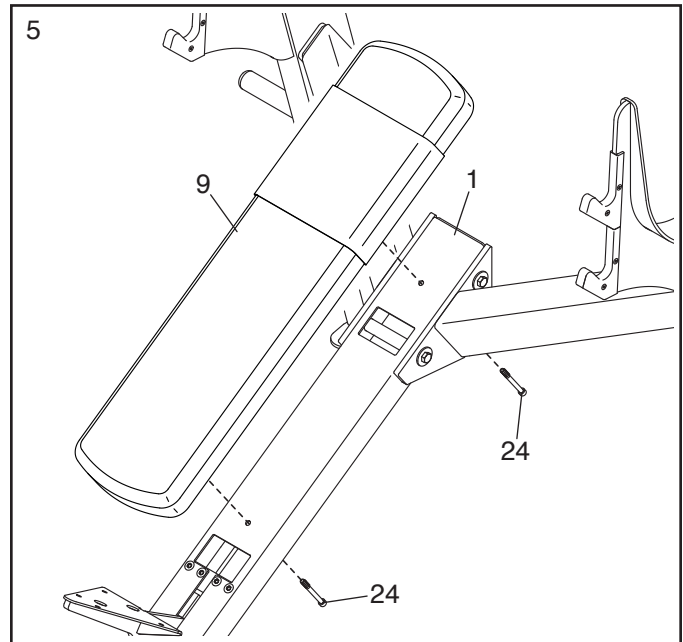

6. Attach the Seat (10) to the Seat Frame (6) with four M8 x 25mm Screws (23); **to avoid damaging the Seat, tighten the Screws only until the Seat does not move or feel loose.**

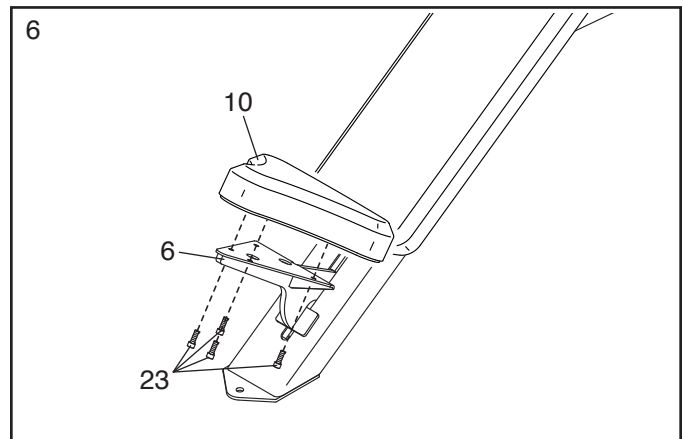

7. **Make sure that all parts of the strength equipment are properly tightened.** To protect the floor or carpet from damage, place a mat under the strength equipment.

ADJUSTMENT

This section explains how to adjust the strength equipment. **Make sure that all parts are properly tightened each time the strength equipment is used; replace any worn parts immediately.**

ADJUSTING THE SEAT

To raise the seat, lift the front (A) of the seat, slide the seat to the desired position, and then fully lower the front of the seat. **Make sure that the seat is secured in the new position.**

To lower the seat, lift the front (A) of the seat, push downward on the back (B) of the seat, and then fully lower the front of the seat. **Make sure that the seat is secured in the new position.**

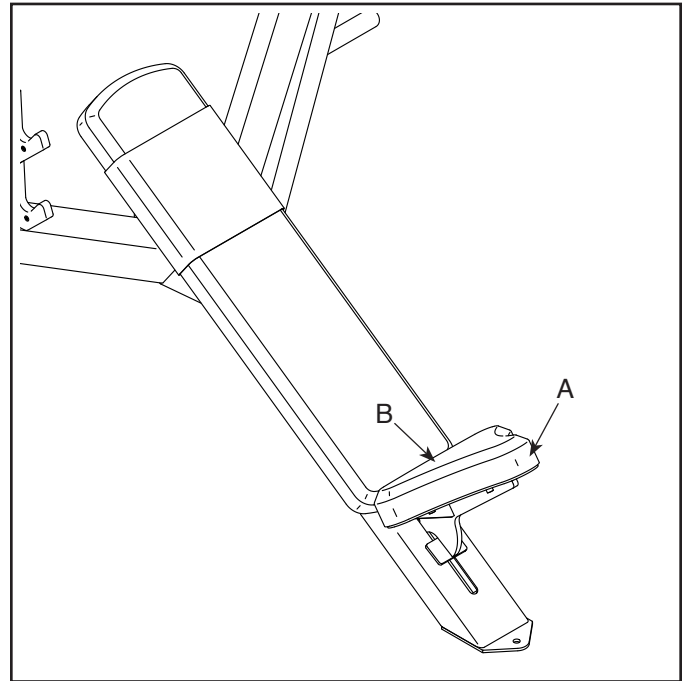

STORING WEIGHTS

Unused weights (not included) can be stored on the storage bars. Place lighter weights on the long (upper) storage bars (C). Place heavier weights on the short (bottom) storage bars (D).

⚠ WARNING: Each long storage bar (C) can hold up to 150 lbs. (68 kg). Each short storage bar (D) can hold up to 225 lbs. (102 kg). Do not place a total of more than 600 lbs. (272 kg), including a barbell (not included), on the racks and the storage bars. Always place the same amount of weight on both sides of your barbell.

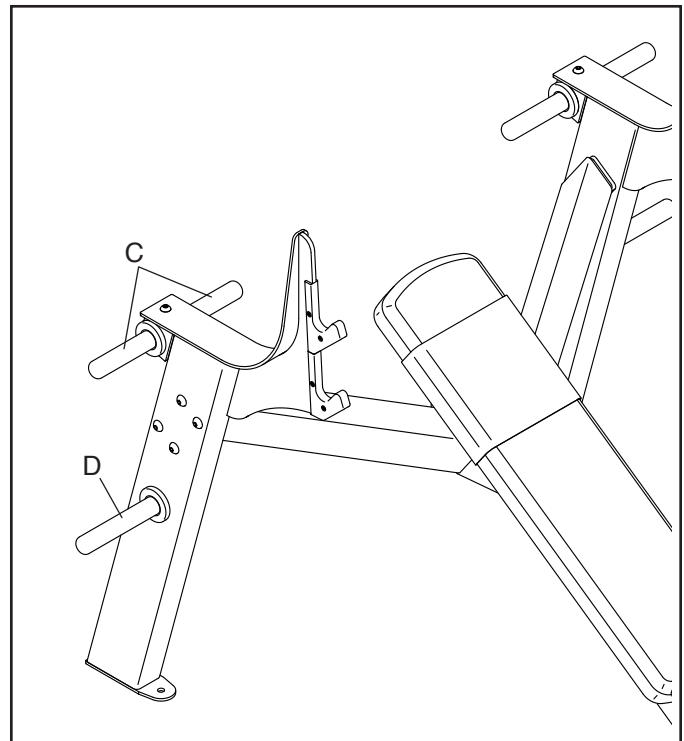

MAINTENANCE AND TROUBLESHOOTING

For optimal performance of the strength equipment and to reduce the chances of injury to users, you must perform preventive maintenance on a regular basis. Instruct all personnel to perform the procedures described in this section. Personnel must also record and report any accident. To maintain the strength equipment's warranty, use only FREEMOTION parts for repair or replacement. If there are any questions or concerns, see HOW TO CONTACT CUSTOMER CARE on the back cover of this manual.

DAILY MAINTENANCE

General Cleaning

Clean the strength equipment using a soft cloth dampened with a light solution of mild soap and warm water. If necessary, use a soft bristle brush with the cleaning solution.

Then, rinse the area thoroughly using a soft cloth dampened with clean water, and thoroughly dry it.

Difficult Stains

Spray the stain with a non-abrasive household cleaner such as FORMULA 409® cleaner, SIMPLE GREEN®, or a similar product. Rub the stained area gently and let the cleaning solution sit for a few minutes.

Then, rinse the area thoroughly using a soft cloth dampened with clean water, and thoroughly dry it.

Repeat these steps, if necessary, using a soft bristle brush.

Optional Method for Difficult Stains

Rub the stained area gently using a soft cloth dampened with rubbing alcohol.

Then, rinse the area thoroughly using a soft cloth dampened with clean water, and thoroughly dry it.

CAUTION: When using any cleaning product, try it first in an unnoticeable place to ensure that there is no damage to the material. Follow the directions and the safety precautions of the manufacturer of each cleaning product used. Freemotion Fitness and its vendors cannot be held liable for damage or injuries resulting from the use or misuse of cleaning products.

IMPORTANT: Do not use abrasive cleaners, which may scratch the strength equipment. Strong cleaners and abrasives will damage decals; use caution around decals. Do not use solvents such as lacquer thinner, kerosene, gasoline, or similar liquids.

WEEKLY MAINTENANCE

Hardware

Check all nuts and bolts, and tighten them if necessary. **IMPORTANT:** All FREEMOTION cushions have dense plywood supports with tee-nuts that are used to bolt the cushions to the strength equipment. Because the tee-nuts are held by the plywood, they will not withstand the torque that standard nuts and bolts will. When tightening the bolts securing a cushion, turn them only until they are snug and the cushion does not move or feel loose. Overtightening may strip the tee-nuts from the plywood and make it impossible to remove the cushion in the future.

PART LIST/EXPLODED DRAWING

Model No. EF214.0 R0419A

Key No.	Qty.	Description	Key No.	Qty.	Description
1	1	Center Frame	16	1	Seat Cord
2	1	Right Frame	17	2	Wire Tie
3	1	Left Frame	18	4	M12 Washer
4	1	Right Upright	19	16	M5 x 12mm Screw
5	1	Left Upright	20	4	M12 x 20mm Screw
6	1	Seat Frame	21	2	M12 x 55mm Screw
7	1	Seat Stop	22	10	M12 x 90mm Screw
8	2	Seat Frame Pin	23	4	M8 x 25mm Screw
9	1	Backrest	24	2	M8 x 90mm Screw
10	1	Seat	25	2	M10 x 20mm Flat Head Screw
11	2	Short Storage Bar	26	4	M10 x 16mm Flat Head Screw
12	2	Long Storage Bar	27	1	Backrest Wear Cover
13	2	Upper Rack Cover	*	-	Owner's Manual
14	2	Lower Rack Cover			
15	6	Weight Bumper			

Note: Specifications are subject to change without notice. For information about ordering replacement parts, see the back cover of this manual. *These parts are not illustrated.

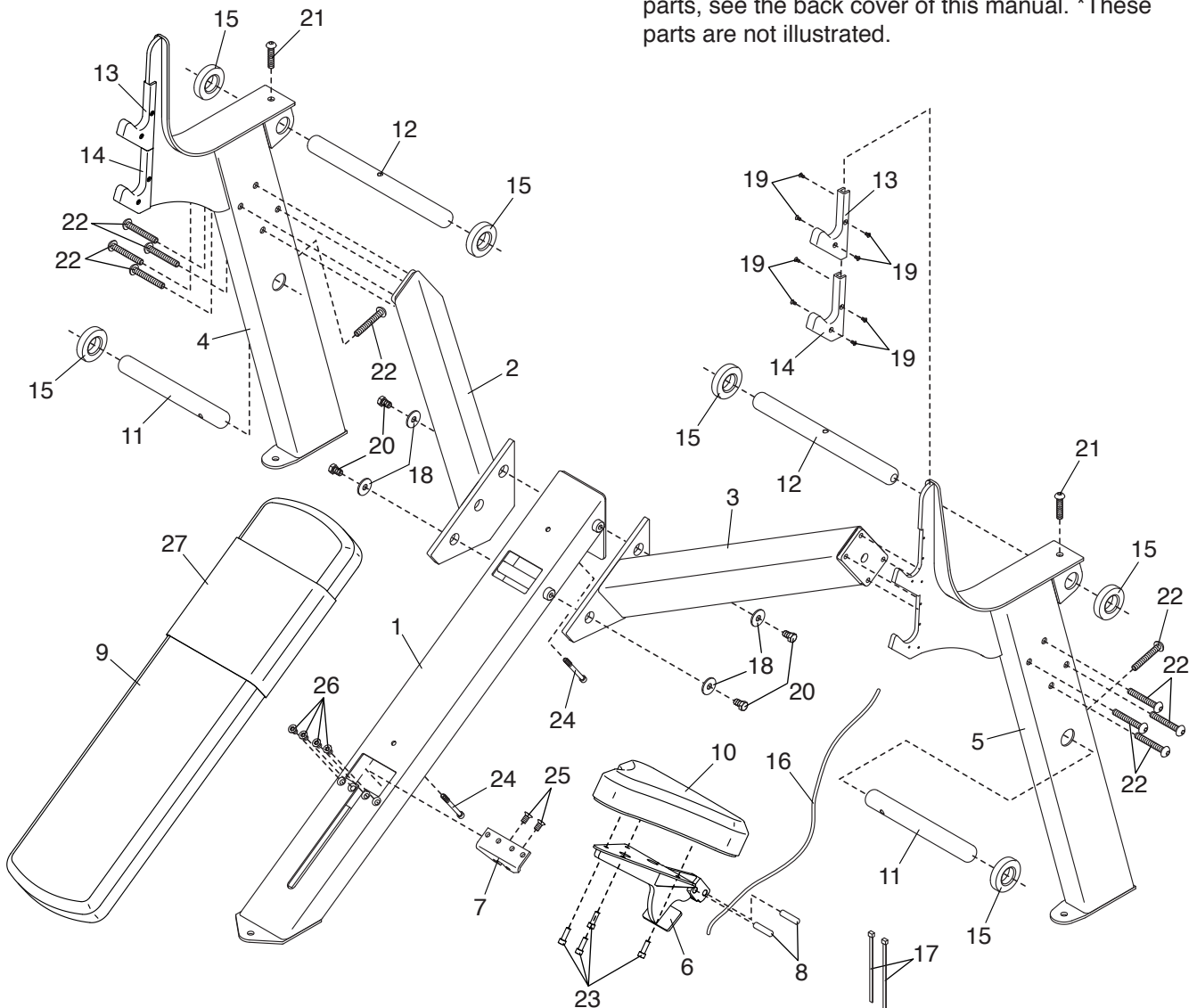

HOW TO CONTACT CUSTOMER CARE

If you have questions after reading this manual, or if parts are damaged or missing, please contact Customer Care at one of the phone numbers or addresses listed below. **Please note the model number, serial number, and name of the product (see the front cover of this manual) before contacting Customer Care. If you are ordering replacement parts, please also note the key number and description of each part (see the PART LIST and the EXPLODED DRAWING near the end of this manual).**

In the United States

Call: 1-800-201-2109, Mon.–Fri. 6 a.m.–6 p.m. MT

Email: customercare@freemotionfitness.com

Write:

Freemotion Fitness
1500 South 1000 West
Logan, UT 84321-9813
United States

Outside the United States

Call: 001-800-527-5417 or 001-435-786-3521,

Mon.–Fri. 6 a.m.–3 p.m. USA Mountain Time

Email: intlcustomercare@freemotionfitness.com

LIMITED WARRANTY

WARRANTY PERIODS AND COVERAGE

Freemotion Fitness warrants this product to be free from defects in workmanship and material under normal use and service conditions. Parts and labor are warranted for one (1) year, unless otherwise specified on the invoice.

The warranty period commences on the invoice date of purchase. Any parts repaired or replaced during this warranty period will be warranted for the remainder of the original warranty period.

CONDITIONS AND LIMITATIONS

The following will void the warranty on this product:

1. This warranty applies only to the original owner and is non-transferable.
2. The labor warranty applies only to products sold in the US and Canada. Contact your authorized Freemotion Fitness dealer for details on labor coverage in your country.
3. Any misuse, abuse, or improper service.
4. Users who weight more than the maximum user weight listed in this manual. Note: This product may not have a maximum user weight.
5. Damage caused by moving the product or improper storage including moving or storing the product on its side.
6. Use or storage of the product outdoors or in high-humidity environments including spa and pool areas.
7. Damage caused by improper wiring or insufficient electrical current. Note: This product may not have wiring.

This warranty shall not apply to the following:

1. Cosmetic items including grips, decals, and labels.

2. Pick-up and delivery or freight charges involved with a repair.
3. Any problem as a result of improper assembly or delivery.

WHAT TO DO IF SERVICE IS REQUIRED

Freemotion Fitness warranty service may be obtained by contacting the authorized dealer from which you purchased this product. Make sure to retain your original invoice and serial number information. If this product experiences a failure under the warranty terms set forth, Freemotion Fitness shall provide at their option either repair, replacement, or refund of the purchase price. Freemotion Fitness compensates service providers for warranty trips within their service area. You may be charged additionally for service calls beyond this service area.

Freemotion Fitness is not responsible or liable for indirect, special, or consequential damages arising out of or in connection with the use or performance of the product; damages with respect to any economic loss, loss of property, loss of revenues or profits, loss of enjoyment or use, or cost of removal or installation; or other consequential damages. Some regions do not allow the exclusion or limitation of consequential damages. Accordingly, the above limitation may not apply to you. This warranty gives you specific rights, and you may have other rights that vary from region to region.

TO CONTACT FREEMOTION FITNESS

See HOW TO CONTACT CUSTOMER CARE above.