

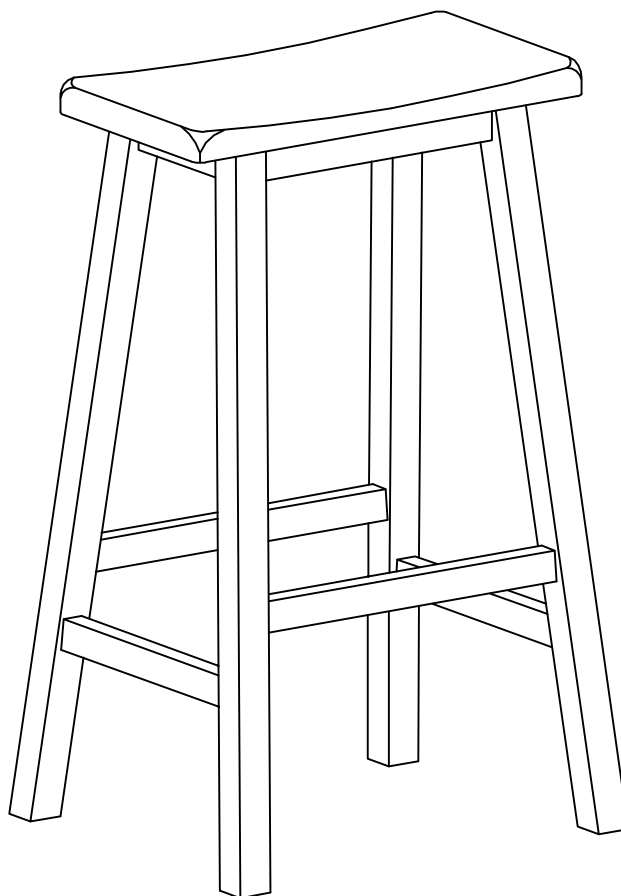

# LINON HOME DECOR PRODUCTS, INC.

---

## ASSEMBLY INSTRUCTIONS SADDLE BAR STOOL



### **WE ARE HERE TO HELP!**

WE DO OUR BEST TO INSURE THAT YOUR FURNITURE ARRIVES IN EXCELLENT CONDITION IN THE EVENT THAT A PART IS DAMAGED OR MISSING, WE WILL BE HAPPY TO PROVIDE YOU WITH REPLACEMENT PARTS, AT NO CHARGE, WITHIN 30 DAYS OF PURCHASE, PROVIDING THE PARTS ARE AVAILABLE IN OUR WAREHOUSE AND THE ITEM PURCHASED IS PART OF OUR CURRENT INVENTORY. IN ORDER TO RECEIVE SPARE PARTS, AT NO CHARGE, YOU MUST PROVIDE PROOF OF PURCHASE WITHIN 30 DAYS.

IF YOU NEED ASSISTANCE WITH ASSEMBLY OR REPLACEMENT PARTS, PLEASE CALL CUSTOMER SERVICE, PRIOR TO RETURNING THE ITEM TO THE STORE.

OUR OFFICE IS OPEN MONDAY - FRIDAY 9AM - 5PM, EASTERN STANDARD TIME.

OUR TOLL FREE CUSTOMER SERVICE NUMBER IS: 1-800-262-1852.

OR VISIT OUR WEB SITE [WWW.LINON.COM](http://WWW.LINON.COM) TO ORDER REPLACEMENT PARTS AND FOR CARE INSTRUCTIONS ON YOUR NEWLY PURCHASED FURNITURE.

IMPORTANT:  
PLEASE READ ALL INSTRUCTIONS IN THIS BOOKLET BEFORE STARTING ASSEMBLY.

MADE IN VIETNAM BY V38







# LINON HOME DECOR PRODUCTS, INC.

## HARDWARE PACKAGE COUNT

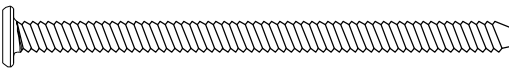
OPEN HARDWARE PACKAGE ON A FLAT SURFACE COVERED WITH NEWSPAPER. COUNT EACH PIECE OF HARDWARE TO MATCH THE QUALITY NUMBER IN THE HARDWARE LIST COLUMN CALL CUSTOMER SERVICE IF ANY OF THE PARTS ARE MISSING. FOLLOW THE LETTER IDENTIFICATION WHEN READING THE ASSEMBLY DRAWING "A" THROUGH " E"

### HARDWARE IDENTIFICATION

SYMBOL	GRAPHICS	DESCRIPTION	QTY
A	  Ø1/4"xL.2-1/8"	LONG BOLT	4
B		SPRING WASHER	4
C		FLAT WASHER	4
D		ALLEN WRENCH	1
E	 Ø4xL.45mm	ROUND HEAD SCREW	8

ALL PARTS ARE LABELED WITH STICKERS MATCHING THE PART IDENTIFICATION NUMBERS LISTED ON PAGE 3.

IF ANY PARTS ARE MISSING OR DAMAGED IN THIS PACKAGE, WE WILL BE HAPPY TO PROVIDE YOU WITH REPLACEMENT PARTS, AT NO CHARGE, WITHIN 30 DAYS OF PURCHASE, PROVIDING THE PARTS ARE AVAILABLE IN OUR WAREHOUSE AND THE ITEM PURCHASED IS PART OF OUR CURRENT INVENTORY. IN ORDER TO RECEIVE SPARE PARTS, AT NO CHARGE, YOU MUST PROVIDE PROOF OF PURCHASE WITHIN 30 DAYS.

CALL US TOLL FREE AT 1-800-262-1852. OR VISIT OUR WEB SITE [WWW.LINON.COM](http://WWW.LINON.COM) TO ORDER PLACEMENT PARTS AND FOR CARE INSTRUCTIONS ON YOUR NEWLY PURCHASED FURNITURE.

#### IMPORTANT

PLEASE USE ALL THE HARDWARE MENTIONED ABOVE  
THEY WILL ASSURE THE ITEM STABILITY AND SAFETY.

#### TOOLS REQUIRED

A STANDARD PHILIPS HEAD SCREWDRIVER ( NOT PROVIDED) AND AN ALLEN WRENCH "D" (PROVIDED) ARE REQUIRED TO ASSEMBLE THIS UNIT. USE A PLASTIC HEAD Mallet, NOT PROVIDED, TO TAP IN STRETCHERS OR OTHER COMPONENTS.



# LINON HOME DECOR PRODUCTS, INC.

## PART IDENTIFICATION:

PART NUMBER	DESCRIPTION	QTY
1	STOOL - SEAT	01
4	FOOT REST	02
5	SIDE STRETCHER	02
6	LEFT SIDE LEG	02
7	RIGHT SIDE LEG	02

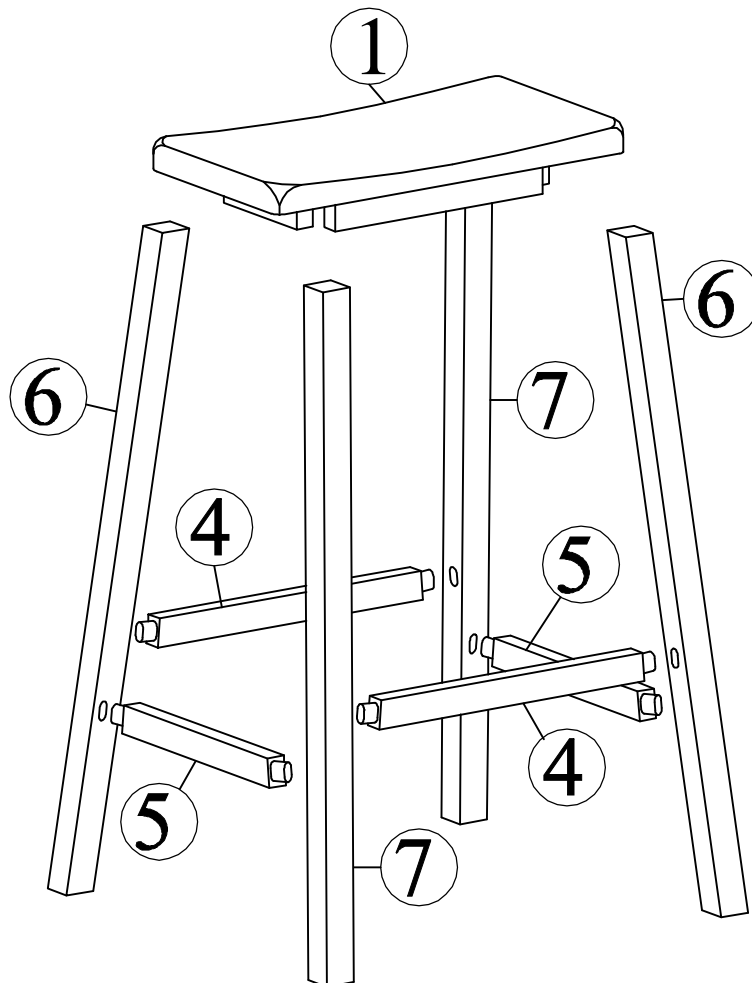



# LINON HOME DECOR PRODUCTS, INC.

STEP 1:

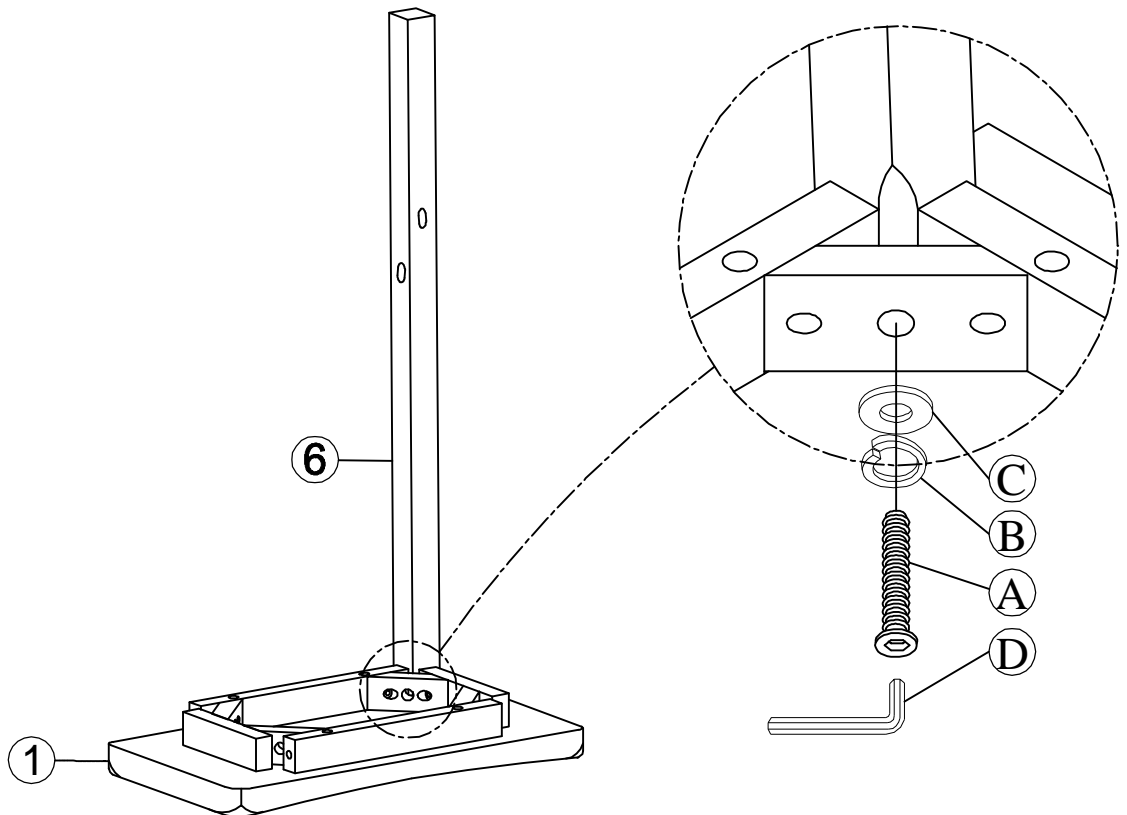

STEP 2:

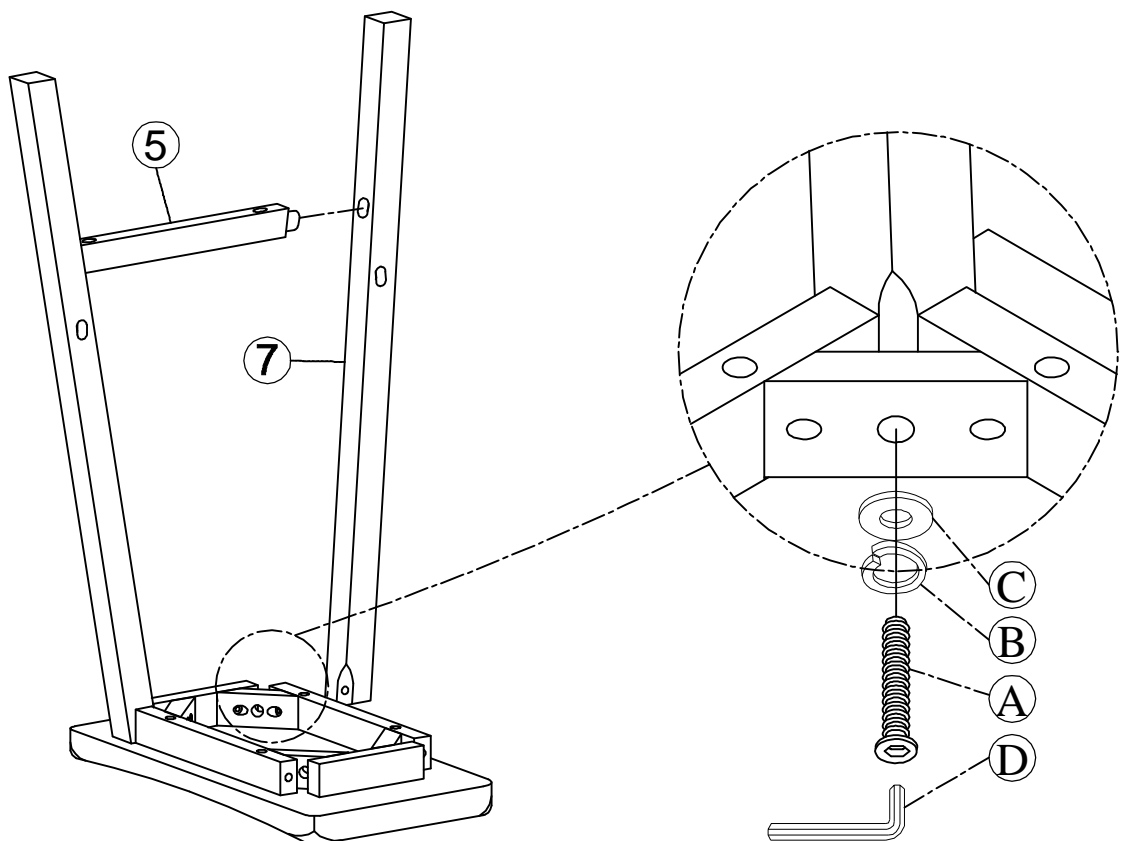



LINON HOME DECOR PRODUCTS, INC.

STEP 1:

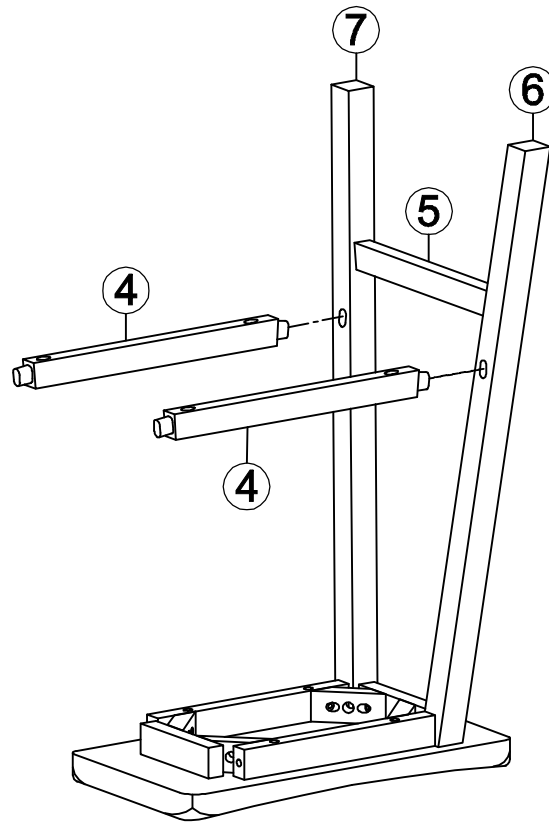

STEP 2:

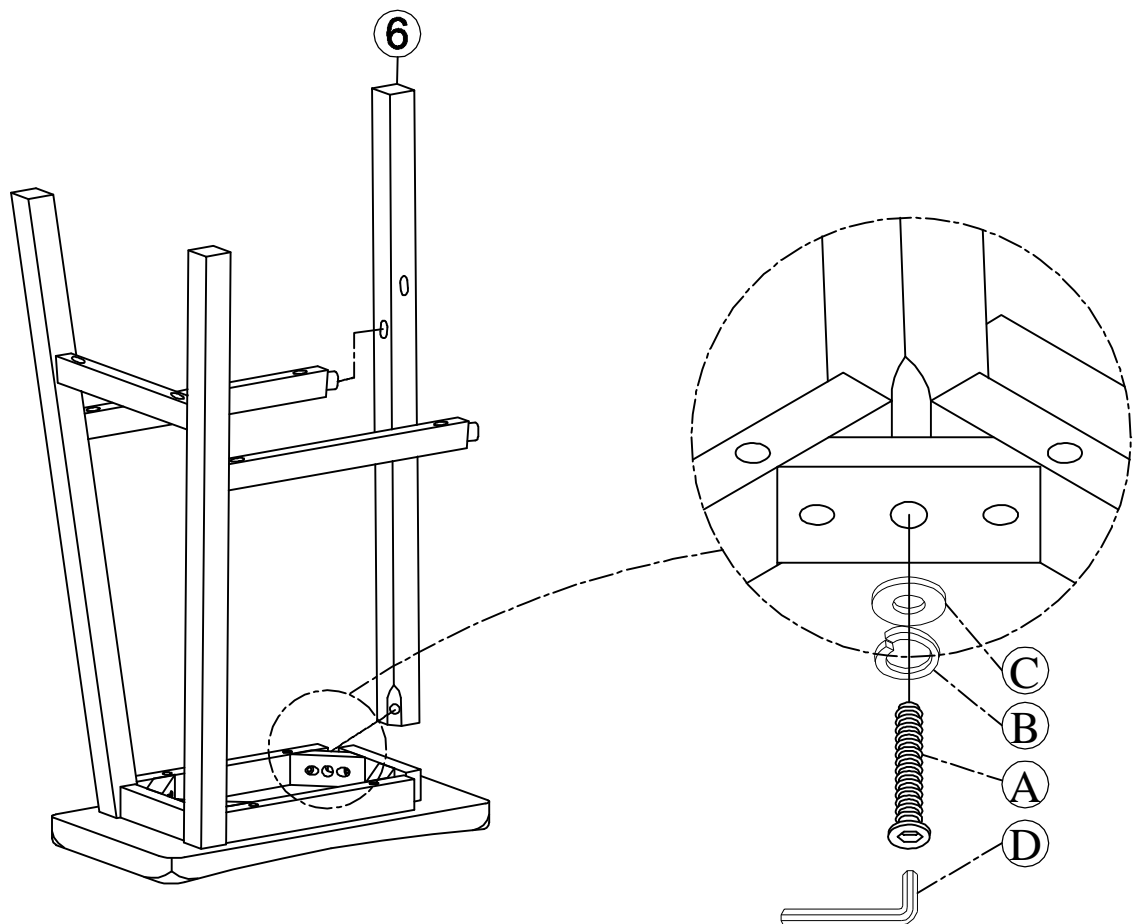



# LINON HOME DECOR PRODUCTS, INC.

STEP 1:

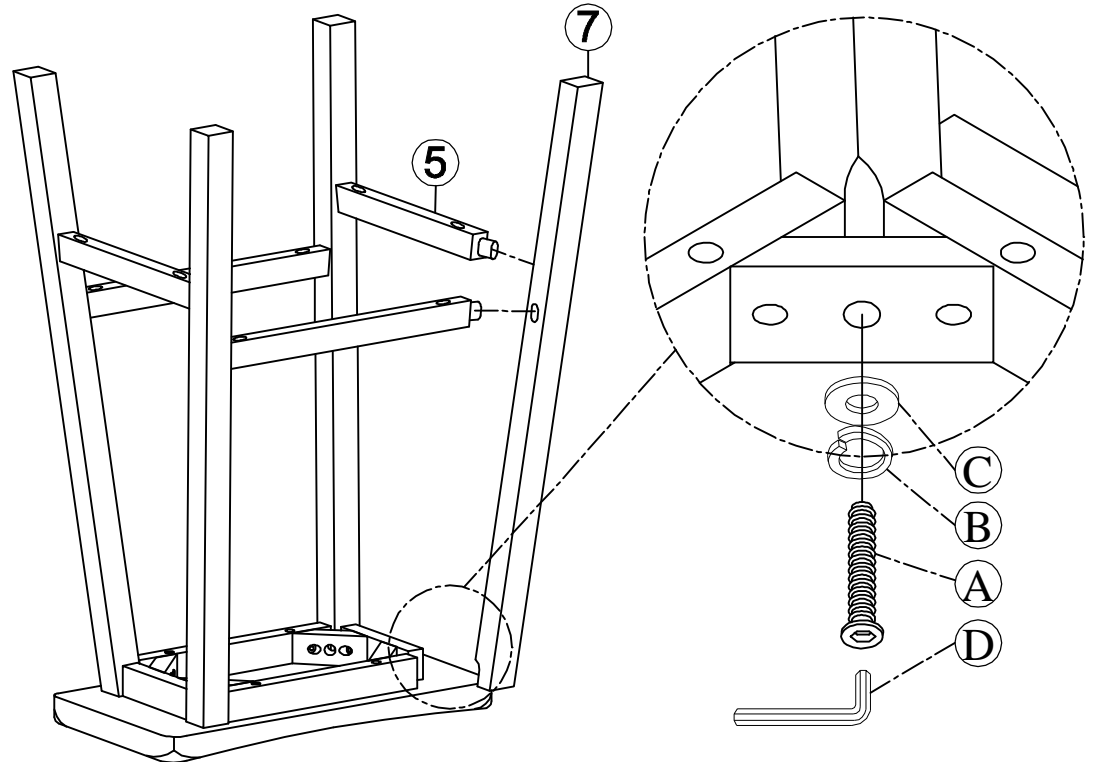

STEP 2:

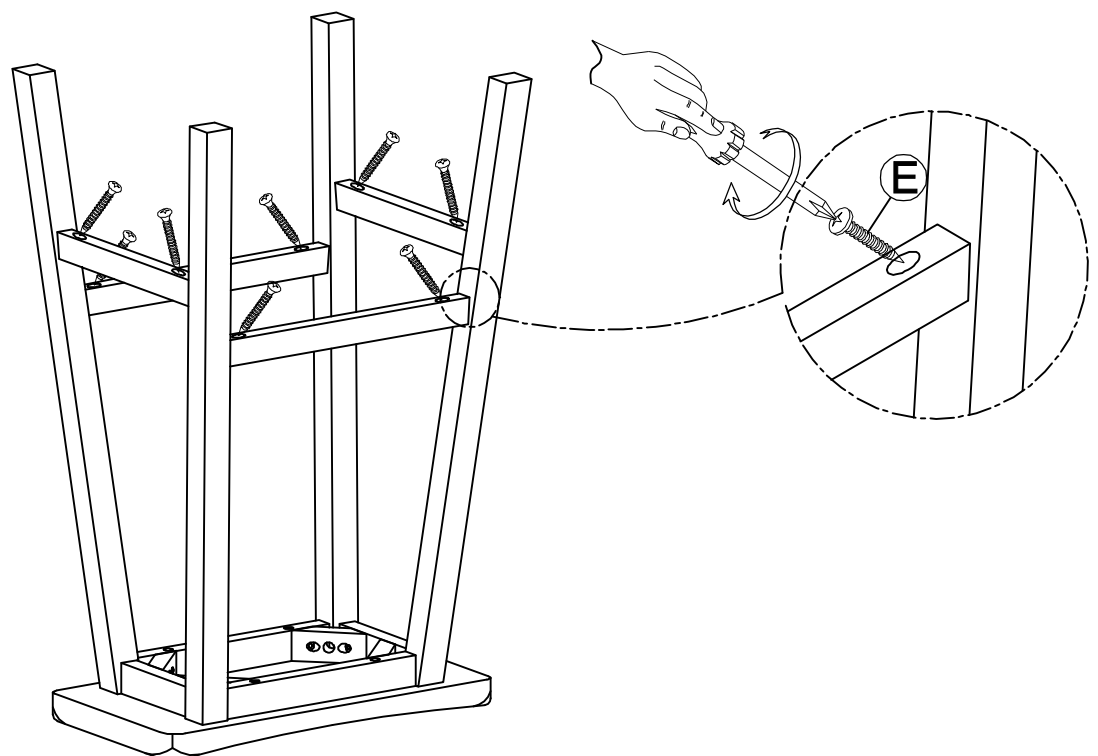



LINON HOME DECOR PRODUCTS, INC.

---

COMPLETED ASSEMBLY

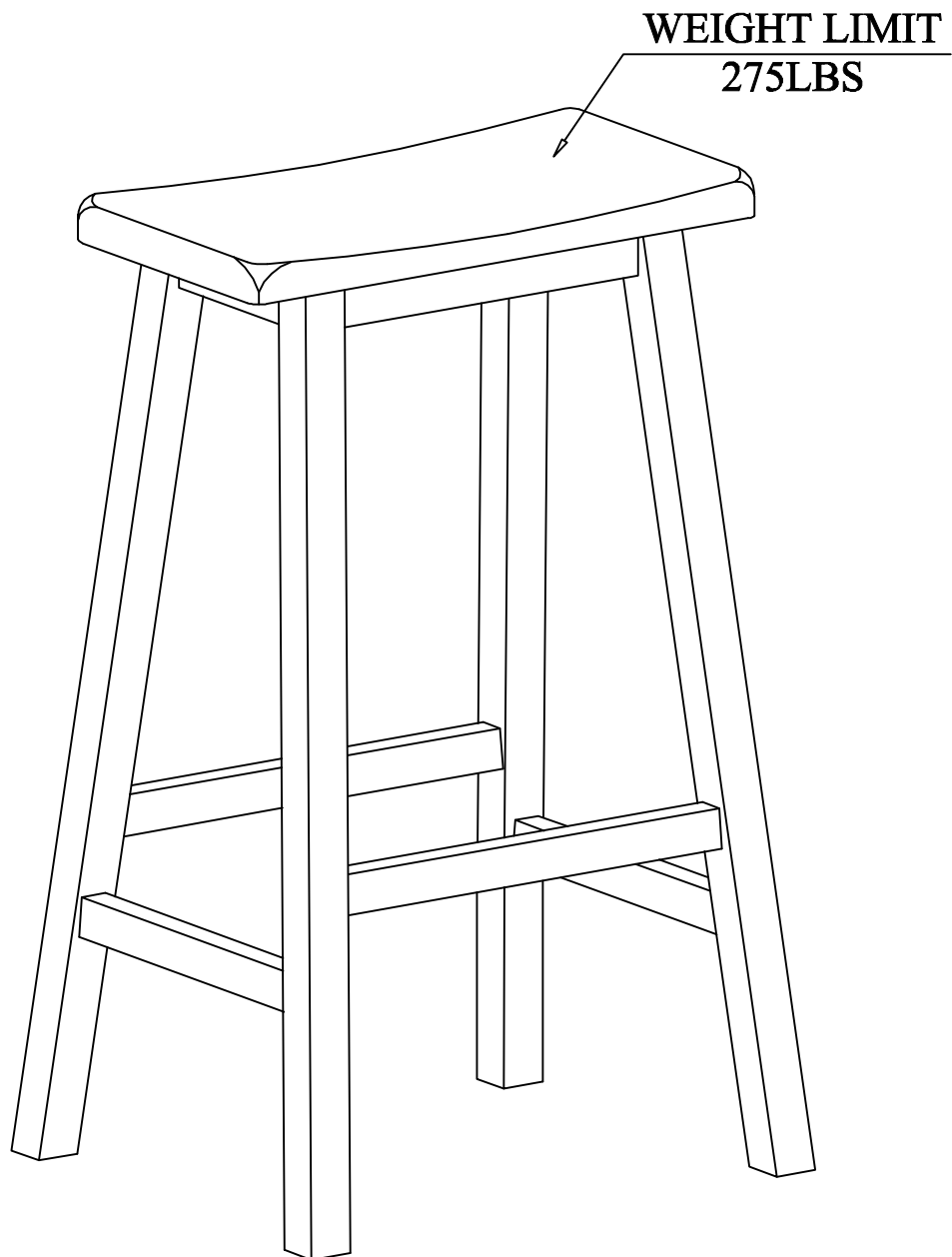



# LINON HOME DECOR PRODUCTS, INC.

---

## LIMITED 6 MONTH WARRANTY

### WHAT IS COVERED

This product is covered under our manufacturer's 6 month limited warranty (Linon Home Décor Products). To ensure your complete satisfaction, this warrants to the original purchaser that the Linon supplied item is free from defects in material and workmanship, as of the date of purchase, and that it will, under normal use and proper care, remain so for six month after the date of purchase.

Replacement of missing or initially defective parts will be sent, at no charge, for a period of 30 days from the date of purchase with valid proof of purchase providing the parts are available in our warehouse and the item purchase is part of our current inventory.

### WHAT IS NOT COVERED

It remains the customer's responsibility for freight and packaging charges to and from the customer service center. Labor and material charges to remove or replace parts under this warranty are not covered

This warranty does not cover: Furniture used for commercial purposes, failures caused by improper care, unreasonable or abusive use, freeze damage, acts of God, rust, purchased parts or return freight and packaging charges. Proof of purchase (dates register receipt) is required for warranty claims.

## HOW TO OBTAIN SERVICE

For further information, please contact our customer service department, c/o Linon Home Décor Products, Inc., between 9:00AM and 5:00 PM Eastern Standard Time, Monday through Friday:

## **LINON HOME DÉCOR PRODUCTS, INC. CUSTOMER SERVICE DEPARTMENT**

Email address: [consumersupport@linon.com](mailto:consumersupport@linon.com)

Toll free number: 1-800-262-1852 Customer service

Visit our web site [www.Linon.com](http://www.Linon.com) to order replacement parts and for care instructions on your newly purchased furniture.