

INSTRUCTION MANUAL

STAND MIXER

MANUEL D'UTILISATION

BATTEUR SUR SOCLE

MANUAL DE INSTRUCCIONES

BATIDORA DE PIE

EN

FR

ES



Important information for the user
Informations importantes pour l'utilisateur
Información importante para el usuario



Instructions / Instructions / Instrucciones



Description / Description / Descripción



Use / Usage / Uso



Cleaning and maintenance / Nettoyage et entretien / Limpieza y mantenimiento



Safety instructions / Directives de sécurité / Instrucciones de seguridad



Information / Informations / Información



Advice / Conseil / Recomendaciones



Scan the QR code for quick access to the My Smeg Assistant portal
Scannez le code QR pour un accès rapide au portail My SMEG Assistant
Escanee el código QR para acceder rápidamente al portal My Smeg Assistant

Dear Customer, Thank you for purchasing one of our appliances. Our products are unique because they combine iconic style with innovative technical solutions. They match perfectly with other products in our range and work equally well as a standalone design objects in your kitchen. We hope you enjoy using your new appliance!

Cher client, merci beaucoup pour votre achat. Nos produits sont uniques car ils combinent une forte recherche esthétique avec une conception technique innovante. Ils sont coordonnés avec d'autres produits de la gamme et peuvent constituer des éléments de design pour votre cuisine. Nous espérons que vous aimerez utiliser votre nouvel appareil !

Estimado Cliente, Le agradecemos por haber comprado uno de nuestros aparatos. Nuestros productos son únicos porque combinan un estilo icónico con soluciones técnicas innovadoras. Combinan perfectamente con otros productos de nuestra gama y trabajan igual de bien como objetos independientes en su cocina. Le deseamos que pueda aprovechar plenamente su nuevo electrodoméstico.

SMEG S.p.A.

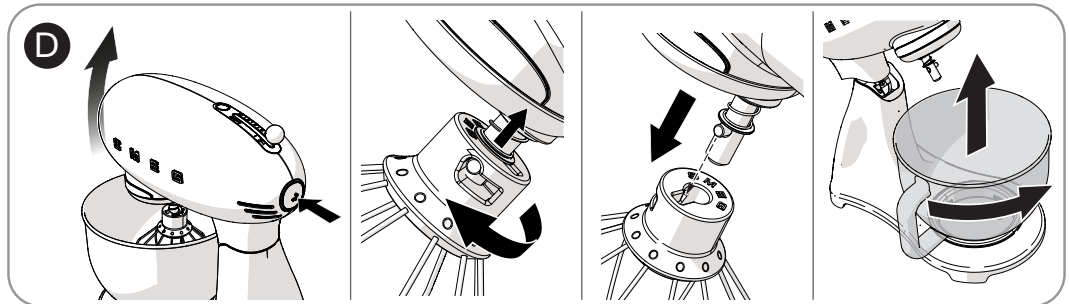
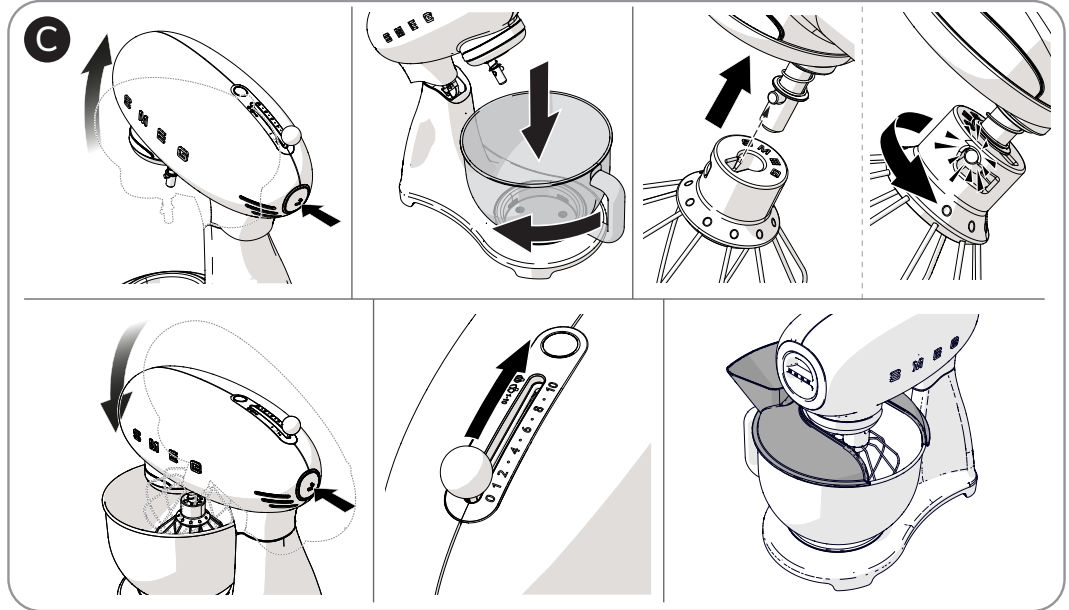
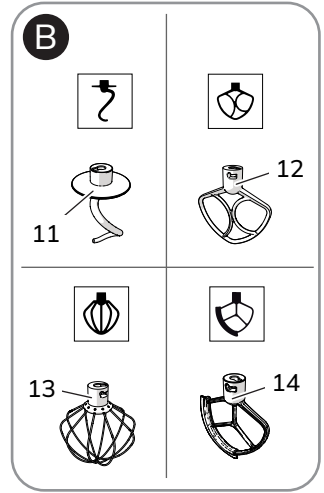
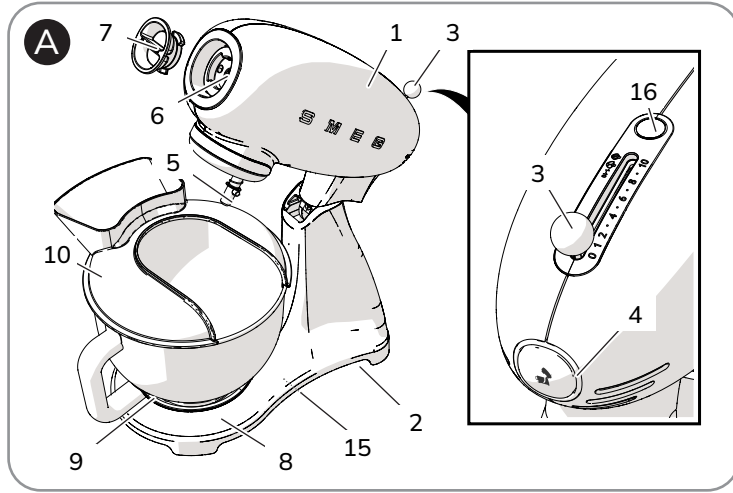

IMPORTANT SAFEGUARDS



WARNING: If the instructions contained in this manual are not followed precisely, a fire or explosion may result causing property damage, personal injury or death.



READ AND SAVE THESE INSTRUCTIONS

Your safety and the safety of others are very important. We have provided many important safety messages throughout this manual and on the appliance. Read all the instructions before using the appliance and always obey all safety messages.



RECOGNIZE SAFETY INFORMATION

This is the safety alert symbol. This symbol alerts you to potential hazards that can result in severe personal injury or death.

UNDERSTAND SIGNAL WORDS

A signal word – DANGER, WARNING, or CAUTION – is used with the safety alert symbol. DANGER denotes the most serious hazards. It means you could be killed or seriously injured if you do not immediately follow the instructions. WARNING means you could be killed or seriously injured if the instructions are not followed. CAUTION indicates a potentially hazardous situation, which, if not avoided, could result in minor to moderate injury.

WARNING



- This appliance is intended for household use only.
- Use this appliance only for its intended purpose. The manufacturer cannot be held liable for damage caused by improper use of this appliance.
- This appliance complies with current safety regulations. Improper use can result in personal injury and material damage.
- Read all the instructions before installing or using the appliance for the first time.
- Keep these operating instructions in a safe place and pass them on to any future user.
- Do not use the appliance for other than intended use.



IMPORTANT SAFEGUARDS

The safety messages will inform you of potential hazards, on how to avoid the risk of injury and what can occur if the instructions are not followed.

IMPORTANT: Observe all codes and ordinances in force.

WARNING: For your safety, the instructions contained in this manual must be followed to minimize the risk of fire or explosion and to prevent property damage, personal injury or death.

Do not store or use gasoline or other flammable vapors, liquids or materials near this or any other appliance.



NOTE: This appliance is NOT designed for installation in manufactured (mobile) homes or in recreational vehicles (RVs).

DO NOT install this appliance outdoors.

IMPORTANT SAFEGUARDS



WARNING



To reduce the risk of fire, electrical shock, personal injury, or damage when using the appliance, follow basic safety precautions, including the following:

EN

1 Safety

1.1 Essential safety information

Follow all safety instructions in order to use the appliance safely:

- Do not touch the plug with wet hands.
- Make sure that the socket is always accessible so that the plug can be removed whenever necessary.
- Do not immerse the appliance, the power cord or the plug in water or any other liquid.
- Do not use the appliance when the power cord or the plug is damaged or after the appliance has been dropped or is damaged in any way.
- The cord is short to prevent accidents. Do not use an extension cord.
- Do not pull on the cord to unplug it from the power socket.
- Ensure the cord does not come into contact with sharp edges.
- Portable - Do not let cord hang over edge of table or counter.
- This appliance is fitted with a ground connection for functional purposes only.
- If the appliance is faulty, do not attempt to repair it. Switch off the appliance, remove the plug from the power socket and contact Technical Support.
- If the plug or power cord becomes damaged, have it replaced only by the Technical Support service in order to avoid risks.
- Keep the packaging material (viscose bags) out of the reach of children.
- Do not modify the appliance.
- Never try to put out a fire or flames with water: turn off the appliance, remove the plug from the power socket and smother the flames with a fire blanket or another appropriate cover.
- Do not leave the appliance unattended while it is in operation.
- Do not attempt to defeat any safety interlock mechanisms.



IMPORTANT SAFEGUARDS

- Make sure that the bowl is correctly positioned and locked onto its base before starting to use the appliance with its standard accessories.
- Do not release or remove the bowl while the appliance is in operation.
- Do not insert, remove or replace the standard accessories with the safety lock disengaged (motor head lowered).
- Do not remove accessories while the appliance is in operation.
- Do not touch moving parts while the appliance is in operation. Keep hands, hair, clothing, spatulas and any other objects away from the mixer's standard and optional accessories to avoid personal injury or damage to the machine.
- Do not exceed maximum capacity of the bowl.
- Only use original standard and optional accessories provided by the manufacturer. The use of non-original components, standard and optional accessories could lead to personal injury or damage to the appliance.
- Do not place anything on top of the appliance.
- Do not place the appliance above or near lit hob burners or electric rings, inside an oven or near to other heat sources.
- Make sure there are no foreign objects inside the appliance.
- Immerse the whisks into the bowl containing the ingredients before starting the appliance.
- This manual contains instructions for cleaning, maintenance and recommendations from the manufacturer to the customer. Any other interventions should be carried out by an authorized service center.
- Instructions for cleaning of the appliance can be found in the "4 Cleaning and maintenance" section.
- Remove beaters from mixer before washing.
- This appliance may not be used by people (including children) with reduced physical or mental capabilities or without sufficient experience and knowledge unless they are supervised or instructed on how to use the appliance by a person who is responsible for their safety.
- Children must be supervised at all times to make sure they do not play with the appliance.



1.2 Connecting the appliance

Make sure that the voltage and frequency of the power supply correspond to those indicated on the data plate on the bottom of the appliance.

If the plug of the appliance is not compatible with the socket, contact Technical Assistance service for replacement.

- Children must never be allowed to play with this appliance.
- Keep the appliance out of the reach of children.
- Always unplug the appliance from the power socket if it is to be left unattended and before assembly, disassembly or cleaning.
- Switch off the appliance and unplug it from the power supply before changing the accessories or when close to moving parts when in use.
- Portable - Turn the appliance OFF, then unplug from the outlet when not in use, before assembling or disassembling parts and before cleaning. To unplug, grasp the plug and pull from the outlet. Never pull from the power cord. Permanently installed - Make sure appliance is OFF when not in use, before putting on or taking off parts, and before cleaning.
- The use of attachments not recommended or sold by the manufacturer may cause fire, electric shock or injury.

1.3 Intended use

Failure to comply with the safety instructions and failure to read the instruction manual for the food processors can lead to the appliance being used incorrectly and cause personal injury.

- Do not use the appliance for purposes other than those for which it was designed. The mixer is intended exclusively to mix, whip, whisk and knead solid and liquid ingredients to make various preparations. With the addition of optional accessories, it is able to roll out and cut pasta into different shapes.
- The appliance is not designed to operate with external timers or with remote-control systems.
- Use the appliance indoors.
- This appliance is intended for household use and similar applications such as:
 - staff kitchen areas in shops, offices and other working environments
 - bed and breakfast facilities / farm accommodation
 - by guests in hotels, motels and other types of residential accommodation.
- Any other use, for example in restaurants, coffee bars and coffee shops is considered improper.



IMPORTANT SAFEGUARDS

1.4 Manufacturer's liability

The manufacturer declines any liability for personal injury or damage to property caused by:

- Use of the appliance other than the intended use
- Not having read the user manual
- Tampering with any part of the appliance
- Use of non-original spare parts
- Failure to comply with the safety instructions



Please keep these instructions carefully. If the appliance is passed on to others, they should also be given this instruction booklet.

These instructions can be downloaded from the Smeg website “www.smeg.com”.

1.5 Disposal

Electrical appliances must not be disposed of together with household waste.



Appliances marked with this symbol are subject to European Directive 2012/19/EU.

- All waste electrical and electronic appliances must be disposed of separately from domestic waste and taken to authorized waste disposal facilities. Disposing of the used appliance correctly will help to safeguard the environment and human health. For further information regarding the disposal of used appliances, please contact your local authority waste disposal department or the shop where the appliance was purchased.

SAVE THESE INSTRUCTIONS



2 Appliance description (Fig. A and B)

- 1) Motor head
- 2) Body
- 3) Speed selector
- 4) Head raising/lowering release button
- 5) Lower attachment for standard accessories
- 6) Front attachment hub for optional accessories
- 7) Front hub cover
- 8) Bowl base
- 9) Bowl**
- 10) Pouring shield*
- 11) Dough hook
- 12) Flat beater
- 13) Wire whisk
- 14) Flex edge beater*
- 15) Identification plate

2.1 Identification plate (Fig. A)

The identification plate (15) bears the technical data, serial number and brand name of the appliance. Do not remove the identification plate for any reason.

* Standard only on certain models. Also available as an optional accessory.

** The bowl design and material may be different depending on model of mixer

2.2 Before first use



Caution

Plug into a grounded three-pin socket.

- Do not remove the ground prong.
- Do not use an adapter.
- Do not use an extension cord.
- Failure to follow these instructions could result in death, fire, or electrical shock.

- Unpack the appliance carefully and remove all packaging materials and any labels and stickers.
- Clean the body and head of the appliance with a damp cloth.
- Remove the bowl and standard accessories. Wash and dry them thoroughly (see section “4 Cleaning and maintenance”).



Before use, make sure that all the components are intact.



Description

2.3 Description of accessories (Fig. A and B)

Aluminum dough hook (11)

For slowly combining, mixing and kneading leavened dough-type mixtures, including bread, pasta, pizza etc.

Aluminum flat beater (12)

For combining, mixing, and starting all mixing procedures.

For preparing cake batters and pastries, biscuits, icing, etc. and for other, thicker batters and mixes

Stainless steel wire whisk (13)

For beating, mixing, whisking, whipping ingredients such as butter, egg whites, cream etc.

Also ideal for preparing creams, custards, sauces etc.

Flex edge beater* (14)

Aluminum beater with flexible silicone edges.

Useful for mixing doughs and soft batters. The silicone edge ensures that ingredients are scraped off the sides of the bowl during processing, making them easier to incorporate and ensuring a perfect texture.

Pouring shield* (10)

For protecting against splattering and to facilitate the addition of ingredients when in use. Only suitable for use with the stainless steel bowl*.



The standard and optional accessories intended to come into contact with food are made of materials that comply with the provisions of current legislation.



Caution

The spring lift motor head must always be locked in the horizontal position when lifting and moving the mixer or when inserting optional accessories in the front section.

* Standard only on certain models. Also available as an optional accessory.



3 Use

3.1 Using the mixer (Fig. A, B and C)

- Place the mixer on a flat, stable and dry surface.
- Press the release button (4) and lift the head (1), guiding it with your hand until it is fully locked.
- Insert the bowl (9) in its base (8). Grasp the bowl by its handle and turn the bowl (9) clockwise until it locks into place.
- Select the accessory according to the type of mixing to be performed.



Caution

Do not operate the mixer with the accessory without having locked the bowl in position.

- Insert the accessory into the lower attachment (5) and push it upwards. Keep pressing the accessory upwards and turn it counterclockwise until the pin locks fully into place (5).



Ensure that the accessory is correctly locked into place in the attachment.

- Add the ingredients to the bowl.
- Press the button (4) and lower the head (1), guiding it with your hand until it is fully locked.
- Position the pouring shield* (10) on the bowl, if required, with the opening facing outwards.



Using the pouring shield* (10)

- Fit the pouring shield onto the upper rim of the stainless steel bowl* after having inserted the bowl into its base, inserted the accessory into the lower attachment and after having lowered the head into the operating position.
- Fit the pouring shield with the opening facing outwards so that ingredients can be added to the bowl without having to stop the mixer.



Caution

Remove the pouring shield to raise or lower the head with the accessory fixed to the lower attachment.

- Make sure that the speed selector (3) is in the "0" (OFF) position.
- Insert the plug into the power socket.
- Select the required speed (3) to start the appliance and begin mixing the ingredients. See "3.5 Recommended speeds".

* Standard only on certain models. Also available as an optional accessory.



Use



Caution

- For increased safety, each time power is disconnected to the motor, for example by raising the head or unplugging the appliance from the socket, the speed selector first has to be placed in the zero position before the mixer is restarted.
- You should anyway always move the speed selector to the "0" (OFF) position before pressing the button to move the motor head.



Caution

- Do not touch the accessories while the appliance is in operation.
- Do not operate the mixer with the accessory inserted and the bowl empty.



It is possible for the motor head to move slightly when mixing or kneading dense mixtures or large quantities. This is normal and will not affect the operation, long lifetime or the appliance.

3.2 When finished (Fig. B and D)

- Place the speed selector (3) in the "0" (OFF) position and remove the plug from the power socket.
- Remove the pouring shield (10) from the bowl, if present.
- Press the release button (4) to raise the head (1), guiding it with your hand until it is fully locked.
- Push the accessory slightly upwards and turn it clockwise to release it from the pin. Remove the accessory from the lower attachment (5).
- Remove the bowl (9) from its base by turning it counterclockwise to release it.



3.3 Functions

Safety lock system

The appliance is fitted with a safety system that automatically shuts off the appliance when the motor head is raised.

Smooth Start System

When the appliance is started, the speed is gradually increased until the set speed is reached. This prevents damage to the appliance and accessories and ensures that ingredients are not ejected from the bowl.



Planetary movement

The mixer accessories move with a planetary mixing action.

The movement is generated by the accessory rotating around its axis in the opposite direction to the rotary movement of the mixer.

This maximizes coverage of the entire bowl so that all ingredients are thoroughly blended with excellent results for all preparations.



Hot appliance

Following prolonged use, the upper part of the motor head may become hot. This does not, however, normally indicate a malfunction.

3.4 General advice

- Never exceed the maximum speed and capacity indicated in the table in order to prevent damage to the appliance.
- Turn on the appliance at a low speed until all the ingredients are mixed, then increase the speed according to the required operation.
- When adding ingredients, always pour them onto the edge of the bowl and not directly onto the moving accessory.
- Reduce the speed when you add dry or liquid ingredients to prevent splattering. Increase the speed again when they have been mixed.
- Use the pouring shield* on the bowl for liquid mixtures or when adding dry ingredients to avoid getting objects in the vicinity of the stand mixer dirty or being splashed by liquids or powder.
- Keep the bowl and accessories clean. Attach them to the appliance only when they are perfectly dry.
- Clean the head and body of the mixer carefully using a damp cloth.

* Standard only on certain models. Also available as an optional accessory.



Use

Tips for whisking egg whites

- For the best results, use egg whites at room temperature.
- Before whisking the egg whites, ensure that the accessory and bowl are not damp or greasy and that they have no egg yolk on them.
- To prevent splattering, gradually increase the speed up to the recommended speed, then whisk until you achieve the required stiffness.
- The stand mixer allows egg whites to be whisked very quickly. Pay close attention to the process to avoid over-whisking the egg whites, which would result in separation.

Tips for whipping cream

- For the best results, use cold whipping or double cream straight out of the fridge.
- To prevent splattering, gradually increase the speed up to the recommended speed, then whip until you achieve the required consistency.
- When whipping a liter of liquid cream, it is advisable to gradually increase the speed to 7-8 for the first minute or at least until the cream begins to thicken. Then increase the speed to 10 for the remaining time.

Recommendations for kneading

- Make sure that the proportion of liquids in doughs is sufficient (at least 55-60% of the quantity of flour, by weight). Doughs which are too dry and therefore stiff can overload the motor.
- If the appliance is struggling, switch it off, divide the dough into two parts and knead them separately.

Bread/pizza dough and egg pasta dough

- Start the appliance at speed 1 until the ingredients have been incorporated, then increase to speed 2.
- To mix the ingredients more effectively, it is recommended to add the liquid ingredients to the bowl first and then gradually add the solid ingredients.
- Egg pasta, bread, pizza: only knead using the dough hook. DO NOT use the flex edge beater*.

Prepared cake batters

- For up to 2.2 lb batter: start the appliance at a low speed until the ingredients start to come together, then gradually increase the speed up to 7 for the remaining time.
- For up to 4.4 lb of batter: start the appliance at speed 1 until the ingredients start to come together, then gradually increase the speed up to 3-4 for the remaining time.

Pastry

- Cold ingredients should always be used when making pastry, particularly short pastes, unless the recipe states otherwise.
- When preparing cakes, initially beat the butter at room temperature with sugar, then add the eggs and lastly the flour.

* Standard only on certain models. Also available as an optional accessory.



3.5 Recommended speeds



The speed selector (3) indicates the most appropriate accessory to use with the selected speed. The speeds indicated in the table are approximate and can vary depending on the recipe and the interaction of the different ingredients used.

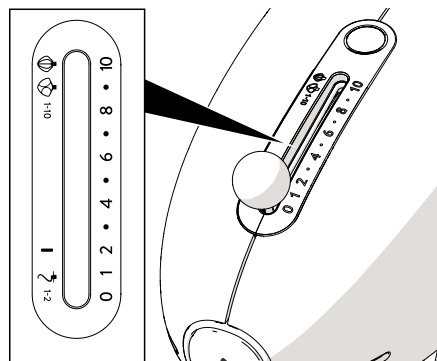





Speed setting	Function	Accessory
LOW 1 - 2	COMBINING AND KNEADING Kneading - preparing leavened doughs (bread, pizza, egg pasta etc.), see "Bread/pizza dough and egg pasta dough".	
LOW 1 - 3	COMBINING Combining ingredients.	
MEDIUM 4 - 7	MIXING Mixing and beating dense batters. Beating eggs and butter, cake mixes such as fruitcake.	
HIGH 8 - 10	WHIPPING AND WHISKING Whisking light or dense batters. Whipping cream, egg whites or sauces.	

* Standard only on certain models. Also available as an optional accessory.



Use

Accessories and recommended speeds, maximum capacity for model SMF04

Accessory	Preparation	Speed	Time	Min/max capacity
	Egg whites	8-10	2-3 min	2 - 12 ⁽¹⁾
	Cream	8-10	2-3 min	3.4 fl oz/33.8 fl oz
 or 	Prepared cake batters	1-7	3-4 min	4.4 lb total batter (max. 2.2 lb flour)
	Pastry	1-7	3-4 min	5.7 lb total batter (max. 2.2 lb flour)
	Bread/ pizza dough	1-2	4 min	4.2 lb total dough (max. 2.6 lb flour/ min. 55% hydration)
	Egg pasta dough	1-2	5-7 min	1.1 lb total batter (max. 0.7 lb flour/ min. 55% hydration)

(1) Average egg size: 1.9-2.2 oz

* Standard only on certain models. Also available as an optional accessory.







The table should be considered a guideline only.
The speed and capacity depend on the accessory used, the quantity of mixture in the bowl and the ingredients used.

Use



Accessories and recommended speeds, maximum capacity for model SMF05/SMF15

Accessory	Preparation	Speed	Time	Min/max capacity
	Egg whites	8-10	2-3 min	2 - 12 ⁽¹⁾
	Cream	8-10	2-3 min	3.4 fl oz/33.8 fl oz
 or 	Prepared cake batters	1-7	3-4 min	4.4 lb total batter (max. 2.2 lb flour)
	Pastry	1-7	3-4 min	6.2 lb total batter (max. 2.2 lb flour)
	Bread/ pizza dough	1-2	4 min	4.6 lb total dough (max. 2.9 lb flour/ min. 55% hydration)
	Egg pasta dough	1-2	5-7 min	1.8 lb total batter (max. 1.1 lb flour/ min. 55% hydration)

(1) Average egg size: 1.9-2.2 oz



The table should be considered a guideline only. The speed and capacity depend on the accessory used, the quantity of mixture in the bowl and the ingredients used.



Cleaning and maintenance

4 Cleaning and maintenance

This manual contains instructions for cleaning, maintenance and recommendations from the manufacturer to the customer. Any other interventions should be carried out by an authorized service center.

Before cleaning, ALWAYS remove the plug from the power supply and allow the appliance to cool down. Never immerse the motor base (2) in water or other liquids.



Splattered liquids or batters should be removed immediately using a soft, damp, cotton cloth.



Caution

- Do not use steam jets to clean the appliance.
- Do not use cleaning products containing chlorine, ammonia, bleach or alcohol on steel parts or parts with a metallic finish.
- Do not use harsh or abrasive detergents (e.g. powder products or stain removers).
- Do not use rough or abrasive materials or sharp metal scrapers.
- Regularly clean the components and accessories after each use.

- The dough hook, flat beater, flex edge beater*, the pouring shield* and stainless steel bowl* are dishwasher safe.
- The wire whisk can be hand washed with a neutral detergent and a soft sponge.
- The glass bowl* can be washed by hand with warm water and a neutral detergent or in a dishwasher using a low temperature (maximum 50° C) program.
- The ring nut at the base of the bowl can be removed and washed separately by hand using a neutral detergent and a soft sponge.

* Standard only on certain models. Also available as an optional accessory.

What to do if...

Problem	Cause	Solution
The motor does not start.	The motor has overheated.	Disconnect the mixer from the power supply and allow the motor cool down.
	The plug is not properly inserted in the power socket.	Insert the plug into the power socket. Do not use adapters or extensions. Check that the house main breaker is on.
	The power cord is defective.	Have the power cord replaced at an Authorized Service Center.
	No power.	Check that the house main breaker is on.
	The head has been raised during operation.	The safety lock system has activated. Move the speed selector to "0" (OFF), press and hold down the button on the rear to release the head and lower it.
The appliance vibrates.	The mixer is not resting on a stable surface.	Place the mixer on a flat, stable surface.
	The anti-slip rubber feet are worn.	Have them replaced at an Authorized Service Center.
	The speed has been set too high or the load is excessive.	Set a lower speed and make sure the bowl has not been overfilled.
	The bowl has not been correctly locked into its base.	Check that the bowl is correctly locked into its base.

What to do if...

Problem	Cause	Solution
The accessories hit the sides of the bowl.	The lower attachment has come loose over time.	Have the mixer checked and adjusted at an Authorized Service Center.
	The accessory or the bowl is not correctly locked into position.	Move the speed selector to "0", press the button on the rear of the appliance to raise the head and check that the accessory is correctly locked into position in the lower attachment and the bowl is correctly locked into position on the base.
The accessory has difficulty rotating inside the bowl.	The dough mixture is too thick and is preventing the accessory from turning.	Add water or another liquid to loosen the dough mixture.
	The bowl is too full.	Remove half the contents of the bowl and work it separately.



If the problem has not been resolved or if there is another type of fault, contact your local technical support center.

For all stand mixer models:

Accessory: Flat Edge Beater.

Ingredients: 1.8 lb flour, 1.2 lb water.

(For certification reference only)

The manufacturer reserves the right to make any changes deemed necessary for the improvement of its products without prior notice. The illustrations and descriptions contained in this manual are therefore not binding and are merely indicative.

Le fabricant se réserve le droit d'apporter, sans préavis, toutes les modifications qu'il jugera utiles pour l'amélioration de ses produits. Les illustrations et les descriptions figurant dans ce manuel ne sont pas contraignantes et n'ont qu'une valeur indicative.

El fabricante se reserva el derecho a aportar sin aviso previo todas las modificaciones que considere necesarias para la mejora de sus propios productos. Las ilustraciones y las descripciones contenidas en este manual no comprometen, por tanto, al fabricante y tienen un valor meramente indicativo.