

USER MANUAL

MULTI-USE GRILL

EN

MANUEL D'UTILISATION

GRILLE-VIANDE MULTIFONCTION

FR

MANUAL DE USO

GRILL MULTIUSOS

ES



Important information for the user
Informations importantes pour l'utilisateur
Información importante para el usuario



Recommendations / Avertissements / Advertencias



Description / Description / Descripción



Use / Utilisation / Uso



Cleaning and care / Nettoyage et entretien / Limpieza y mantenimiento



Safety instructions / Consignes de sécurité / Advertencia de seguridad



Information / Information / Información



Advice / Conseil / Sugerencia

Dear Customer, Thank you for purchasing one of our appliances. Our products are unique because they combine iconic style with innovative technical solutions. They match perfectly with other products in our range and work equally well as a standalone design objects in your kitchen. We hope you enjoy using your new appliance! Best regards.

Cher client, merci beaucoup pour votre achat. Nos produits sont uniques car ils combinent une forte recherche esthétique avec une conception technique innovante. Ils sont coordonnés avec d'autres produits de la gamme et peuvent constituer des éléments d'ameublement et de design. En espérant que vous pourrez apprécier pleinement votre nouvel appareil électroménager, nous vous adressons nos meilleures salutations.

Estimado cliente, le damos las gracias por su compra. Nuestros productos son únicos porque combinan una notable búsqueda estética con un diseño técnico innovador. Se combinan con otros productos de la gama y se pueden utilizar como elementos de decoración y diseño. Le deseamos que pueda apreciar plenamente su nuevo electrodoméstico. Le enviamos nuestros saludos más cordiales.

SMEG S.p.A.

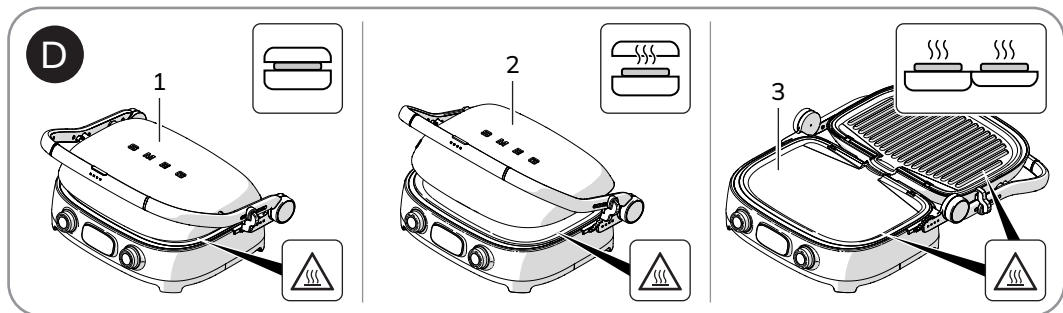
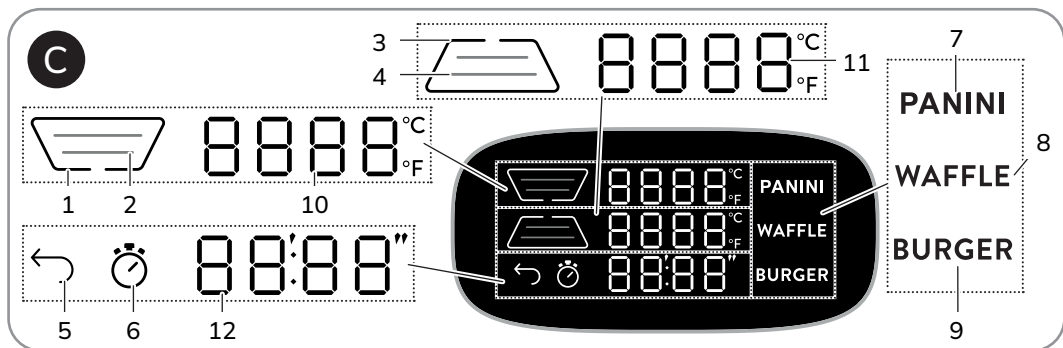
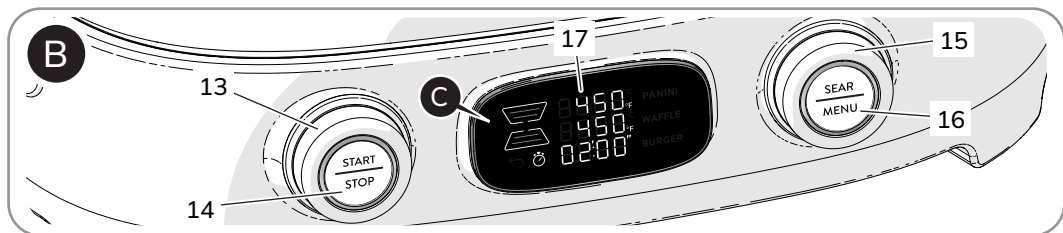
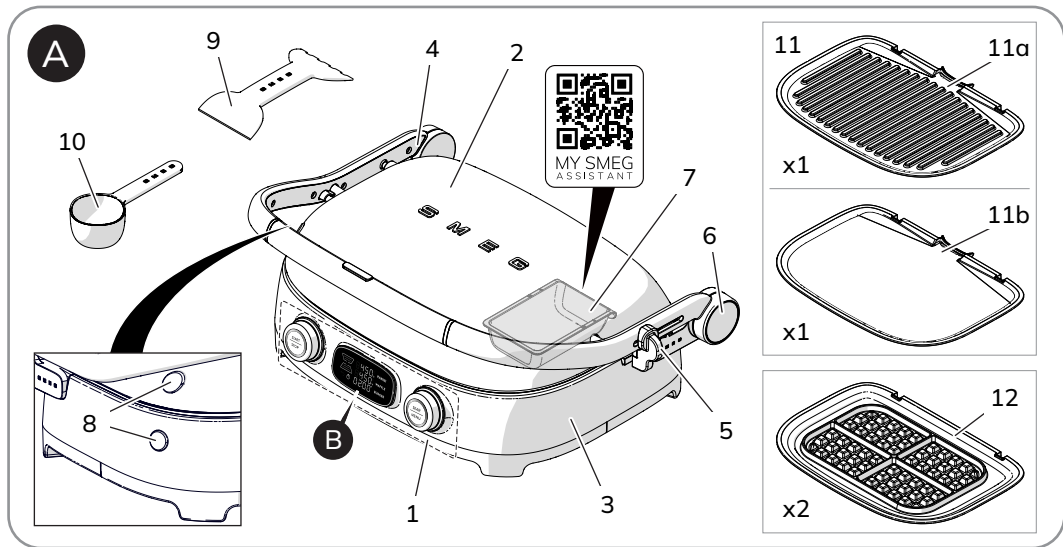

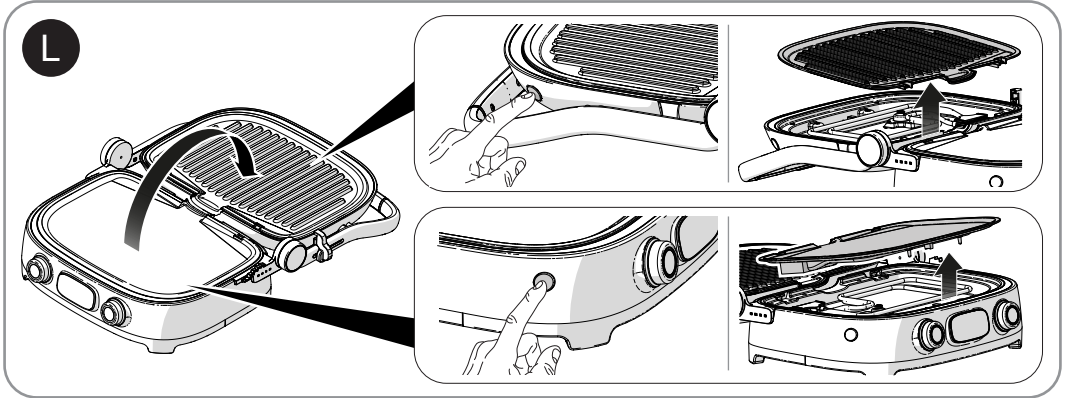
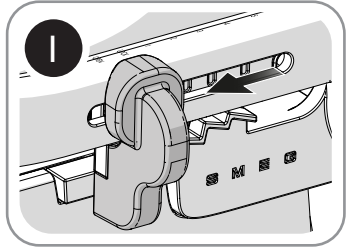
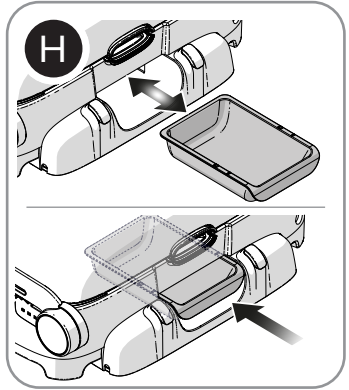
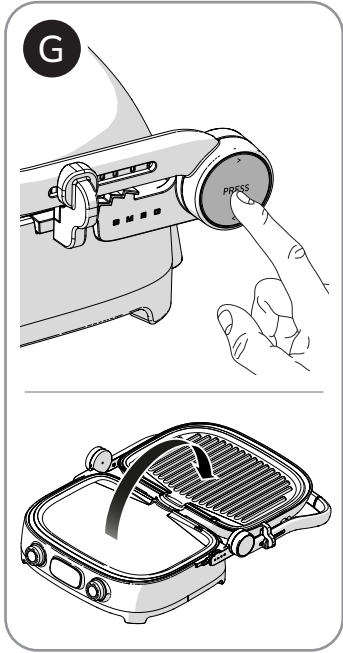
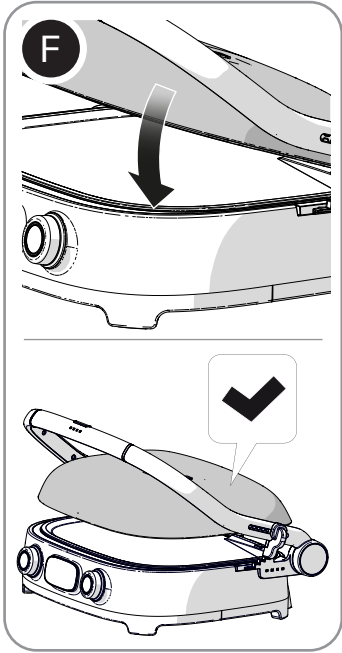
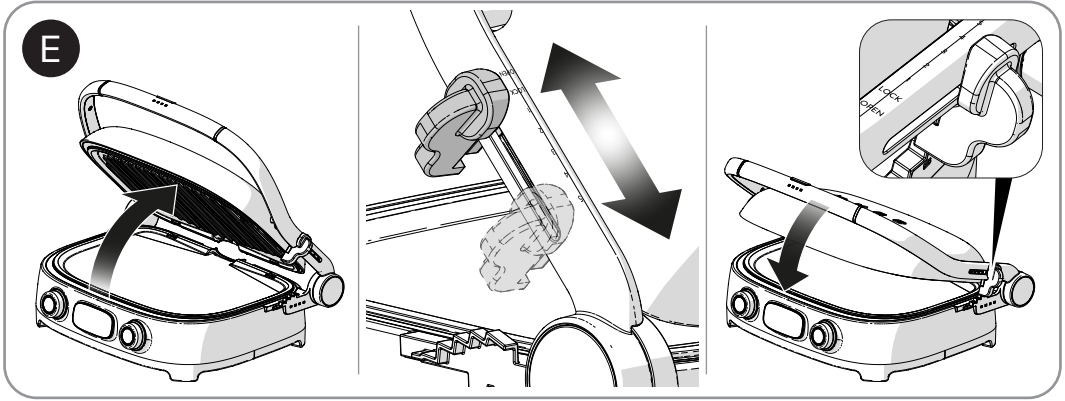

IMPORTANT SAFEGUARDS



EN

WARNING: If the instructions contained in this manual are not followed precisely, a fire or explosion may result causing property damage, personal injury or death.

WARNING



Basic safety precautions should always be followed when using the appliance.

- A short power cord should be provided to minimize the risk of entanglement.
- Extension cords are available if used with care.
- If an extension cord is used, the marked electrical rating of the extension cord should be at least as great as 15A. The extension cord should be a grounding 3-wire cord. The longer cord should be arranged so that it does not drape over the countertop or table top where it can be pulled on by children or tripped over unintentionally.



READ AND SAVE THESE INSTRUCTIONS

Your safety and the safety of others are very important. We have provided many important safety messages throughout this manual and on the appliance. Read all the instructions before using the appliance and always obey all safety messages.



RECOGNIZE SAFETY INFORMATION

This is the safety alert symbol. This symbol alerts you to potential hazards that can result in severe personal injury or death.

UNDERSTAND SIGNAL WORDS

A signal word – DANGER, WARNING, or CAUTION – is used with the safety alert symbol. DANGER denotes the most serious hazards. It means you could be killed or seriously injured if you do not immediately follow the instructions. WARNING means you could be killed or seriously injured if the instructions are not followed. CAUTION indicates a potentially hazardous situation, which, if not avoided, could result in minor to moderate injury.



IMPORTANT SAFEGUARDS

WARNING



- This appliance is intended for household use only.
- Use this appliance only for its intended purpose. The manufacturer cannot be held liable for damage caused by improper use of this appliance.
- This appliance complies with current safety regulations. Improper use can result in personal injury and material damage.
- Read all the instructions before installing or using the appliance for the first time.
- Keep these operating instructions in a safe place and pass them on to any future user.
- Do not use the appliance for other than intended use.

The safety messages will inform you of potential hazards, on how to avoid the risk of injury and what can occur if the instructions are not followed.

IMPORTANT: Observe all codes and ordinances in force.

WARNING: For your safety, the instructions contained in this manual must be followed to minimize the risk of fire or explosion and to prevent property damage, personal injury or death.

Do not store or use gasoline or other flammable vapors, liquids or materials near this or any other appliance.



NOTE: This appliance is NOT designed for installation in manufactured (mobile) homes or in recreational vehicles (RVs).

DO NOT install this appliance outdoors.

IMPORTANT SAFEGUARDS



WARNING



To reduce the risk of fire, electrical shock, personal injury, or damage when using the appliance, follow basic safety precautions, including the following:

Basic safety precautions should always be followed when using electrical appliances.

- Do not touch hot surfaces. Use handles or knobs.
- To protect against electric shock do not immerse the appliance, power cord or plug in water or any other liquid.
- Close supervision is necessary when any appliance is used by or near children.
- Allow to cool before putting on or taking off parts, and before cleaning the appliance.
- Do not operate any appliance with a damaged cord or plug or after the appliance malfunctions, or has been damaged in any manner. Return appliance to the nearest authorized service facility for examination, repair or adjustment.
- The use of accessory attachments not recommended by the appliance manufacturer may cause injuries.
- Do not let cord hang over edge of table or counter, or touch hot surfaces.
- Do not place on or near a hot gas or electric burner, or in a heated oven.
- Extreme caution must be used when moving an appliance containing hot oil or other hot liquids.

WARNING





IMPORTANT SAFEGUARDS

1 Instructions

This user manual is an integral part of the appliance and must therefore be kept in its entirety and be available to the user throughout the entire life of the appliance.

1.1 Intended use



- Do not use appliance for other than intended use.
- This appliance is intended to be used in household and similar applications such as:
 - staff kitchen areas in shops, offices and other working environments;
 - farm houses;
 - by clients in hotels, motels and other residential type environments;
 - bed and breakfast type environment.

Failure to observe the safety instructions and to read the instructions for the multiuse grill may result in improper use of the appliance and may cause personal injury.

- Do not use the appliance for purposes other than those for which it was designed. Improper use may result in injury.
- The appliance is not designed for use with external timers or remote control systems.



WARNING: Do not install / use the appliance outdoors. Use the appliance indoors, protected from the weather.

1.2 General safety instructions

Follow all safety instructions in order to use the appliance safely:

- If the supply cord is damaged, it must be replaced by the manufacturer, its service agent or similarly qualified persons in order to avoid a hazard.
- The appliance and its accessible parts become very hot during use. Small children should be kept away from the appliance. Do not touch the heating elements while the appliance is in use.
- Protect your hands by wearing oven mitts when handling food inside the grill.
- Never attempt to extinguish a fire or flames with water: Turn off the appliance and smother the flames with a fire blanket or other appropriate cover.

IMPORTANT SAFEGUARDS



- This appliance is not intended for use by persons (including children) with reduced physical, sensory or mental capabilities, or lack of experience and knowledge, unless they have been given supervision or instruction concerning use of the appliance by a person responsible for their safety. Children should be supervised to ensure that they do not play with the appliance.
- Keep children under the age of 8 away from the appliance and power cord unless they are supervised at all times.
- Do not allow unsupervised children to clean or maintain the appliance.
- Always monitor the cooking process. A short cooking process must be constantly monitored.
- Never leave the appliance unattended during cooking operations where fats or oils may be released, as these may heat up and catch fire.
- Be very careful.
- Do not pour water directly onto hot plates.
- The appliance and its parts become very hot during use. Do not touch the heating elements while the appliance is in use.
- Do not move the appliance while it is in use.
- Turn off the appliance immediately after use.
- Allow the appliance to cool down after use. Do not touch the internal plates or heating elements as they can be very hot. Risk of burning or scalding!
- Do not put the appliance away until completely cool.
- Do not use or store flammable materials near the appliance.
- Do not use aerosols near this appliance while it is in use.
- Do not modify this appliance.
- Do not attempt to repair this appliance yourself or without the assistance of a qualified technician.
- Do not pull on the cord to unplug the appliance.
- Use only extension cords that comply with applicable safety regulations, are in good condition and have sufficient cross-sectional area.



IMPORTANT SAFEGUARDS

1.3 Caution when using this appliance

- Do not sit on the appliance.
- Do not use cleaning products containing chlorine, ammonia or bleach on parts with metallic surface finishes (e.g. anodized, nickel-plated or chrome-plated).
- Do not use steam to clean the appliance.
- Do not use sprays near the appliance.
- Do not block ventilation openings and heat dissipation slots.
- Fire hazard: do not leave anything inside the appliance.
- Do not use the appliance to heat rooms for any reason.
- Do not use plastic cookware or containers when cooking food.
- Do not cook food wrapped in plastic film, aluminum or tin foil.
- Do not use the handle to lift or move the appliance.
- Make sure nothing is stuck in the seats provided for the plates.
- Use the appliance on a flat, stable surface.
- Avoid spilling liquids on the power plug and base.
- Disconnect the power supply before working on the appliance.

1.4 Connecting the appliance

Make sure that the power supply voltage and frequency match those specified on the data plate on the bottom of the appliance.

If the plug of the appliance is not compatible with the power outlet, contact an authorized service center for replacement.

- Do not allow children to play with the appliance.
- Keep the appliance and power cord out of reach of children.
- Always unplug the appliance when leaving it unattended and before assembling, disassembling or cleaning.
- Always turn off and unplug the appliance before changing accessories or approaching moving parts while the appliance is in use.

SAVE THESE INSTRUCTIONS



1.5 Manufacturer liability

The manufacturer accepts no liability for damage to persons or property caused by:

- Use of the appliance other than for its intended purpose
- Failure to read the user manual
- Tampering with any part of the appliance
- Use of non-original spare parts
- Failure to follow the safety instructions



Please keep this manual in a safe place. If the appliance is passed on to others, they should also receive this booklet.

These instructions can be downloaded from the Smeg website “www.smeg.com”.

1.6 Disposal

Electrical appliances must not be disposed of together with household waste.



Products marked with this symbol are subject to European Directive 2012/19/EU.

- All waste electrical and electronic appliances must be disposed of separately from household waste and taken to an authorized waste disposal facility. Correct disposal of this used appliance will help protect the environment and human health. For more information on how to dispose of used appliances, please contact your local authority waste disposal department or the store where you purchased the appliance.



Description

2 Appliance description (Fig. A)

- 1) Control panel and display
- 2) Upper plate housing
- 3) Lower plate housing
- 4) Handle
- 5) Positioning slider
- 6) Hinge release button
- 7) Drip tray
- 8) Plate release buttons
- 9) Double-sided spatula
- 10) Dosing cup
- 11) Grill and griddle plate set
- 12) Waffle plate set

2.1 Before first use



Risk of burns

High appliance temperature

- Failure to follow these instructions may result in fire, burns, or scalds.



The grill is supplied in "LOCK" mode. Unlock it before use.

- Remove any protective film from the outside or inside of the appliance, including accessories.
- Remove all labels (except for the technical data plate) from the accessories and shelves.
- Remove and wash all accessories (see section "4 Cleaning and maintenance").



Check that all the parts are intact before use.

2.2 Description of parts (Fig. A)

Positioning slider (5)

Release mechanism for adjusting the height of the upper plate.

Hinge release button (6)

Hinge release button for placing the product in the barbecue configuration.

Drip tray (7)

Removable tray to catch drips and grease when cooking on the grill.

Plate release buttons (8)

Buttons to press to remove the plates.

2.3 Description of accessories (Fig. A)

Double-sided spatula (9)

Tool for scraping off food.

Dosing cup (10)

Cup for measuring the waffle batter.

Grill and griddle plate set (11)

Set consisting of a grill plate (11a) and a griddle plate (11b).

Waffle plate set (12)

Set of 2 waffle plates.



The accessories intended to come into contact with food are made of materials that comply with current legislation.



2.4 Description of controls (Fig. B)



Navigation knob (14)

Allows you to select one or both plates, as well as the timer icon, through the different menus on the user interface.



START/ STOP button (15)

Allows you to start (short press) or stop (long press) the cooking process. The corresponding LED lights up with a steady light when cooking has started and goes out when the cooking cycle has finished.



Parameter navigation knob (16)

Allows you to set the time and temperature values shown on the display.



SEAR/ MENU button (17)

In manual mode, it gives access to the three preset programs (short press). In manual mode, press and hold to access the user settings menu. During preheating and cooking, it activates the SEAR function (long press). The corresponding LED lights up when the SEAR function is active.

Display (18)

The display shows the functions, parameters and values of the cooking settings.

2.5 Display description (Fig. C)

Display icons

| | Icon | Meaning |
|---|---------------|-----------------------|
| 1 | | Upper plate off |
| 2 | | Upper plate on |
| 3 | | Lower plate off |
| 4 | | Lower plate on |
| 5 | | Back |
| 6 | | Cooking timer |
| 7 | PANINI | Panini cooking preset |
| 8 | WAFFLE | Waffle cooking preset |
| 9 | BURGER | Burger cooking preset |

Temperature (10)

Displays the cooking temperature of the upper plate (in °C or °F).

Temperature (11)

Displays the cooking temperature of the lower plate (in °C or °F).

Timer (12)

Displays the cooking time set on the timer.



Use

3 Use

3.1 First use

- Heat the grill with empty plates at maximum temperature to remove any manufacturing residue.
- When used for the first time, the appliance may emit an unpleasant odor during heating due to manufacturing residue on some components. This odor usually disappears after the appliance has been heated for the first time.

Using the accessories



Caution

Do not use the appliance without the cooking plates.



Clean the supplied plates and accessories (including the measuring cup and spatula) before first use to remove any manufacturing residue.

The plates are interchangeable and they have integrated heating elements that optimize heat transfer.

Cooking modes (Fig. D)



To use the grill, you must set it to the required cooking mode.

Contact mode (1)

- Contact mode is ideal for cooking hamburgers or grilling vegetables. It is perfect for quickly preparing food.
- The upper plate, once released from the handle, adjusts to the thickness and shape of the food (floating hinge).

Oven mode (2)

- Oven mode is ideal for cooking delicate foods such as fish or meat fillets, or foods that should not be pressed during cooking. It can also be used to heat food.
- The upper plate remains raised compared to the lower plate and can be adjusted to 5 different heights depending on the thickness of the food. This allows the upper plate to just touch the food without crushing it.

BBQ mode (3)

- Allows you to cook different foods without mixing them.
- The open position doubles the cooking surface of the grill.



3.2 Using the grill

Height adjustment (Fig. E)

Lift the handle to move the positioning slider and adjust the height.

Releasing the upper housing from the handle (Fig. F)

The upper housing is attached to the handle. To release it, tilt it down by hand so that it lowers by gravity and is parallel to the lower plate.

Releasing the handle for barbecue mode (Fig. G)

Press the PRESS button on the side to open the grill 180°, guiding the upper plate as it opens.

Handle lock (Fig. I)

After using the appliance, set the positioning slider to "LOCK" to prevent opening.

Releasing the plates (Fig. L)



Caution

Do not remove or replace the plates until the appliance is completely cool.

Lay the appliance flat. Press the release buttons on the housings to remove the plates.

3.3 Preheating



Cooking always begins with a preheating phase to allow the appliance to reach the set cooking temperature.

During preheating, the display shows **PREH** alternating with the set temperature until the preheating is finished.

For example, if the temperature is set at 450°F, the display will alternate between 450°F and **PREH** for both plates (upper and lower, if set).

When preheating is complete, the grill will beep, the PREH indicator will disappear and the timer will start blinking, if it is set. Place your food on the plates and press START to begin the timer countdown.



Carry out the Preheating phase with the grill in contact mode to reduce heat dispersion.



Use

3.4 Manual mode

Setting the cooking temperature

To start using the grill, you can set a different temperature for each plate.

The values can be set between 150°F and 450°F.

- 1) Turn the left knob to select the symbol corresponding to the parameter you wish to modify on the upper and/or lower plate.
- 2) Turn the right knob to increase or decrease the temperature.
- 3) Press the START/STOP button to begin cooking.

If either plate is off or no temperature has been set, the plate icon will disappear and **OFF** will be displayed.

Setting the timer

The timer can also be set:

- 1) Turn the left knob to select the timer icon.
- 2) Turn the right knob to set the time in minutes and seconds.
- 3) Press the START/STOP button to confirm.



You can increase or decrease the set time at any time during cooking.



At the end of the preheating phase **P-EH**, if the timer was set before cooking, the left knob and the timer on the display flash to indicate that double confirmation is required in order to start the countdown.



If no timer is selected, the product will turn off automatically after 60 minutes.

3.5 Preset mode



To enter preset mode, make sure you are in manual mode and press and release the SEAR/MENU button.

Selecting the preset mode

To start using the grill, you can select a cooking preset.

Each preset consists of a fixed upper and lower plate temperature.

Before starting the function:

- 1) Turn the left knob to select the icon corresponding to the required preset mode.
- 2) Press the START/STOP button to start the function.



| | Preset | Upper plate temperature | Lower plate temperature |
|---------|---------------|-------------------------|-------------------------|
| Panini | PANINI | 400°F | 450°F |
| Waffle* | WAFFLE | 350°F | 350°F |
| Burger | BURGER | 450°F | 450°F |

* For this particular preset, you must use the 2 special waffle plates provided.

Customizing existing presets

You can modify the parameters of existing presets and create custom settings for future use.

- 1) Select the preset you wish to edit.
- 2) Press and hold the SEAR/MENU button to enter edit mode.

- 3) Turn the left knob to navigate through the parameters and rotate the right knob to set the values.
- 4) Press and hold the SEAR/MENU button to save the new settings.



To restore the default values, make sure you are in manual mode and press and hold the START/STOP button for 10 seconds.



Use

3.6 SEAR function

The SEAR mode is designed to seal food, especially meat, by heating the plates to the maximum temperature allowed by the heating elements for a limited period of time.

To activate the SEAR function, press and hold the SEAR/MENU button during preheating or cooking.



- This function is only available during preheating or cooking when a temperature of at least 400°F is set.
- This function can be used once every 30 minutes.
- It is recommended that you activate this function during the preheating phase.

During the preheating phase, the display alternates between **SEAR** and **PREH.**

When the plates reach the maximum allowed temperature, the appliance will beep, and **SEAR** will appear steadily on the display. The countdown for the function will then start.

Once the function ends, the temperature of each plate is then automatically reduces to the set temperature.

3.7 Settings Menu

To access the User Settings menu in manual mode:

- 1) Press and hold the SEAR/MENU button.
- 2) Turn the left knob to scroll through the menu items.
- 3) Turn the right knob to set the required value and press the SEAR/MENU button to confirm.



Setting the units of measurement

Sets the unit of temperature measurement in Celsius (°C) or Fahrenheit (°F).













Sound

Enables (ON) or disables (OFF) the sounds emitted by the grill.















3.8 Cooking table

Cooking times provided are approximate and may vary based on the quality, thickness, and nature of the food.

| Type | Cut | Cooking level | Quantity | Opening Method | °F |  (min) | SEAR | Tips |
|--------------|----------------|-----------------|----------|---|-----|---|------|---|
| Meat Beef | Fillet | Rare (50°) | 3 / 4 |  STEP 2 | 450 | 5 | ✓ | Thickness: 3 cm Turn half way through cooking |
| | | Medium (60°) | 3 / 4 |  STEP 2 | 450 | 7 | ✓ | Thickness: 3 cm Turn half way through cooking |
| | | Well done (70°) | 3 / 4 |  STEP 2 | 450 | 10 | ✓ | Thickness: 3 cm Turn half way through cooking |
| | Hamburger | Rare | 4 |  | 450 | 1 | X | ~ 140 g each |
| | | Medium | 4 |  | - | - | X | BURGER You can use the HAMBURGER preset |
| | | Well done | 4 |  | 450 | 4 | X | ~ 140 g each |
| | New York Steak | Rare (50°) | 2 / 3 |  STEP 1 | 450 | 3 | ✓ | Thickness: 2 cm Turn half way through cooking |
| | | Medium (60°) | 2 / 3 |  STEP 1 | 450 | 5 | ✓ | Thickness: 2 cm Turn half way through cooking |
| | | Well done (70°) | 2 / 3 |  STEP 1 | 450 | 7 | ✓ | Thickness: 2 cm Turn half way through cooking |

















Use

| Type | Cut | Cooking level | Quantity | Opening Method | °F |  (min) | SEAR | Tips | |
|------|--------------------|--------------------------|-----------|-----------------------|---|---|------|------|---|
| Meat | Pork | Bacon | Well done | 6 |  | 450 | 5 | X | - |
| | | Sausages | Well done | 6 |  STEP 2 | 400 | 18 | X | 140 g sausage, approx. 3cm ø |
| | | Sausages | Well done | 12 |  | 450 | 30 | X | 140 g sausage, approx. 3cm ø |
| | | Chop | Well done | 2 / 3 |  STEP 1 | 375 | 5 | ✓ | Thickness: 3 cm |
| | | Pork neck | Well done | 2 / 3 |  | 400 | 4 | ✓ | Thickness: 2.5 cm |
| | | Wurstel | Well done | 9 - 12 |  | 400 | 8 | X | 80 g each |
| | Chicken and turkey | Butterfly chicken breast | Well done | 4 from a 325 g breast |  STEP 1 | 450 | 5 | X | Upper plate just touching the food |
| | | Fillets | Well done | 10 - 14 |  STEP 1 | 450 | 5 | X | Upper plate just touching the food |
| | | Chicken legs | Well done | Up to 10 legs |  STEP 3 | 400 | 40 | X | Upper plate just touching the food, turn the product half way through cooking |
| | | Chicken wings | Well done | Up to 20 wings |  STEP 2 | 400 | 30 | X | Upper plate just touching the food, turn the product half way through cooking |
| | | Deviled chicken | Well done | 1 - 2 |  STEP 1 | 450 | 20 | X | 600 g each Turn halfway through cooking |
| | | Chicken skewers | Well done | 4 - 10 |  STEP 1 | 450 | 14 | X | Turn several times during cooking |

Use

















EN





| Type | Quantity | Opening Method | °F |  (min) | SEAR | Tips | |
|------------|-------------------------------|---------------------------------------|--|---|------|------|---|
| Fish | Salmon fillet | 2 |  STEP 2 | 450 | 5 | X | Upper plate in contact with food |
| | Fish cutlets | 2 / 3 |  STEP 1 | 400 | 8 | X | Turn half way through cooking |
| | Octopus | Precooked |  | 450 | 8 | X | Turn half way through cooking |
| | Prawns (shelled tails) | 20 |  STEP 1 | 450 | 3 | X | The upper plate must not touch the product, if desired, turn half way through cooking |
| | Scallops | 24 - 18 |   | 450 | 6 | X | - |
| | Sea bream/ sea bass | 2 whole |  STEP 3 | 400 | 15 | X | 300/400 g each Turn half way through cooking Upper plate in contact with the food |
| | Sea bream/ sea bass fillet | 4 fillets |  STEP 1 | 450 | 3 | X | 80/100 g each Upper plate just touching the food |
| | Tuna fillet | 4 |  STEP 2 | 450 | 3 | X | - |
| | Fish skewers | 4 - 10 |  | 450 | 12 | X | Turn several times during cooking |
| Vegetables | Zucchini | 10 - 14 slices |  | 400 | 8 | X | Thickness: 1 cm Turn half way through cooking |
| | Peppers | 10 slices |  | 400 | 10 | X | Turn half way through cooking |
| | Eggplant | 8 - 12 slices |  | 400 | 8 | X | Thickness: 1 cm Turn half way through cooking |
| | Mushrooms | Variable weight depending on the type |  | 450 | 13 | X | Turn half way through cooking |



Use

| Type | Quantity | Opening Method | °F |  (min) | SEAR | Tips | |
|----------------|-----------------------|----------------|---|---|------|------|--|
| Vegetables | Sliced potatoes | 12 - 16 slices |  | 325 | 18 | X | Thickness: 1 cm Turn half way through cooking |
| | Whole sliced onion | 12 - 16 slices |  | 400 | 10 | X | Thickness: 1 cm Turn half way through cooking |
| | Sliced onion | 1 - 3 onions |  | 400 | 8 | X | Stir regularly during cooking |
| | Vegetarian hamburger | 4 - 6 |  | 450 | 5 | X | 100 g each |
| Bread and eggs | French toast | 2 - 3 |  | 400 | 8 | X | - |
| | Stuffed sandwich | 2 |  | - | - | X | PANINI You can use the PANINI preset |
| | Focaccia | 2 |  | - | - | X | PANINI You can use the PANINI preset |
| | Fresh bread | 2 - 4 slices |  STEP 1 | - | - | X | PANINI You can use the PANINI preset |
| | Bullseye eggs | 1 - 4 |  | 450 | 2 | X | - |
| Dessert | Caramelized pineapple | 3 / 4 |  | 450 | 6 | ✓ | Turn half way through cooking |
| | Pineapple | 3 / 4 |  | 450 | 8 | ✓ | Turn half way through cooking |
| | Waffle | 4 |  | - | - | X | WAFFLE You can use the WAFFLE preset |
| | Cocoa waffle | 4 |  | 180 | 8 | X | Use the waffle plates provided |
| | Protein waffles | 4 |  | 180 | 7 | X | Use the waffle plates provided |



| Type | Quantity | Opening Method | °F |  (min) | SEAR | Tips |
|---------|------------------|---|-----|---|------|------|
| Dessert | Pancakes |  | 400 | 3 | X | - |
| | Banana pancakes |  | 400 | 8 | X | - |
| | Protein pancakes |  | 400 | 7 | X | - |

WAFFLES

Ingredients for about 12 waffles:

- 300 g flour
- 300 ml whole milk
- 2 eggs
- 1 vanilla pod
- 75 g sugar
- 100 g butter
- 2 pinches of salt
- 10 g of yeast

Procedure:

- 1) Melt the butter.
- 2) Place all the ingredients in a large jug.
- 3) With the help of an immersion blender, mix well until the mixture is smooth.
- 4) Let it sit for at least 30 minutes.
- 5) With the help of the measuring cup (1 measuring cup = 2 waffles), pour the mixture onto the plate and cook for the time shown on the cooking timetable.

COCOA WAFFLES

Ingredients for about 8 waffles:

- 180 g 00 flour
- 100 g sugar
- 20 g cocoa powder
- 12 g baking powder
- 3 g salt
- 240 g whole milk
- 2 eggs
- 60 g butter

Procedure:

- 1) Melt the butter.
- 2) Place all the ingredients in a large jug.
- 3) With the help of an immersion blender, mix well until the mixture is smooth.
- 4) Let it sit for at least 30 minutes.
- 5) With the help of the measuring cup, pour the mixture onto the plate and cook for the time shown on the cooking timetable.



Use

PANCAKES

Ingredients for about 12 pancakes:

- 290 g 00 flour
- 60 g sugar
- 16 g baking powder
- A pinch of baking soda
- 2 pinches of salt
- 440 ml milk
- 60 g melted butter
- 1 medium egg
- 1/2 vanilla pod

Procedure:

- 1) Melt the butter.
- 2) Place all the ingredients in a large jug.
- 3) With the help of an immersion blender, mix well until the mixture is smooth.
- 4) Let it sit for at least 30 minutes.
- 5) Pour the mixture onto the plate and cook for the time shown on the cooking timetable.

PROTEIN PANCAKES

Ingredients for about 12 pancakes:

- 60 g 00 flour
- 2 large eggs
- 1 tsp vanilla extract
- 70 g sugar
- 120 g natural Greek yogurt
- 40 g whey protein powder (neutral or vanilla flavor)
- 16 g baking powder
- 1 tsp baking soda

Procedure:

- 1) Place all the ingredients in a large jug.
- 2) With the help of an immersion blender, mix well until the mixture is smooth.
- 3) Let it sit for at least 30 minutes.
- 4) Pour the mixture onto the plate and cook for the time shown on the cooking timetable.



4 Cleaning and maintenance

This manual contains cleaning and maintenance instructions and recommendations from the manufacturer to the customer. All other work should be carried out by an authorized service center.



Caution

- Do not use steam to clean the appliance.
- Do not use cleaning products containing chlorine, ammonia, bleach or alcohol on steel parts or parts with metallic surface finishes.
- Do not use abrasive or strong detergents (e.g. powder products, stain removers or metal scourers).
- Do not use rough or abrasive materials or sharp metal scrapers.
- Clean components and accessories regularly after use.



WARNING: Always unplug the appliance and allow it to cool before cleaning. To keep the surfaces in good condition, clean them regularly after use.

Normal daily cleaning

Always use specific products that do not contain abrasives or chlorine-based acids.

Pour the product onto a damp cloth and wipe the surface, rinse thoroughly and dry with a soft cloth or microfiber cloth.

Food stains or residue

Do not use steel sponges or sharp scrapers, as they will damage the surface.



We recommend that you use the spatula to remove any residues.

Use ordinary non-abrasive products and a wooden or plastic tool if necessary. Rinse thoroughly and dry with a soft cloth or a microfiber cloth.

Do not allow residues of sugary foods (such as jam) to set in the appliance. If left too long, they will harden and can damage the enamel lining of the appliance.

Cleaning the accessories

The cooking plates are dishwasher-safe, but repeated use may cause slight discoloration. This discoloration is purely cosmetic and does not affect performance. It is recommended to clean the exterior of the plates using a soft sponge or cloth moistened with water and a mild detergent. Avoid using metal tools to clean as they may damage the surfaces.

It is recommended to wash the spatula and measuring cup by hand.

Removing the drip tray (Fig. H)



Check the drip tray frequently during cooking.

The tray is removable for easy cleaning and it is recommended to wash it by hand.

Dispose of collected grease properly.



Cleaning and maintenance

| Problem | Possible cause | Solution |
|---|--|---|
| The multipurpose grill does not turn on. | The plug is not properly inserted into the outlet. | Make sure the plug is properly inserted into the outlet. |
| | The power cord is defective. | Contact your local service center. |
| | No power. | Make sure the power supply is working properly. If the problem persists, contact a qualified electrician. |
| The display does not turn on. | The plug is not properly inserted into the outlet. | Make sure the plug is properly inserted into the outlet. |
| | Possible electronic board failure. | Contact your local service center. |
| Cooking does not start | Failure to confirm after preheating | Make sure that you confirm the cooking phase when the preheating stage ends (see section...). |
| | The heating element may be faulty. | Contact your local technical support centre. |
| Cooking has started but the grill does not heat up. | The heating element may be defective. | Contact your local service center. |

What to do if...

| Problem | Possible cause | Solution |
|---|--|--|
| There is a burning smell when the multiuse grill is in operation. | There may be a burning smell the first time you use the appliance. Possible food residue inside the appliance in contact with the heating elements. | Make sure you have followed the instructions when using the appliance for the first time. Be sure to follow the cleaning and maintenance instructions (see section "4 Cleaning and maintenance"). |
| The SEAR function is not activated | The selected temperature is lower than required. The time elapsed since the last activation is not long enough. | Make sure you have set a temperature equal to or higher than 400°F to activate the function (see section "3.6 SEAR function"). Make sure that at least half an hour has elapsed since the last use of the function (see section "3.6 SEAR function"). |
| The SEAR function deactivates after some time. | It's normal. | The SEAR function is designed to remain active for the time necessary to ensure an excellent seal. It remains active for 30 seconds, then deactivates automatically and the temperature will return to the previously set one. |

What to do if...

| Problem | Possible cause | Solution |
|---|--|--|
| The “Waffle” preset does not appear on the display | The product is in BBQ mode. | Make sure the product is closed when you want to select the preset. |
| The countdown does not start | No confirmation after preheating when a timer is set to manual mode. | Make sure you have confirmed the countdown after preheating (see section “Setting the timer”). |
| The display shows one of the following error codes: Err 1 Err 2 Err 3 Err 4 | - | Contact your local service center. |



If the problem persists, or there are other faults, contact your local service center.

The manufacturer reserves the right to make any changes deemed necessary for the improvement of its products without prior notice. The illustrations and descriptions contained in this manual are therefore not binding and are merely indicative.

Le fabricant se réserve la faculté d'apporter, sans préavis, toutes les modifications qu'il jugera utiles pour l'amélioration de ses produits. Les illustrations et les descriptions figurant dans ce manuel ne sont pas contraignantes et n'ont qu'une valeur indicative.

El fabricante se reserva el derecho a aportar sin aviso previo todas las modificaciones que considere útiles para la mejora de sus propios productos. Las ilustraciones y las descripciones contenidas en este manual no son vinculantes y tienen solo valor indicativo.