

# ASSEMBLY INSTRUCTIONS

**CROWNMARK  
B4852WH-RACK  
RACK**

(BOX 1)  
PART LIST

No	ITEM	Qty
A	Mirror	1 pc
B	Rack	7 pcs

(BOX 1)  
HARDWARE LIST

No	ITEM	Qty
1	JCBC M6 x 50mm	14 pcs
2	Wood Dowel 8 x 30mm	14 pcs
3	Wall Plug	2 pcs
4	Barrel Nut M6 x 15mm	14 pcs
5	Flat Head Chipboard Screw M4 x 45mm	2 pcs
6	ALLEN KEY m4x65mm Blk	1 pc
7	Sticker	10 pcs

REMARK:  
THE HARDWARE IS LOCATED IN THE PACKING ITEM.

STEP 1: Insert wood dowel(2) at Rack as shown. Attach rack (B) on mirror (A) groove and Insert Barrel Nut(4) from top and bottom at hole as shown. Secure with JCBC screw(1), Then tighten with Allenkey (6) as shown.

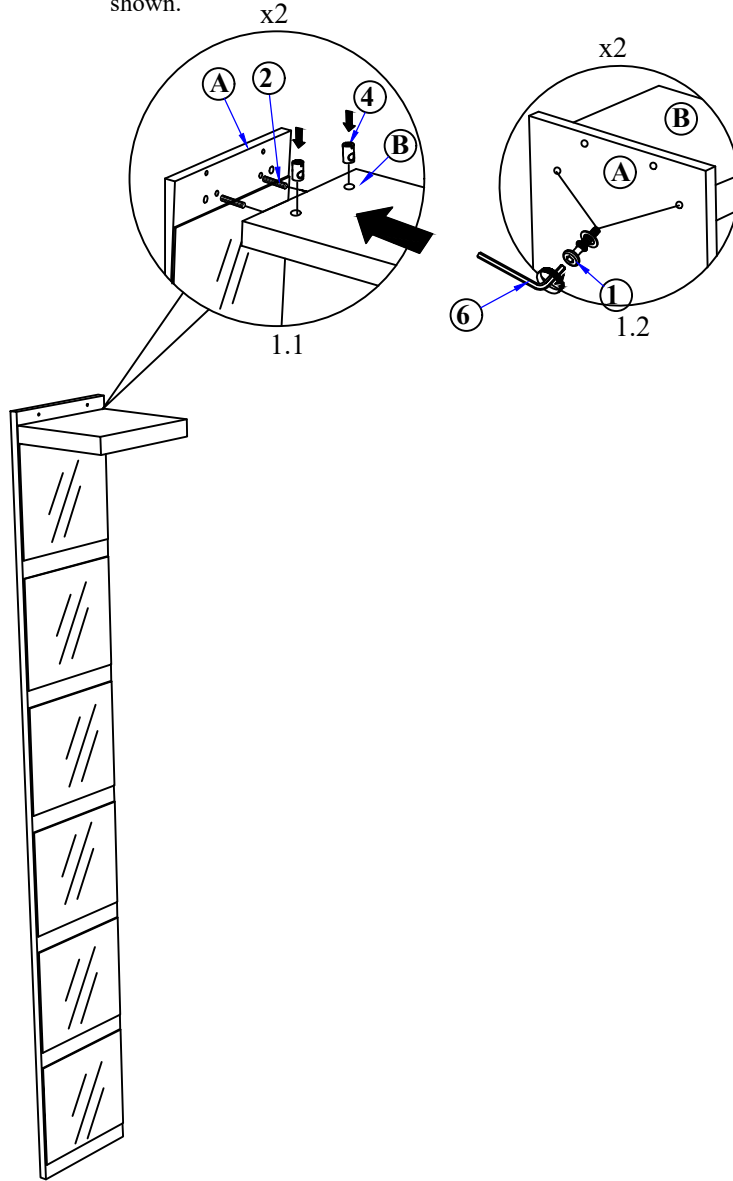

STEP 2: Turn Rack and Mirror(A) from view actual to upside down position as shown. Insert wood dowel(2) at Rack as shown. Attach rack (B) on mirror (A) groove and Insert Barrel Nut(4) from top and bottom at hole as shown. Secure with JCBC screw(1), Then tighten with Allenkey (6) as shown.

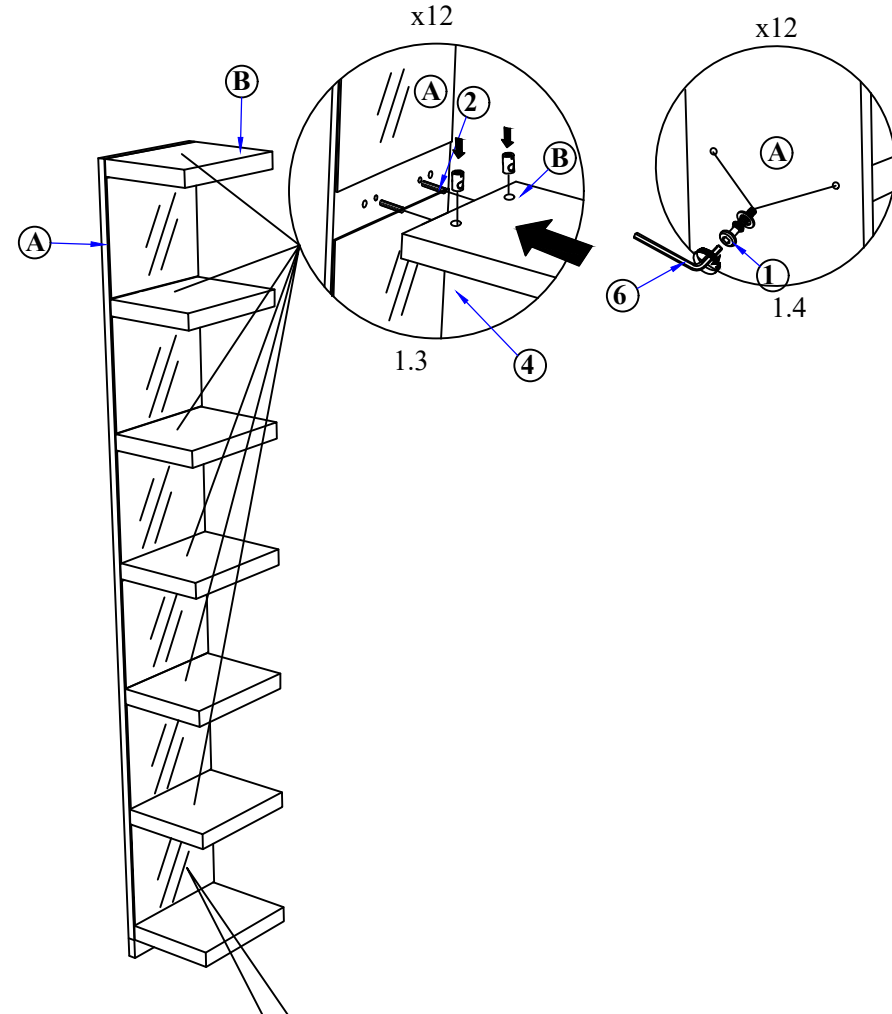

Remark : Turn the Rack and Mirror to upside down position as shown.

# ASSEMBLY INSTRUCTIONS

**STEP 3:** Please paste sticker(7) before turn the Rack and Mirror(A) from upside down to actual position.

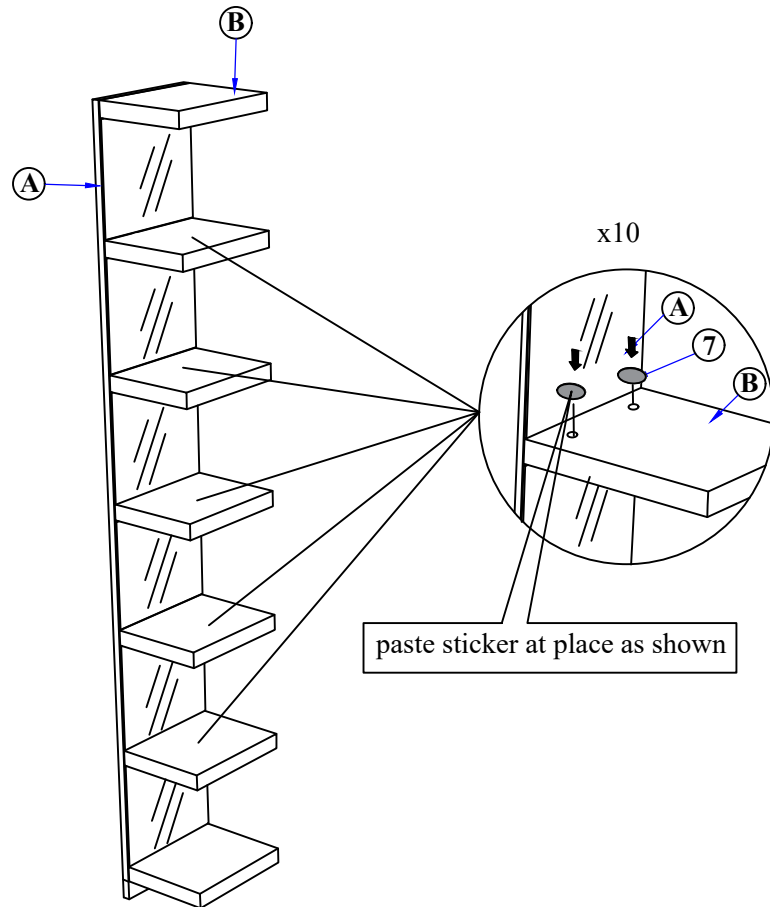

**STEP 4:** Please align and touch t mirror(A) at the wall. Please marking and drill hole for Insert Wall plug(3) to the wall. Then secure Tall Mirror (A) with flat head chipboard screw(5) and tighten with screw driver (not included )as shown.

**WARNING! : Need two Peoples to place the Mirror.**

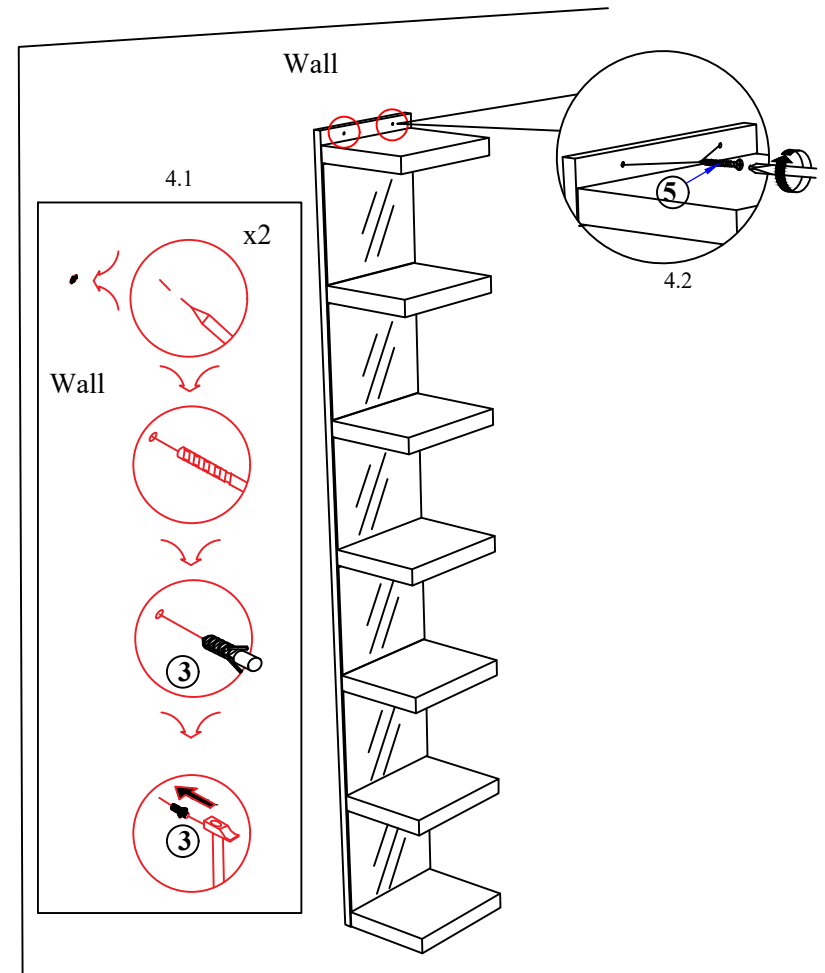

NOTE : Periodically check to ensure that all connectors (bolts, screws, etc.) are tight.